

# **A REVIEW OF ALTERNATIVES FOR MANAGING ARCTIC HYDROGRAPHIC DATA**

**ANGUS HAMILTON  
SALEM MASRY**

**March 1980**



**TECHNICAL REPORT  
NO. 81**

## PREFACE

In order to make our extensive series of technical reports more readily available, we have scanned the old master copies and produced electronic versions in Portable Document Format. The quality of the images varies depending on the quality of the originals. The images have not been converted to searchable text.

A Review of Alternatives for  
Managing Arctic Hydrographic Data

Prepared by

Angus C. Hamilton

and

Salem E. Masry

Department of Surveying Engineering

University of New Brunswick

for

The Canadian Hydrographic Service

Department of Fisheries and Oceans

under

Department of Supply and Services

Contract No 0EZ79-06062

March 1980

## Preface and Acknowledgements

This study was undertaken by Professors Hamilton and Masry of the Department of Surveying Engineering at the University of New Brunswick at the request of the Department of Supply and Services acting on behalf of of the Canadian Hydrography Service, Department of Oceans and Fisheries.

The task was defined in the request as follows: "To conduct research into the management, i.e. storage, retrieval and maintenance of the CHS Arctic Hydrographic Data Base".

Mr. John Warren of the Geoscience Mapping Section of the Canadian Hydrographic Service was designated as project officer and Mr. Neil Anderson, Chief of the Policy and Planning Section provided general direction and guidance on the project.

The whole-hearted cooperation of the staff at CHS Headquarters in Ottawa and at Eastern Region in Bedford is gratefully acknowledged. No attempt will be made to list all those with whom discussions -- some lengthy, some brief -- were held, however we would be remiss if we did not acknowledge John Warren, and John O'Shea at Headquarters and Ross Tracey and G.E. Bowman at Bedford who compiled data especially for us.

We are particularly grateful to Mr. Ken McConnell, Chief of the Standards and Information Section of the Gravity Division, Earth Physics Branch for providing us with full details on the operation of the National Gravity Data Base.

In addition, one of the authors (Hamilton) gratefully acknowledges the co-operation of Lt. Commander Gregory Bass of the Marine Data Systems Project, U.S. National Ocean Survey, by arranging for a visit to the Project office and a meeting with several of those involved in the testing and evaluation of their Automated Information System.



A.C. Hamilton

S.E. Masry

March 31, 1980

A REVIEW OF ALTERNATIVES FOR MANAGING ARCTIC  
HYDROGRAPHIC DATA

---

	<u>Page No.</u>
1. INTRODUCTION AND SUMMARY	1.
2. THE NATIONAL GRAVITY DATA SYSTEM	5.
2.1 Background and Rationale	5.
2.2 The Components of the Data System	5.
2.2.1 The Structure of the Anomaly Data Base	8.
2.2.2 Project Review	10.
2.2.3 The Main Input Sub-Systems	11.
2.2.4 Supporting Files	16.
2.2.5 The Network Reduction and Adjustment Sub-System	16.
2.2.6 The Retrieval and Plotting Sub-Systems	19.
2.3 Comments on the Use of System 2000 by R.K. McConnell	19.
3. ARCTIC HYDROGRAPHIC DATA: PURPOSE, QUANTITY AND FLOW	22.
3.1 Purpose	22.
3.2 Sources and Quantities	22.
3.2.1 Current	24.
3.2.2 Projected	29.
3.3 The Flow of Arctic Hydrography Data	29.
4. ALTERNATIVES	32.
4.1 Alternative #1 - A Digitally-Oriented System with Graphic Phases	34.
4.2 Alternative #2 - A Graphically-Oriented System with Digital Phases	35.
4.3 Alternative #3 - The No-System Approach	35.
4.4 Comparison of Alternatives 1 and 2	36.
5. AN IMPLEMENTATION SCENARIO	40.
5.1 Hydrographic Data in Nautical Chart Production	40.
5.2 The People Factor	43.
5.3 Suggested Sequence of Steps for Developing a New Approach to the Management of Arctic Hydrography Data.	44.

	page
APPENDIX A: Arctic Hydrography Data by Type and Year.	45
APPENDIX B: Classification Criteria for Deep Ocean Soundings.	55
APPENDIX C1: National Ocean Survey Automated Information System by William G. Swisher.	64
C2: Brief Comment on the NOS/AIS by A.C. Hamilton.	86
APPENDIX D: Preliminary Agenda and Participation for a Workshop on the Management of Arctic Hydrography Data.	87

#### FIGURES

	<u>page</u>
2.1 The files of the national gravity data system as of Nov. 1979.	6
2.2 The national gravity data system.	7
2.3 The items for each gravity anomaly record in the System 2000 data base.	9
2.4 The static gravity data reduction sub-system.	12
2.5 Format for gravity data input to the static reduction sub-system	13
2.6 Format for altimetry data input to the static gravity reduction sub-system.	14
2.7 Format for input of Decca readings.	15
2.8 Flow chart for the dynamic gravity sub-system.	17
2.9 Flow chart of the retrieval and plotting sub-system.	18
3.1 The statics of hydrographic surveys north of 60°N.	23
3.2 The main stages of the flow chart for Arctic hydrography data.	30
4.1 The principal components of a digitally-oriented Arctic hydrography data system.	33
5.1 Two conceptual models for the management of nautical chart data.	41

#### TABLES

3.1 The number of soundings on file at C.H.S.	24
3.2 C.H.S. Arctic data 1970-1979.	27
3.3 Data from other sources 1970-1979.	28
4.1 Advantages and disadvantages of digitally-oriented and graphically-oriented approach to managing Arctic hydrography data.	37
5.1 The principle themes of a nautical chart and the agencies responsible for the management of the theme data.	40

## A REVIEW OF ALTERNATIVES FOR MANAGING ARCTIC HYDROGRAPHIC DATA

### INTRODUCTION AND SUMMARY

Until recently the challenge to surveyors of all types, be it geodetic, topographic, hydrographic, or land surveyors has been to get out and get data. Very little attention was given to the data already on file because for many regions, particularly in the Arctic, there was very little data on file. Rather suddenly all that has changed. We are fast approaching the situation of most other westernized countries; much of the data needed for the compilation of a map or a chart is already on file -- somewhere. The challenge is to find all the relevant data and to synthesize it.

When the major challenge facing surveyors was to collect data, there was great emphasis on sensors and platforms. Thus Canadians have been leaders in exploiting aerial photography, electronic distance measuring equipment and echo sounders. Along with the emphasis on data collection and on instrumentation a field-oriented culture developed. This is reflected in the new generation of highly qualified, enthusiastic hydrographers at the Canadian Hydrographic Service. The improved instrumentation, the better platforms and the funding fueled by a resource-oriented economy has meant that the rate of collecting data has been increasing almost exponentially. Meanwhile, back in the office, although the electronic computer has been used for the tedious computational aspects of processing data it has not yet been successfully exploited on the overall challenge of managing this enormous volume of data.

Rather suddenly, coincident with the scarcity of funds (for collecting data), survey managers are realizing that the new challenge is in managing and effectively utilizing the data they already have. This problem is particularly acute in cities; for decades subdivision plans have been filed, construction drawings have been put away and great expansions of cities have taken place. Now however, there is considerable emphasis on urban renewal; for this the first and major requirement is to find out what is actually there

both as to property units and as to utilities. This involves extensive searching and synthesizing of records; this has made managers realize that the approach to the management of their data has been deplorable. At the national level, the emphasis has been on new mapping for the 1:50,000 series. However, doing this new mapping has left few resources for map revision. Now it is being realized that the revision of the maps in the areas where changes are taking place is becoming more important than mapping remote areas where there is no activity. For map revision much of the data is already on file; the challenge is to find it, verify it, and redisplay it.

Although this is a relatively new challenge to mapping and charting there are some concepts in related fields that are relevant to the management of hydrographic data:

*The Curtain Principle* is one of these concepts. Anyone who has bought property in Ontario, Quebec or the Maritimes has paid a lawyer to "search" the title. For a fee of several hundred dollars the lawyer, (or his clerk) has gone to the registry office and "searched" in the register of property transactions to ensure that the person purported to be selling the property actually owns it. The search does not stop when the lawyer finds the record showing that the vendor acquired the property; in theory, it continues back through the records to the Crown grant. If you buy a house in any of the western provinces or in Northern Ontario you will pay a lawyer a charge for transferring the title of the house but you will not be paying for a search. This is because in the west a Land Titles system is in effect whereby an official known as the Master of Titles having the status of a judge will issue a certificate stating unconditionally that you are the new owner of the property. No searching of old title documents is necessary; in effect, the old documents can be left undisturbed behind a curtain. This is the essence of the curtain principle.

*The Multi-Purpose Data Base* is another relevant concept. Published maps and charts, in general, are a form of multi-purpose data base. In fact, the reason they are published is so that they can be available to many users. Topographic maps in particular are certainly multi-purpose; they are used for economic planning, for military exercises, for recreational activities, for providing coastline planimetry and topography to hydrographers and for many other purposes. There are, however, at least some users of multi-purpose maps who



the input sub-systems and related files, the data base by itself would rapidly degenerate to an ineffective level.

In Chapter 3 the purpose, quantity and flow of Arctic hydrography data are discussed briefly. North of 60° N the number of soundings on file is estimated at 834 000. Of this, almost 20% has been made available to the C.H.S. by industry and other agencies who had collected it initially for their purposes.

From a brief study of the way in which hydrographic data is handled by the C.H.S. it is suggested that it can best be described as *a graphically-oriented system with digital phases*. By comparison, the gravity system discussed in Chapter 2 can be described as *a digitally-oriented system with graphic phases*.

In Chapter 4 three possible alternative approaches to the management of Arctic hydrography data are identified as:

- (i) A digitally-oriented system with graphic phases.
- (ii) A graphically-oriented system with digital phases.
- (iii) A no-system approach.

The third alternative is mentioned in order to cover the possibility that sensor technology might evolve such that it would be more economical to re-collect data than to maintain a data management system. As such a possibility cannot be foreseen at this time this alternative is rejected.

It is concluded that the time has come to change from a graphically-oriented system with digital phases to a digitally-oriented system with graphic phases. It is implicit that in addition to storing all soundings in digital form utilizing some type of software package such as System 2000 there would be a suite of input sub-systems and associated files similar in many respects to those associated with the Gravity Data System.

In Chapter 5 an implementation scenario is presented. It is pointed out that due to the need for synthesis and judgement in managing foreshore (tidal zone) data it is not reasonable to expect to incorporate it in the digitally-oriented system outlined in Chapter 4. It is suggested that the transition from a graphically-oriented to a digitally-oriented system should proceed theme by theme. Finally as one step for the implementation scenario it is suggested that a workshop on the management of Arctic hydrography data be held.

## 2. THE NATIONAL GRAVITY DATA SYSTEM

The description of the National Gravity Data System which follows has been put together from material supplied by Mr. R.K. McConnell, chief of the Standards and Information Section of the Earth Physics Branch.

### 2.1 Background and Rationale

The following extract from a presentation by McConnell to the Pan American Institute of Geography and History (PAIGH) in September 1976 and published in "Geophysics in the Americas - Session 5" will serve as an introduction to the system:







"The launching of a systematic gravity mapping program in Canada coincided conveniently with the introduction of the first large scale digital computers. Although employed initially as a data reduction tool, the rapid development of computer technology soon led to the use of computers for storage and retrieval of gravity data. The present structure of the National Gravity Data Base and the design of its accompanying data reduction and management software has evolved in response to the requirement of Canadian government, industry and university geophysical research programs for gravity and related data in computer processable or digital map form. In addition the National Gravity Data System has been designed to process and distribute station descriptions and digital information relating to the National Gravity Net which forms the basis of gravity standards in Canada. A further factor influencing the design of the data base has been the requirement to provide to the International Gravimetric Bureau a scientific and technical service for the management of data and station descriptions related to the International Gravity Standardization Net 1971."

### 2.2 The Components of the Data System

In order to compute gravity anomalies two types of data are necessary:

- (i) Gravity measurements and calibration data
- (ii) Associated data: position, elevation, or depth and topographic (digital terrain) data.

Because gravimeters measure relative difference in gravity rather than absolute gravity it is essential to have a network of precisely

FILE	SIZE IN CHARACTERS	FILE MANAGEMENT SOFTWARE
 CONTROL STATION DATA	$2.5 \times 10^6$	S2K
 CONTROL STATION DESCRIPTIONS		
 NETWORK OBSERVATION DATA	$5 \times 10^6$	IN-HOUSE
 INSTRUMENT DATA	$10^5$	IN-HOUSE
 ANOMALY DATA	$4 \times 10^7$	S2K
 TOPOGRAPHIC DATA	$2 \times 10^6$	IN-HOUSE

In addition to these active files there is a large archival file of observation data.

Figure 2.1 The files of the National Gravity Data System as of Nov. 1979.

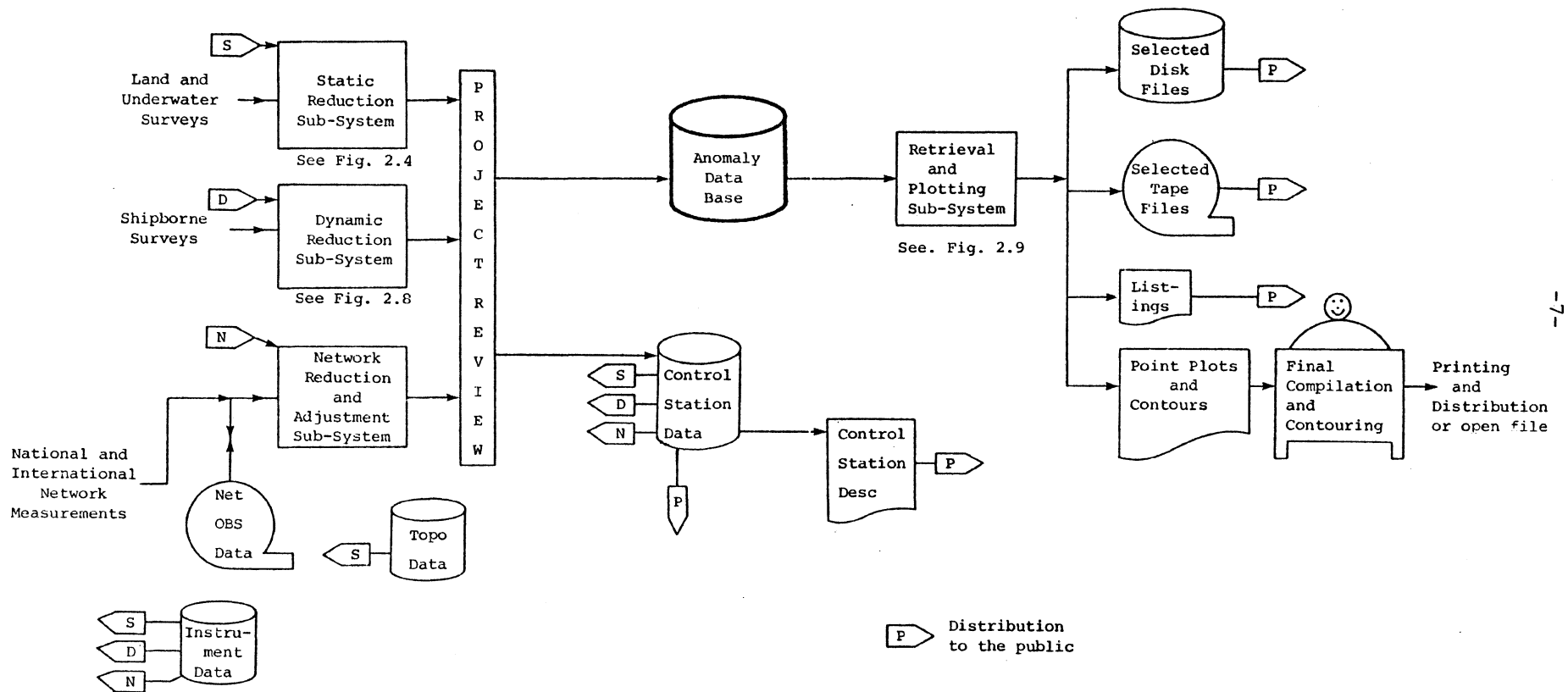

Fig. 2.2 The National Gravity Data System

determined stations to which to tie in at frequent intervals. Thus the need for a gravity control station file and for network observation data. Also because the instruments are not perfectly linear and because they may change slightly from time to time it is necessary to have a file of instrument data.

Position data is needed for plotting the location of the observations and elevation or depth data and topographic data needed for computing the various anomalies. In Figure 2.1 the various files that constitute the National Gravity Data System are illustrated; their approximate size and the type of file management software being used for each file as of the fall of 1979 is also listed.

In Figure 2.2 the major components and the major sub-systems and the linkages between them are shown.

It should be clear that the Anomaly Data Base is the heart of the National Gravity Data System (N.G.D.S.). All of the activities and the files that are used in the reductions systems prior to the project review are for the purpose of ensuring that clean valid data and only clean valid data is put into the anomaly data file. Similarly, the retrieval and plotting systems are simply for the purpose of making effective use of the data that is in the anomaly data base. Each of the major sub-systems will be discussed briefly.

#### 2.2.1 The Structure of the Anomaly Data Base

As indicated in Figure 2.1 the anomaly data is stored on a commercial data base management system known as System 2000 (S2K). A list of the items that make up the data record for each gravity point are shown in Figure 2.3.

It is interesting to note that although this is called an anomaly data base, there are no anomalies as such listed in the contents. This is not an oversight. The anomalies in fact are not stored at all. They are computed from the relevant source data. It should be noted too that for each parameter there is an accuracy factor included in the file; for coordinates, there is a coordinate accuracy factor; for depths, there is a depth accuracy factor; for the adjusted gravity value, an accuracy

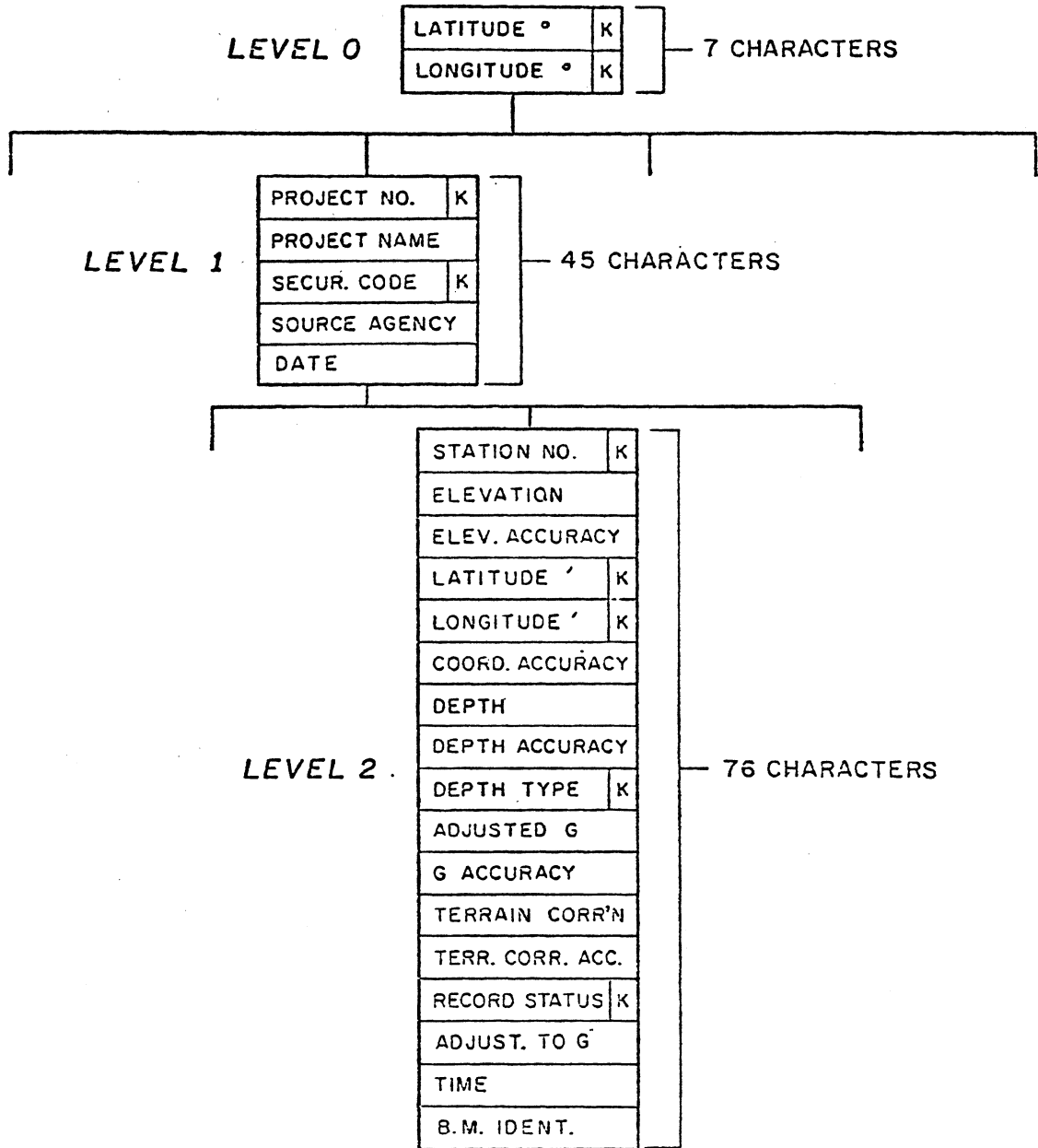

Fig. 2.3 The items for each gravity anomaly record in the SYSTEM 2000 data base.

factor and for the terrain correction, a terrain correction accuracy factor. The inclusion of accuracy factors makes it possible to supplant older inferior data with newer, more accurate data with relatively little effort. In this way the file can be kept relevant and redundant data can be deleted without undue delay.

The many editing sub-routines in the reduction programs combined with the project review process insure that the data in the anomaly data file contains only the data that will be needed; in effect, there is a "curtain" drawn through the center of the system -- between project review and the anomaly data base. A user should never have to go back through the curtain.

A full discussion of the performance of the System 2000, the rationale for its adoption and the advantages and disadvantages of using it are included as the final section (2.3) in this chapter.

#### 2.2.2 Project Review

Despite the best intentions of all concerned, during the first few years of operation there were an excessive number of errors creeping into the data base. To overcome this problem two organizational changes were made:

- (i) A formal project review procedure was introduced. Under this procedure, field data is not turned over to the data base manager until it has been approved by the review committee.
- (ii) One person was designated as Data Base Administrator and only he can authorize changes to the data in the Data Base.

A relevant extract from McConnell's report follows:

"The most important item in Figure 2 is the PROJECT REVIEW. Initially, field officers were completely responsible for the reduction, editing and quality control of the data from field surveys. The data were accepted for input to the data-base when the responsible field officer said it was ready. It soon became apparent that a large number (relatively speaking) of errors were creeping into the database, and this resulted in a large number of single station updates and a large amount of time spent on tracking down and correcting problems. In a first attempt to control this problem and with infinite faith in computer programs, a large number of editing checks were incorporated into the data reduction and database load programs. The programs became so complex and the input re-

quirements so tight that they could not be easily adapted for special projects, and field officers began using unrealistic values in some of the parameters in order to get the job through. These values tended to remain until they were detected by the database load program, at which point they had to be changed and the final data reduction runs had to be done again. This system also placed a heavy burden on the data manager. As a result of these problems, and as the need arose to evaluate and accept data acquired by outside contract, the system of PROJECT REVIEW was adopted. The project review committee consists of the head of the datacentre, the programmer responsible for performing the update, the head of the field section, the scientific authority for an external contract, and the field officer who acquired the data. The field officer must present to this committee a series of documents (computer listings, station position plots, contoured plots, lists of rejected stations) according to a published set of standards. All these documents are examined and checked and are marked off on a check list. If the results are not satisfactory or if some documents are missing, the documents are returned to the field officer and he must bring them up to par. No data are accepted for inclusion into the data base until this procedure has been completed satisfactorily.

As a result of project review, the number of errors in the data base has declined dramatically, and the documents and check list resulting from the procedure provide a complete history of the project. This helps tremendously in any future reprocessing.

### 2.2.3 The Main Input Sub-Systems

There are two main inputs to the anomaly data file. There is data from the static reduction sub-system for spot measurements made on land or underwater and there is data from the dynamic reduction system for measurements made with shipborne instrumentation. The main steps in the static gravity data reduction sub-system are shown in Figure 2.4. This shows how the various field observations namely gravity data, altimetry data, electronic positioning data, and local topographic data, are merged with data from the topographic data file, from the control station data file and from the instrument data file and processed through the static gravity reduction sub-system to compute anomalies. It might appear that this last statement is in conflict with the comment above that the anomaly data base does not contain anomalies. It should be noted however, that these anomalies are computed for evaluation purposes



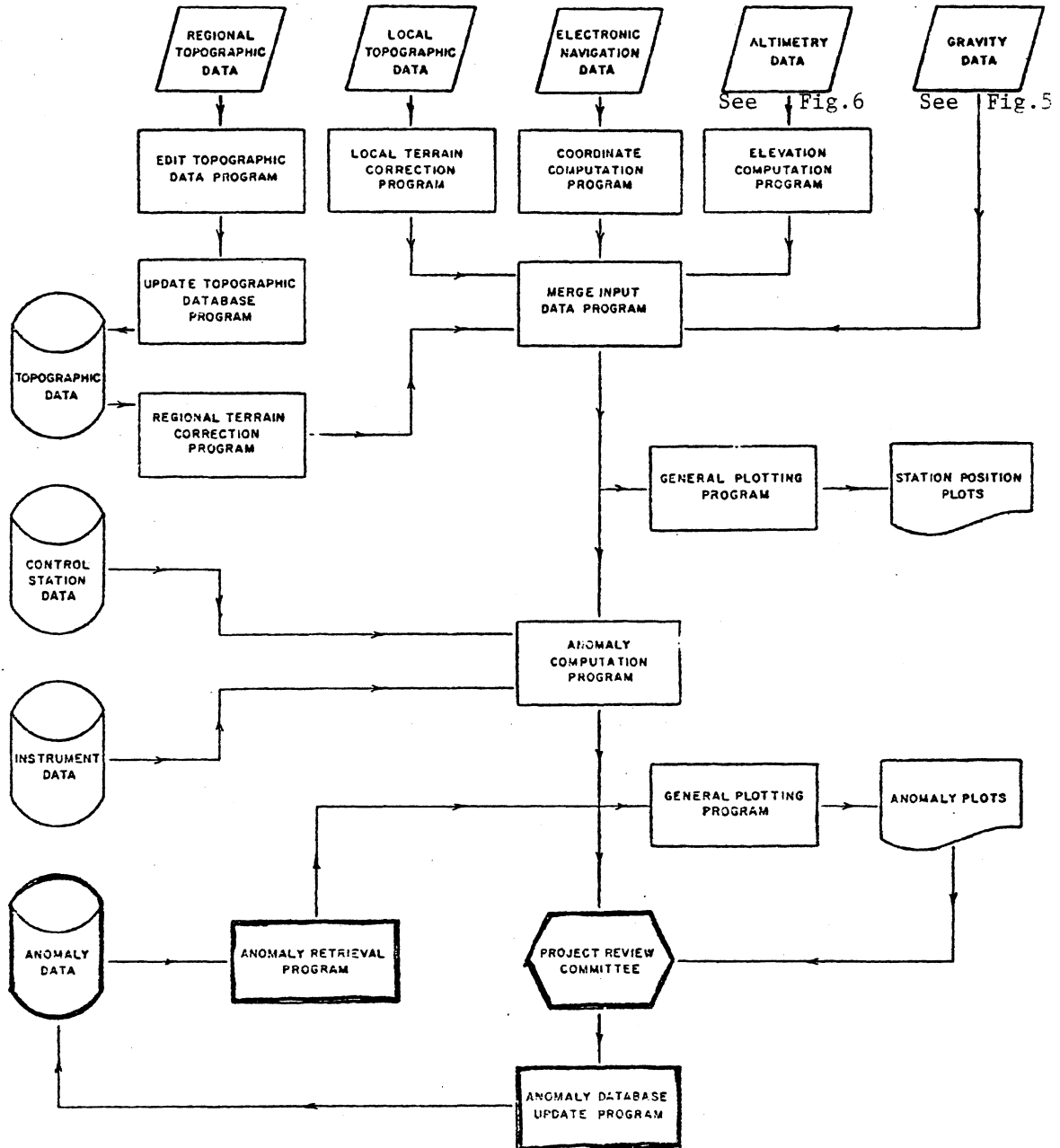

Fig. 2.4 The static gravity data reduction sub-system

AREA <u>H. A. 9557A</u>		GRAVITY DETAIL STATION CARD										OBSERVER <u>R. DICK</u>			
DATE <u>APRIL 1969</u>												PROJECT NO. <u>69-002</u>			
STATION NUMBER	YR	MO	DAY	TIME GMT	INSTRUMENT READING	INST. HT.	INST. NUMBER	F.B.	TEMP.	ELEVATION	LATITUDE NORTHINGS	LONGITUDE EASTINGS	DEPTH	TERR. CORN.	TCS
1	9090	67	07	16	16.34	285.90	W391	29		B	4	A			
	10407	69			16.41	324.20					23	4206800	433200		
	08				16.52	322.10					23	42800	354		
	109	67	07	16	17.07	267.80				572.14	11	411	342		
DISCARD STN, 10409, INST. READING, F.R.D.R.															
	10410	69	07	16	17.34	555.20	W391	29			23	622500	431600		1301
	11				17.39	551.30					23	649	267		
	10412	69			12.10	580.20					23	814	340		
2	9080	67	07	16	20.02	686.10	W391	29		B	4	A			

Code 1. first base 2. second base blank - detail stations	EAF Elevation Accuracy Factors 0. UNKNOWN 1. ±0.03 ft. or 0.01 metre 2. ±0.1 ft. or 0.03 metre 3. ±0.3 ft. or 0.1 metre 4. ±1.0 ft. or 0.3 metre 5. ±3.0 ft. or 1.0 metre 6. ±10.0 ft. or 3.0 metres 7. ±30.0 ft. or 10.0 metres 8. ±100.0 ft. or 30.0 metres	CAF Coordinate Accuracy Factor 0. UNKNOWN 1. ±3 ft. or 1 metre 2. ±30 ft. or 10 metres - 1/25,000 3. ±60 ft. or 20 metres - 1/50,000 4. ±150 ft. or 50 metres - 1/125,000 5. ±300 ft. or 100 metres - 1/250,000 6. ±600 ft. or 200 metres - 1/500,000 7. ±1200 ft. or 400 metres - 1/1,000,000 8. ±3000 ft. or 1000 metres	TCS Terrain Correction Source Factor 0. UNKNOWN 1. Bible method 2. Hammer method 3. Nagy prism method
Editing options D in col. 1 deletes record. C in col. 1 for comment statement.	EDF Elevation Datum Factor 0. UNKNOWN 1. Mean sea level 2. Sea level (uncorrected for tides) 3. Local (floating) datum	DTF Depth Type Factor 0. Depth present but not measured 1. No depth - land station 2. Depth for surface observation 3. Depth for underwater observation 4. Thickness of ice	
Instrument reading to hundredths of divisions	ESF Elevation Source Factor 0. UNKNOWN 1. Supplied by national geodetic agency 3. Taken from topographic map 5. Supplied by military agency 6. Supplied by provincial or commercial survey 7. Estimated with respect to assumed mean sea level 8. Measured on gravity survey.	DSP Depth Source Factor 0. UNKNOWN 1. Lead line 2. Pressure transducer 3. Echo Sounder 4. Seismic Soundings 5. Hydrographic chart interpolation 6. Estimated	
If elevs. are determined by barometric means, only the EDF and ESF columns should be entered. The elevation and EAF will be inserted after computation of the barometric work.	CSF Coordinate Source Factor 0. UNKNOWN 1. Geodetic Monument 2. Other Monument 3. NTS map 4. Hydro charts 5. Other maps or charts 6. Astro fixes 7. Measured survey A. Sat. Nav. B. Radar C. Loran D. Hiran E. Shoran F. Omega G. Decca H. Hifix I. Minifix J. Aerodist K. Autotape L. Photogrammetry M. Accufix N. PADS	DAF Depth Accuracy Same as Elevation Accuracy	TCA Terrain Correction Accuracy Factor 0. UNKNOWN 1. 10% of coded value 2. 20% of coded value 3. 30% of coded value
Elevations to 0.01 feet			
Depths to tenths of feet			
Coordinates to meters or hundredth of minutes ex. 50°18.20'N, 103°13.20'W			
UTM zone - must be blank for lat-long			

Fig. 2.5 Format for gravity data input to the Static Reduction Sub-System (Fig. 2.4); insets include guidelines for accuracy factors.





to ensure that the data is complete and satisfactory in order to meet the requirements of the project review.

Although it is not spelled out specifically in the anomaly computation program it is at this stage that the accuracy factors mentioned in the anomaly data file are computed. The sources from which they are computed are shown on the data observation output sheets illustrated in Figure 2.5, 2.6 and 2.7.

In this overview no attempt will be made to explain all the many steps involved in arriving at the values that finally appear in the anomaly data base. Suffice it to say that at one point a total of some 70,000 lines of Fortran coding had been written for the many programs of the Gravity Data System.

The dynamic gravity reduction sub-system is mathematically more complex than the static gravity reduction system, however there are not as many different types of data to be considered as in the static system. The steps in the flow chart (Figure 2.8) indicate where problems such as cross-overs are handled.

#### 2.2.4 Supporting Files

As mentioned previously the control data file, the instrument data file, and the topographic data file are all necessary inputs to the gravity reduction programs.

#### 2.2.5 The Network Reduction and Adjustment Sub-System

This is a major network in itself comparable in complexity to the national leveling network as maintained by the Geodetic Survey. Fortunately the cost of acquisition of the data is much, much less hence it has been possible to put an essentially complete national network of gravity control stations in place in just over a decade.

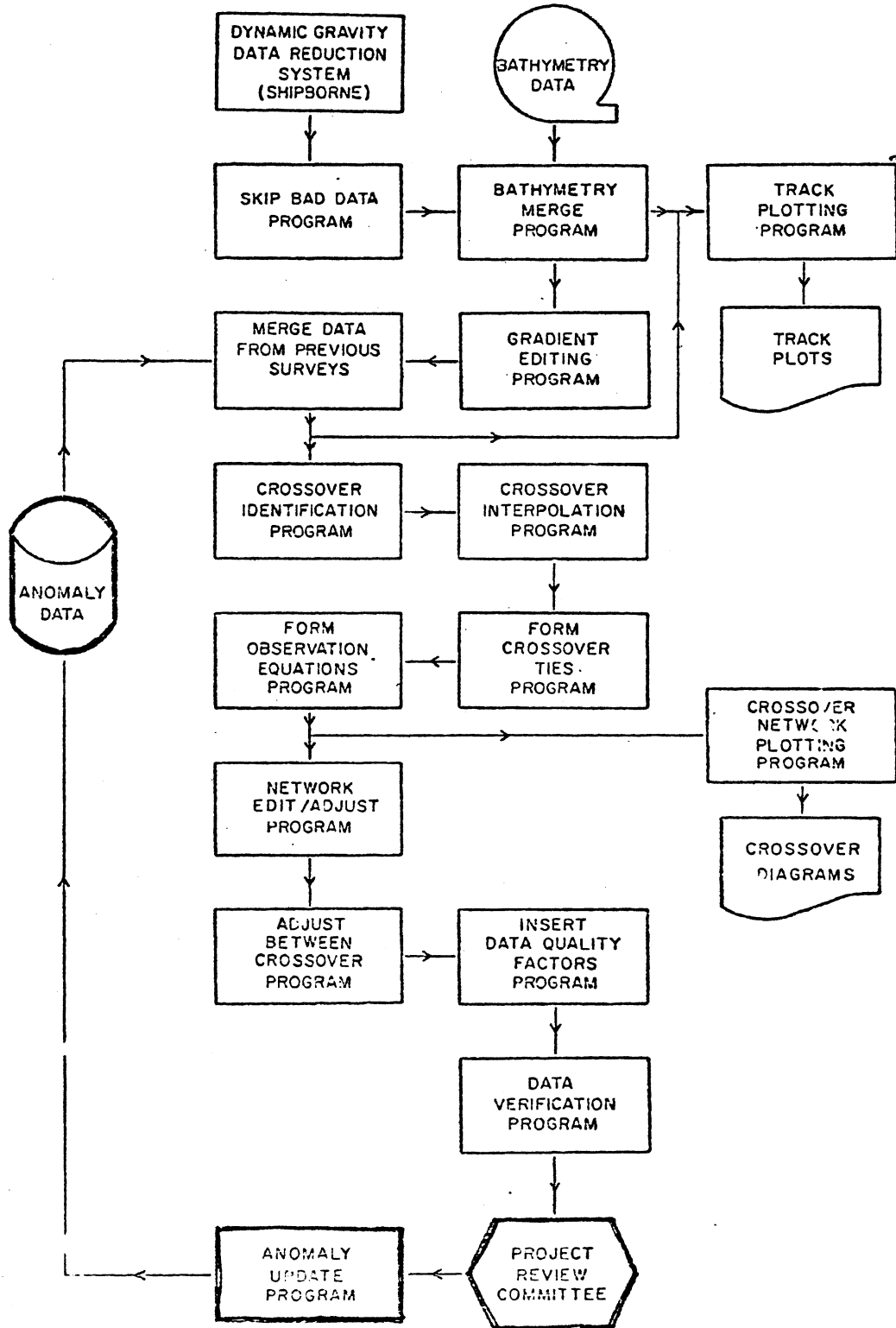

Fig. 2.8 Flow chart for the dynamic gravity sub-system.

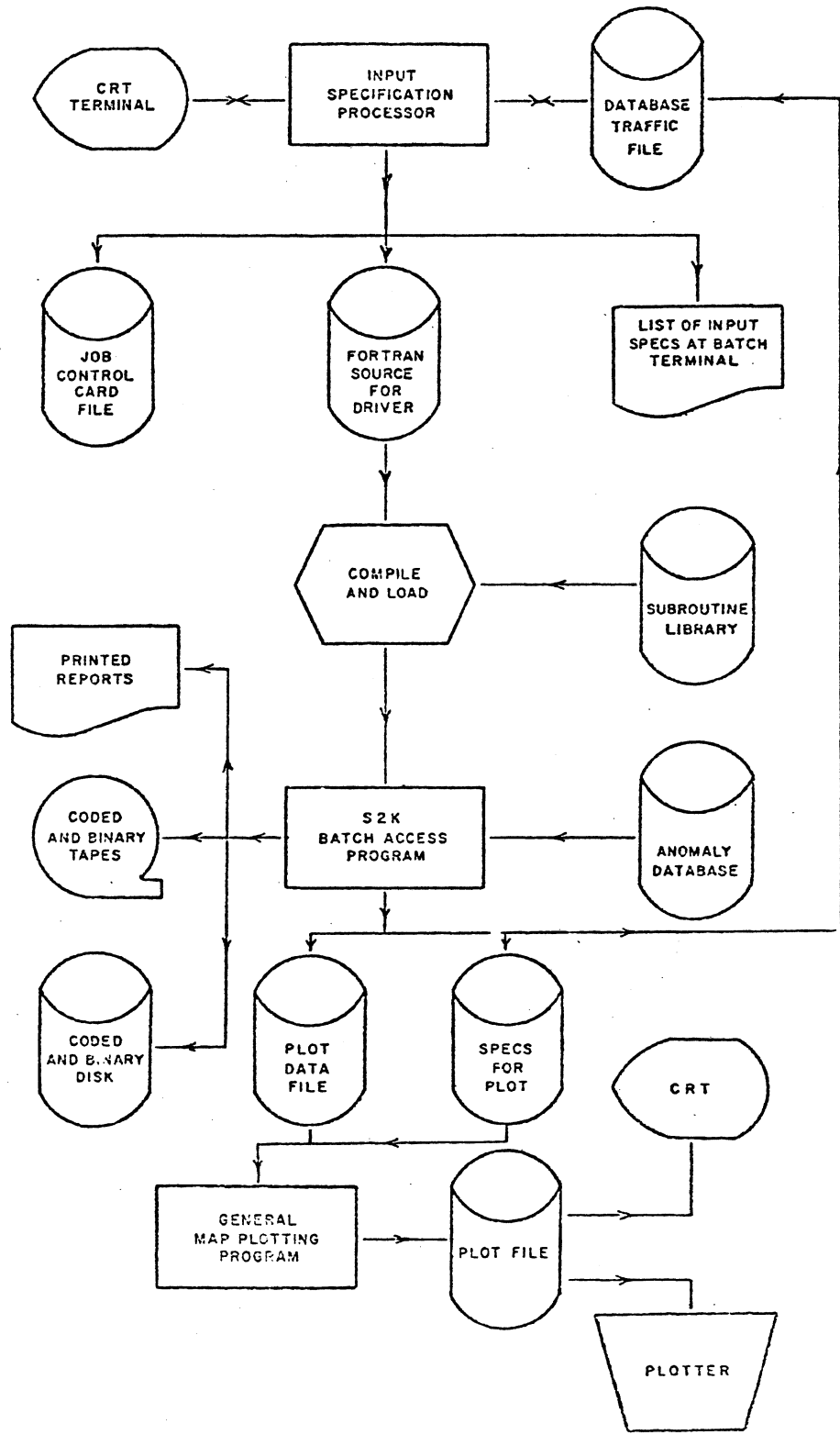

Fig. 2.9 Flow chart of the retrieval and plotting sub-system

### 2.2.6 The Retrieval and Plotting Sub-systems

Although there has been a lot of software compiled and some complex sophisticated sub-routines developed it is not necessary in this overview to elaborate on the details. It is sufficient to note that as illustrated in Figure 2.2 there is a capability for retrieving data in any desired configuration and for having it plotted on the plotter in the Gravity Data Centre.

As indicated in Figure 2.2 the point plot data, can be contoured by a contouring package program and passed along for review, revision, modification, etc. in a manual mode prior to going for printing and distribution. It is recognized that the machine contouring provides only a first pass and that it is essential for an experienced person to go over the anomaly map and make the final decisions on the contour pattern.

### 2.3 Comments on the Use of System 2000 by R.K. McConnell

"This anomaly database utilizes a commercial data base management system (DBMS) called SYSTEM 2000 (S2K); it was developed and is maintained by MRI Systems Corporation in Austin, Texas. It is available on the CDC 6000 and CYBER systems, IBM, Univac and in stripped down versions for several mini-computers. It was developed as a personnel database system for the U.S. military, and is now used by many institutions in Canada and the U.S. It has a hierarchical structure which is not particularly suited to our particular type of data, but its many other features and high degree of reliability make it preferable (for us) to a home built system. It provides:

- (a) A "natural language" which can be used for retrieval and updating. This language can be used in "immediate access" mode, where data are modified or displayed after each command, or in "queue" mode, where the requested actions are performed in batches at the end of a sequence of commands. This natural language has a Cobol-type syntax and can be used without modification in either time share (interactive) or batch processing. It can perform update and retrieval on single records or on groups of records depending on certain key data items.
- (b) A "programming language interface" to both COBOL and FORTRAN by which a programmer may imbed special update and retrieval commands in his program to produce a batch update or retrieval system. The S2K package provides a precompiler which translates



these special statements into standard COBOL and FORTRAN statements; the resulting code can then be compiled and executed using standard computer software.

- (c) A "report writer" which can be used to generate reports without the necessity of writing a batch program.
- (d) A security system whereby users may be granted or denied access to the file for updating or to parts of the file down to the level of individual data items for updating and retrieval.
- (e) Automatic backup and restore using magnetic tape.
- (f) User-defined command strings and mathematical operations.

Having developed 3 different and increasingly complex data management systems in house, and having used S2K for about three years, we can recommend the use of such a commercial package over a home-built system based on the following observations.

- (a) Very few in-house systems provide the reliability and flexibility of a package such as S2K.
- (b) Users tend to accept limitations and to find a way around them instead of demanding modifications or enhancements.
- (c) Design and development time is less than with a home-built system, since retrieval and updating software are provided; only the driver programs need be written.
- (d) The above two factors (b) and (c) reduce the load on the systems programmer; in our case, we estimate a saving of at least 6 man-months per year on maintenance alone.
- (e) Production operations can be simplified and codified and can be used by personnel with little or no programming experience. Changes and enhancements supplied by the manufacturer are almost always transparent.
- (f) Such systems are sufficiently general so that deletion, addition or modification of data item specifications or the creation of new key items are easily accomplished

of course there are trade-offs. Some of the disadvantages are:

- (a) The very flexibility and generality of such a package make it less efficient and more costly than a well designed and implemented in-house system.
- (b) The disk space required for pointer and other associated files can be up to 150% of the space required by the actual data. In our case, those overheads are less than 20% because the number of redundant data items is much less than in our previous system and this compensates in large measure for the additional system space requirements.
- (c) Because the package is relatively easy to understand and apply and because it is so general, the user can easily choose a structural arrangement which is very inefficient for his most common uses or he can encode data items in an inefficient manner. In general, these systems tend to be fast on retrieval and slow on update or vice versa according to the user's chosen structure; it is difficult to obtain a balanced system, and a considerable amount of time actually using a particular system is required before all its "peculiarities" are understood.
- (d) The user should have a detailed knowledge of his requirements for all phases of data management and of the frequency and volume of all these operations before he designs a system based on such a DBMS package. It is wise to create a test database at least 1/10 the size of the final one and use this to develop experience before the full database is implemented.

On balance, we feel that the increased expense in operating our S2K databases is more than offset by the increased efficiency that we have gained from our programming and other support staff.

### 3. ARCTIC HYDROGRAPHY DATA: PURPOSE, QUANTITY AND FLOW

#### 3.1 Purposes for which Arctic Hydrography Data is Being Collected

The need for hydrographic charting in general has been recognized for centuries and an interest in the general hydrography of Arctic waters is a legitimate task for the nation claiming sovereignty over them. However were it not virtually certain that there are sufficient hydrocarbons in the Arctic to warrant production in the near future there would still be only a very modest thrust in Arctic hydrography. As transportation by tanker is proposed as the most feasible transportation method and in view of the concern about the environmental damage that would result from an oil spill it follows that identification of all possible hazards to vessels of any type is the prime purpose for hydrographic surveys in the Arctic. Although the identification of every shoal may be an unattainable objective in the short term, the identification of shoal-free routes anywhere in the Arctic is not an unattainable goal.

Fortunately in Arctic waters which are ice-bound most, and sometimes all, of the year there are no recreational or fishing boats and hence not as great a need for large scale charts delineating the tidal zone and the near-shore shallow water areas as there is in more southerly waters. It is of course necessary to identify as many sites as possible where larger vessels can get close to shore for loading and off-loading but there is not the same need for detail throughout areas known to be shallow.

It should be noted however, that in spite of the above comments, a significant proportion of the soundings in the Arctic were collected for geophysical applications and that a large volume of water depth data would be collected in the Arctic even if there was no need for navigation charts.

Thus in this report, although the tidal zone problem will not be ignored completely, the emphasis will be put on the general problems of managing hydrographic data.

#### 3.2 The Sources and the Quantity of Arctic Hydrography Data

In order to discuss quantities in a meaningful way it is necessary to define the Arctic and to define the units used in quantifying the data.

*Arctic* - For the purpose of this study Arctic is defined as north of 60° North

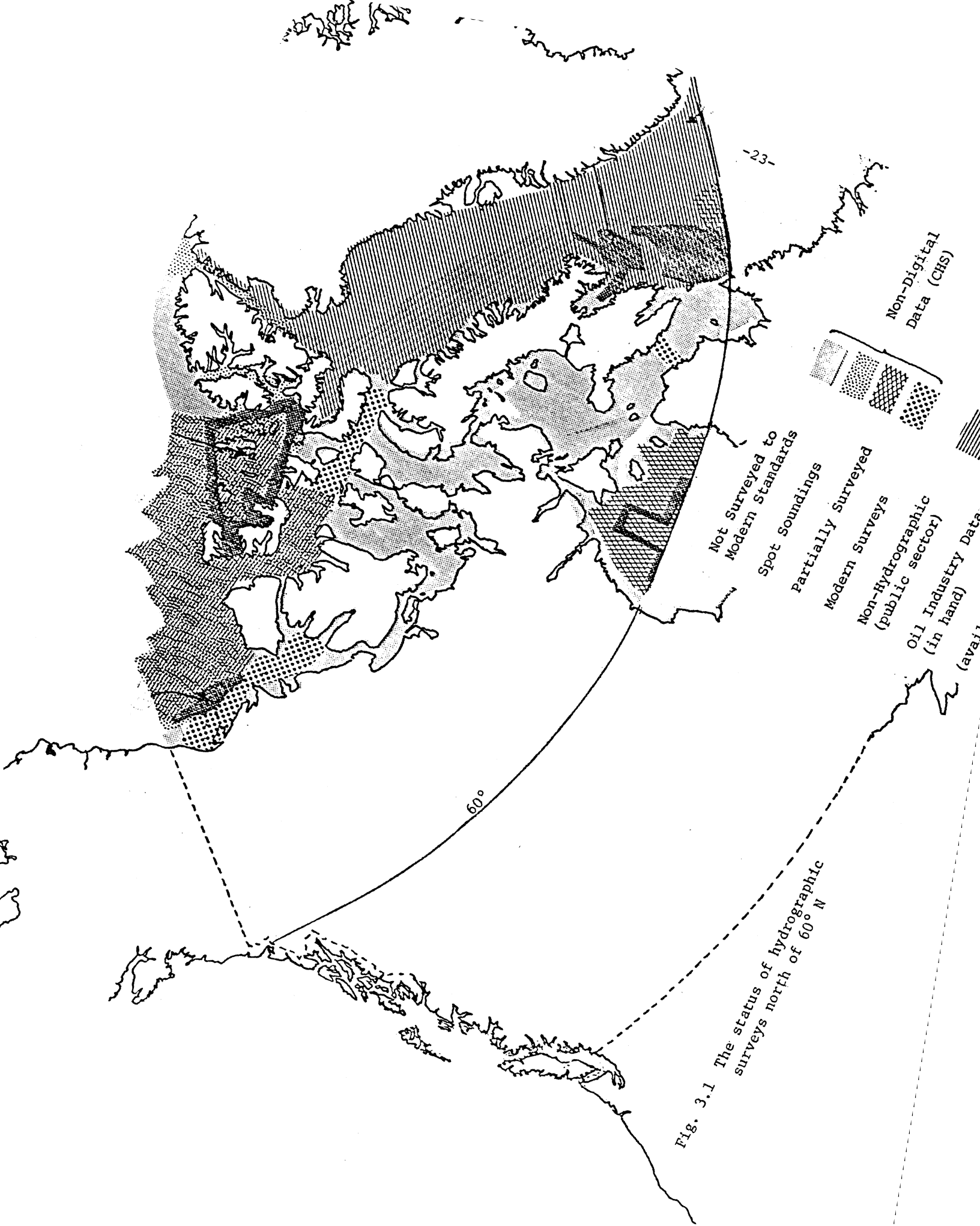

Fig. 3.1 The status of hydrographic surveys north of 60° N

latitude. Thus all of the channels between the Arctic islands are included as well as those portions of Baffin Bay, Davis Strait and the Arctic Ocean for which Canada is responsible; the total area is some 450,000 square miles. This definition excludes all of James Bay, most of Hudson Bay and a part of the Atlantic Ocean off Labrador that is commonly considered as being "Arctic". It is recognized that this is a purely arbitrary definition, however without such a definition the figures on the volume of data would be virtually meaningless.

*Units* - For the purpose of this study each sounding plotted on a field sheet in accordance with accepted practice in the C.H.S. will be accepted as one unit of data. Obviously when data are not collected as a continuous record, for example when spot soundings are made, each spot sounding will be considered as one unit. It is recognized that there are inconsistencies in this approach; however as the purpose of estimating the volume is only to establish the order of magnitude it is satisfactory. Here it should be noted that this estimate of volume is needed in order to estimate the amount and type of storage and processing facilities that will be needed.

### 3.2.1 Current (Dec. 1979) Data

The approximate status of hydrographic surveys in the Canadian Arctic is outlined in Figure 3.1 and the estimated quantity of data on file for the area north of 60° N is summarized in Table 3.1. Details on the number by type of survey, agency and year is included in Appendix A.

	<u>SOURCE</u>		
	<u>C.H.S.</u>	<u>Other</u>	<u>Totals</u>
Prior to 1970	188 900	8 000	196 900
1970-1979	<u>504 100</u>	<u>133 400</u>	<u>637 500</u>
TOTALS	693 000	141 400	834 400

Table 3.1 The number of soundings on file at the C.H.S.

As noted above the main reason for addressing the question of the quantity of data is to provide an estimate of the eventual capacity that will be needed for a data base containing all the Arctic hydrography data.

To this end the sources of data will be discussed briefly. In Table 3.1 the sources are grouped in two categories: C.H.S. and other. The C.H.S. sources will be discussed first.

*C.H.S. Data 1970-79* - The quantity of soundings by year and type of survey is summarized in Table 3.2.

Track/Recce is a term used to identify data that is not part of a systematic survey. It is collected by a hydrographer utilizing a "ship of opportunity" i.e. a ship such as an icebreaker. Under these conditions it is usually possible to get good quality in the sounding data but the quality of the positioning data may or may not be good. Specifically a position determined by navigation radar will usually be inferior to a position determined by any of the many survey positioning methods.

The quantity of track/recce data being collected will diminish with time; this is primarily because most routes followed by ships of opportunity will have already been surveyed. It will continue at a modest level however because for some years there will be some unsurveyed areas for which no other data will be available. Data from track/recce surveys is almost always processed manually.

As indicated in Figure 3.1 for many of the channels between the islands in the Western Arctic and for a sizeable sector of the Beaufort Sea spot soundings have been collected. These are made at intervals of a few kilometres in icebound areas using helicopters for transportation. Some of the spot soundings have been made in conjunction with surveys for some other parameter such as gravity and some have been made as part of the regional hydrographic surveying program.

This method provides data which is of limited value both for bathymetric mapping and nautical charting because, being discontinuous, it gives no assurances that there are no shoals in the area. Thus, as indicated in Figure 3.1 spot-sounded areas are not considered to be surveyed to modern standards. Data from spot sounding surveys collected by the Gravity Division are always processed digitally. (See Ch. 2).

Systematic offshore surveying may be done as a single ship operation

or it may be done by several launches sailing on tracks parallel to and at a predetermined distance from a large hydrographic ship and using the larger vessel as a mothership. As indicated in Table 3.2, more than 80% of all the data collected by C.H.S. between 1970 and 1979 were collected this way. Offshore surveys are usually done specifically to meet the specifications for a particular chart scale -- either 1:50 000 or 1:100 000. The methods of processing the data will be discussed subsequently.

Inshore surveys in the Arctic are almost always conducted in the same way as the offshore surveys described above except that sometimes the survey ship will stay at anchor while the launches are working. As indicated in Table 3.2 more than 30% of all the Arctic data collected by C.H.S. in the 1970-79 decade was inshore survey data. In view of the tens of thousands of miles of Arctic coastlines it can be safely assumed that inshore surveys will be continued -- probably indefinitely.

*Data from sources other than C.H.S. 1970-79* - The quantity of data acquired during the decade is itemized in Table 3.3 and the area is delineated on Figure 3.1. The term "acquired" is used intentionally here in order to emphasize the fact that the data are transferred in blocks from the institution that collected it; quite often they are held for some time (years) before being released to the C.H.S. Thus dates for data from some sources -- notably oil companies -- are of limited significance.

The data from the A.G.C. (Atlantic Geoscience Centre) tracks have been collected as part of a reconnaissance survey program; these data are usually of good quality but, in view of the separation between the tracks, can be considered reconnaissance scale only. Hence areas surveyed this way require more work to meet modern nautical chart requirements. These data are processed digitally and stored in digital format.

As noted above, the oil companies hold their soundings for some time before releasing them. Their data however is almost always of good quality and sufficiently dense for any charting requirements; it is always in digital format. Because of the high cost (>\$10,000/day) of operating a survey ship the release of oil company data to the C.H.S. enables the C.H.S. to publish more charts than would otherwise be possible. It is

1970 - 1979 ARCTIC DATA POINTS

Year	Track/Recce		Spot Soundings		Offshore F.S. Scale < 1:50,000	Inshore F.S. Scale ≥ 1:50,000	TOTAL
	Radar	Controlled	> 2 Km	≤ 2 Km			
1970	9,292	1,520	1,363		35,878	52,592	100,645
1971	11,993		1,639	821	44,813	10,207	69,473
1972	6,883			70	29,612	2,963	39,528
1973	182		3,061	3,579	48,979	7,962	63,763
1974	1,623		2,793	1,396	8,097	3,483	17,392
1975	1,595	2,150	2,092	896	2,508	39,849	49,090 <sup>1</sup>
1976	3,979	2,406		8,705		21,058	36,148
1977	2,651		5,887	3,235	29,929	33,324	75,026
1978	216		8,160	907	20,564		29,847
1979	590			12,787		9,812	23,189
TOTAL	39,004	6,076	24,995	32,396	220,380	181,250	504,101

Table 3.2 - C.H.S. Arctic Data 1970 - 1979  
 Compilation by the Planning Section of the C.H.S.



1970-1979 ARCTIC DATA POINTS

<u>YEAR</u>	<u>AGC SHIP TRACKS</u>	<u>EPB SPOT DEPTHS</u>	<u>MEDS</u>	<u>ESSO RESOURCES</u>	<u>CANADA CITIES SERVICE</u>
1970	28058				
1971	12000				
1972		1960-1978	Various	Various	Various
1973		= 15655	Years	Years	Years
1974	20000				
1975	4000				
1976	18507				
1977	7904				
1978		1223			
1979					
	<u>90469</u>	<u>16878</u>	<u>4100</u>	<u>10 000</u>	<u>12 000</u>

TOTAL of Digital Data (1970-1979) = 133 447 values

Total of all Data (including prior to 1970) = 141 425 values.

Table 3.3 - Data from other sources, 1970 - 1979  
 Compilation by the G.E.B.C.O. section of the C.H.S.

anticipated that quite a lot more data will in time be released the the oil companies.

### 3.2.2. Projected Quantity of Data

During the 1970-79 decade some 637 000 soundings were added to the 197 000 already in the C.H.S. file of Arctic data at the beginning of the decade. As mentioned previously the purpose in discussing quantity is only to establish the order of magnitude of the data that any data base would in time be required to handle.

There are at least two possible approaches to forecasting storage requirements. One could extrapolate from the present rate of acquisition or one could make assumptions about the total required to bring the charting of the area up to "standard". Both approaches have shortcomings.

From a quick look at Figures 3.2 and 3.3 it appears that 1970 was a year of unusually high activity and hence should be disregarded insofar as trends are concerned. By so doing an annual minimum of some 15 000 soundings and an annual maximum of some 70 000 is indicated; recognizing that the more accessible areas have been completed one is inclined to lean towards the lower end of the range, say 30 000 or 35 000 per year. Thus during the next ten years it can be anticipated that a lower limit of some 200 000 soundings and an upper limit of some 1 000 000 soundings will be collected. From this it appears that a storage facility capable of handling 2 000 000 soundings would be adequate until at least 1990.

### 3.3 The Flow of Arctic Hydrography Data

In addition to having an estimate of the volume of data it is necessary to have an understanding of the main steps involved in interpreting storing and using Arctic hydrographic data. These are shown symbolically in Figure 3.2.

Although, as discussed above, there are several ways in which surveys are conducted there are only two significantly different techniques — namely continuous recording and spot sounding. Continuous recording is the technique used in collecting Track/Recce data (see Table 3.1) and on systematic surveys whether inshore or offshore. Spot sounding is the only

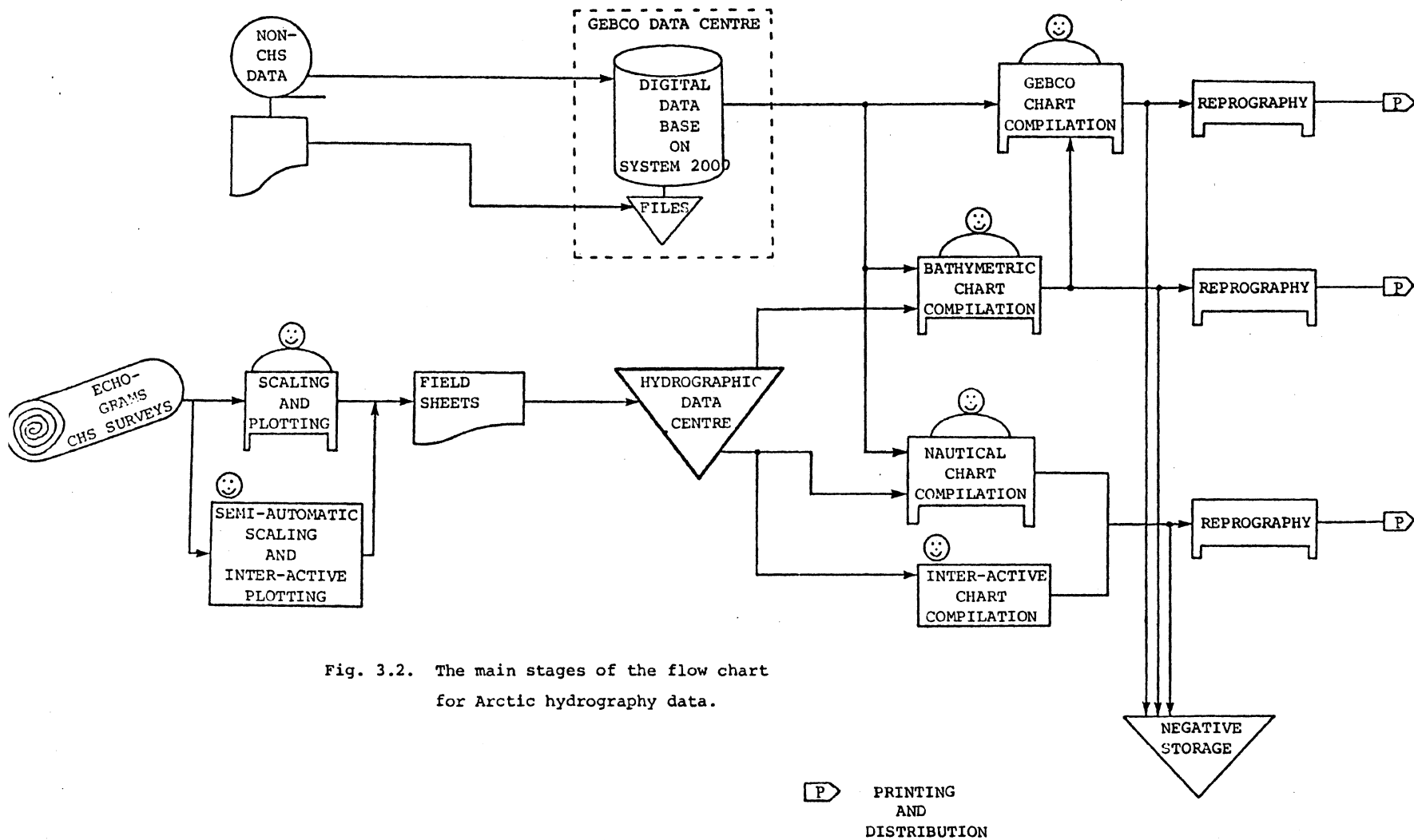

practical method of collecting soundings in ice covered areas; in view of the fact that for many areas in the Arctic there may be open water only at very rare intervals it is not surprising that, as indicated on Figure 3.1, the spot sounding method has been used extensively.

Regardless of the technique used in gathering the data it is standard practice to compile a field sheet for each survey project; this may be done manually or semi-automatically. Copies of the field sheets, original sounding records, calibration data, etc. are turned over for filing in the Hydrographic Data Centre repository. Although it is only capable of handling data in hard copy (paper, film, etc.) format, it is, in effect, the data base for the C.H.S.

When revision of an existing chart is being considered or when production of a new chart is being planned the first step is to search the H.D.C. files for the field sheets of all C.H.S. surveys and for any other data within the boundaries of the chart. In view of the fact that there are data files on hundreds of projects in the H.D.C. it is not surprising that occasionally relevant data is overlooked.

Even though digital procedures may be used in the data reduction prior to field sheet compilation and an inter-active sub-system (GOMADS) may be used in chart compilation it is, essentially, a graphic system with digital phases.

#### 4. ALTERNATIVES FOR MANAGING ARCTIC HYDROGRAPHY DATA

Comparison of the flow chart for the National Gravity Data System shown in Figure 2.2 with the flow chart for Arctic hydrography data shown in Figure 3.2 reveals a fundamental difference in concept and philosophy. In the former it is clear that the data in the anomaly data base is the focal point of the Gravity Data System; all the activities prior to the deposition of the data are directed to ensuring that the data meets the requirements for filing and all the subsequent steps are directed towards using the data from this base. In other words the anomaly data base is a multi-purpose entity and the project review process serves as a one-way *curtain*.

In the C.H.S. there is no focal point in the system comparable to the gravity anomaly data base. The Hydrographic Data Centre (H.D.C.) might be compared with the anomaly data base but in fact the differences are much more pronounced than the similarities. The main difference is that the H.D.C. is operated as a repository or an archive for data in hard copy format. This data apparently is accepted into the H.D.C. without any formal screening process comparable to the Project Review described in Section 2.2.2 and hence there is no one-way curtain to limit the amount of effort spent in re-reviewing older data. In fact, there seem to be several focal points, namely: field sheet compilation, nautical chart compilation, as well as the GEBCO data base and the bathymetric chart production. On further analysis it appears that the compiled field sheets are the closest parallel to the gravity anomaly data base. The striking difference, of course, is that the definitive values are on the field sheets in graphical format whereas in the N.G.D.S. the definitive values are in digital form; needless to say there may be a copy of the field sheet data on a digital file somewhere and of course there are manuscript copies of the anomaly data of the N.G.D.S.

Although there are countless possibilities for managing the Arctic hydrography data three distinctly different alternatives can be identified. One alternative would be a digitally-oriented system with graphic phases; this would be comparable in concept to the National Gravity Data System. Another alternative would be a graphically-oriented system with digital phases; this is essentially what there is now. Yet another alternative would be to assume that new sensor technology will make it easier and cheaper to

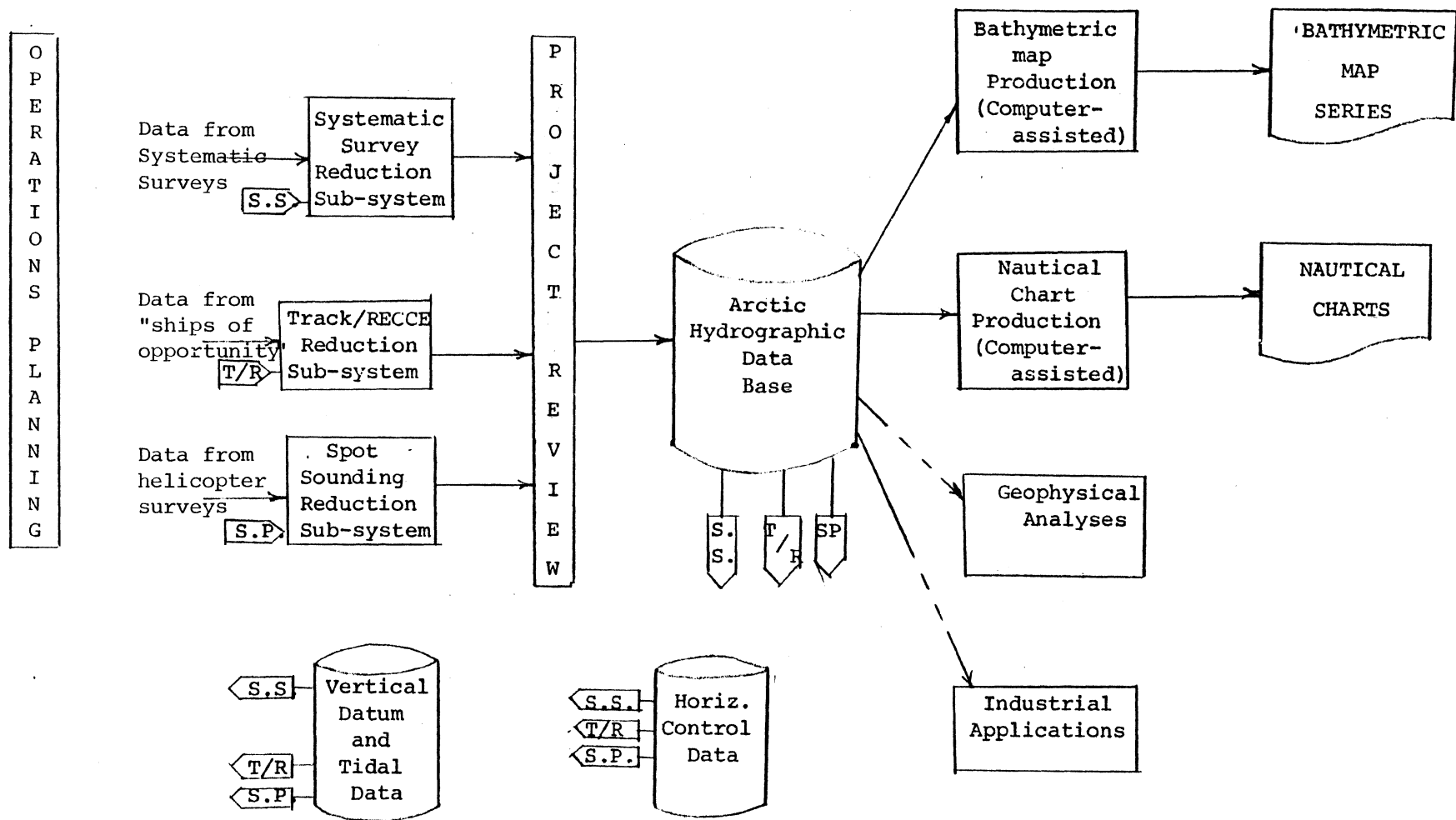

Figure 4.1 The principal components of a digitally-oriented Arctic hydrography data system.

collect new data than to maintain an effective data base and hence that there is no need for actively managing the data at all. Each of these will be discussed briefly.

#### 4.1 Alternative #1 - A Digitally-Oriented System with Graphic Phases

In this alternative an edited digital multi-purpose data base of Arctic hydrography data similar to the data base in the National Gravity Data System would become the focal point for the Arctic Hydrography Data System (A.H.D.S.). Its main features are shown on the flow chart in Figure 4.1.

It is implied in this alternative that the conventional procedures for compiling field sheets would be significantly revised. Although a comprehensive review of alternative methods for processing hydrographic soundings is beyond the scope of this study a few observations, albeit superficial, follow:

- (i) There seems to be a sound argument in favor of an inter-active procedure rather than a purely automated procedure for digitizing echograms.
- (ii) There does not seem to be any fundamental reason that procedures similar to those used in the dynamic gravity data adjustment sub-system cannot be developed for processing virtually all offshore and most inshore hydrographic data.

It is recognized that (ii) above may call for some re-thinking of the somewhat subjective traditional procedures but, by giving the hydrographer an "over-ride" option, it should be possible to develop effective sub-systems for reducing systematic surveys, track/recce surveys and spot soundings. Again, as for the N.G.D.S., it is proposed that a formal review process be adopted before accepting data into the Arctic hydrography data base. It follows, too, that digital files for horizontal control data and for vertical datum data and tidal data would be essential components of the system. From the authors' experience there is no doubt that the key to a successful system is the inclusion of quality factors. In reflection on the reasons most often cited for not adopting digital or semi-automated procedures it is clear that the argument hinges on the application of

judgement to the quality of the data. This is a very valid point; in a semi-automated system there must still be provision for judgement to be applied. The controversy arises over where it should be applied. With purely manual systems the accumulated experience of many decades leads to the best way -- or ways -- of applying judgement. With digital or semi-automated procedures the point or points at which judgement can most effectively be applied are not necessarily the same as with manual procedures. Because there were no traditional procedures for processing gravity data when digital methods were being introduced into the N.G.D.S. it was relatively easy to introduce a system that was digitally-oriented.

As discussed briefly in the discussion of the N.G.D.S. in Chapter 2, an accuracy factor is assigned to every observed quantity. The reduction sub-system then includes algorithms for combining these accuracy factors in order to get one accuracy factor for the final anomaly value. Manual intervention can occur at the input stage, at any of the intermediate editing stages and at the final map compilation stage. It is clear that to be effective similar procedures are needed for the successful functioning of the Arctic hydrography data base.

To reach a decision on the final definition of the accuracy factors is beyond the scope of this study. It is suggested however that a judicious combination of the factors being used for the N.G.D.S. and those proposed by the IHO Committee (See appendix B2) be drafted and tested.

#### 4.2 Alternative #2 - A Graphically-Oriented System with Digital Phases

This alternative can be described very briefly; it is simply to continue with the present system. As illustrated in Figure 3.2 and discussed previously this is a graphically-oriented system. In this alternative digital reduction sub-routines are viewed only as labor-saving aids in the compiling of field sheets and of preparing charts. The principle storage medium is hard copy data in tabular and graphic format.

#### 4.3 Alternative #3 - The No-System Approach

In considering alternatives we would be remiss if we did not list the possibility of assuming that hydrographic data could be treated in the



same way as most consumer items in North America i.e. it could be considered as disposable.

In view of the fact that new and ever-more sensitive sensors are appearing each year is it necessary to be concerned about a system for managing hydrographic data? If in a decade or so some method of *instant* chart production could be foreseen, then the best strategy for the interim would be to improvise by any means possible. Regrettably, attractive though this alternative would be, there do not seem to be any bright ideas for instrumentation that would rapidly and economically provide hydrographic data at the scale and accuracy needed. Even if one or more of the scanning lidar or aerial hydrography systems that are currently being developed do become operational it will still be necessary to fly at low altitude along many, many kilometres of track and to put a lot of effort into the interpretation of the results. Especially in the hostile Arctic environment it appears that for the foreseeable future it will be necessary to use "ships of opportunity", geophysical surveys and various other resourceful strategies along with many systematic surveys just to get the minimum amount of data needed for charting. Thus we can conclude that alternative #3 is not viable.

#### 4.4. Comparison of Alternatives 1 and 2

From previous comments it should be apparent that the difference between a digitally-oriented system with graphic phases and a graphically-oriented system with digital phases is conceptually quite subtle. In the digitally-oriented concept a graphic product is regarded only as an aid to help the human mind comprehend the basic data; in the graphically-oriented concept the chart is the main concern and the data is only a means to that end.

Although it is an interesting topic for debate on a philosophical level we will resist the temptation and we will simply look at the question in very practical terms, i.e. we will attempt to identify the advantages and disadvantages of each approach. These are summarized in Table 4.1 and discussed briefly below:

## Digitally-oriented

### Advantages

1. Flexibility
  - (a) Changes in horizontal control or in vertical or horizontal datum can be made at any time with minimal effort.
  - (b) Many different selections of data can be made at will. For example only data of a certain accuracy can be selected.
  - (c) New data can easily be merged with existing data.
  - (d) Selection of data for charts at various scales and for bathymetric and GEBCO charts is facilitated.
2. Objectivity

Agreed upon standards used to assess the quality of the input.
3. New applications become possible:
  - (a) Computation of underwater terrain effects on geophysical parameters,
  - (b) A correlator on a submarine could automatically compare the soundings observed with the digital model of the ocean floor as a check on its position.

### Disadvantages

1. Considerable time needed to bring data up to the standards required for project review

## Graphically-oriented

### Advantages

1. Adhering as closely as possible to traditional methods ensures continuity in the system.

### Disadvantages

1. Inflexible for changes in datum or scale; even the change to metric units poses a major problem.
2. Subjectivity. Each compiler and each editor can "interpret" data differently.

### Transitional problems

1. Considerable re-training and re-orientation of staff.
2. Some difficulties in quality control of final product until transition completed.

Table 4.1 Advantages and disadvantages of digitally-oriented and graphically-oriented approach to managing Arctic hydrography data.

*Flexibility* - There are two aspects to flexibility to be discussed. There is flexibility with respect to the input and flexibility with respect to the output. Regardless of the system used, the original raw data, the echogram reading and the time, should never be altered. However, it is quite probable that for any of the other parameters improved values may become available at some future time; this includes the calibration of the echo sounder, velocity, horizontal control coordinates, horizontal control datum, vertical control value, vertical control datum, and tidal correction. With a digitally-oriented system in which there is an appropriate reduction sub-system the new values can be inserted in the appropriate file and the soundings can be updated at the cost of a few minutes in computer time. Thus if, as anticipated, there is in a few years a change in the North American geodetic datum, with a digitally-oriented system it would be a relatively minor step to change all the effected soundings.

In a region in which new data is being added piecemeal the problem of merging data will recur. In a digitally-oriented system with appropriate accuracy factors on all parameters it will be relatively easy to merge the data and to delete data below any specified accuracy.

There are many eloquent treatises expounding the virtues of the flexibility available to the cartographer when he has data in a digital format. Usually the freedom to compile at different scales is cited as one of the biggest advantages; the relative ease of chart revision is another.

Noting that for some military applications such as for the Cruise missile the digital model of the terrain is compared automatically with the input from on-board sensors as a check of position, it would not be unreasonable to anticipate that mariners or submariners could make good use of a similar application.

*Objectivity and subjectivity* - The adoption of the digitally-oriented approach does not mean that human judgement is to be disregarded. It does mean however that it will be introduced at a different stage and in a different way than it is with a graphically-oriented system. Specifically, in the digitally-oriented approach judgement is applied in assessing the

accuracy of all the parameters at the time or soon after the sounding is made and also at the time the sounding is being digitized. Thereafter all the steps should be performed objectively with the exception of the project review. At the project review stage subjectivity may be applied to the assessment procedures in general but not to individual soundings. In other words, the project review would serve as an audit on each hydrographer's interpretation of the standards to ensure parity between projects. Otherwise the data would all be processed in the same way and the only opportunity for human intervention would be in detecting and eliminating errors.

*Time and costs* - Drawing on the experience of those responsible for the N.G.D.S. considerable effort is required to bring projects up to the standards required for project review. This effort involves both computer time and individuals' time. As errors have to be eliminated at some stage prior to the production of a chart there is no reason to expect that it will be more costly to do it prior to the project review stage than at some later stage.

As discussed above under flexibility, if any change in datum or scale or a change to metric units is required, it can be anticipated that it will be much more economical on a digitally-oriented system than on a graphical system. Also if the semi-automated method of chart production becomes routine then the availability of data in digital format will certainly make a significant contribution to the cost-effectiveness of the system.

## 5. AN IMPLEMENTATION SCENARIO

### 5.1 Hydrographic Data in Nautical Chart Production.

Although soundings and features such as shoals that are identified by soundings are the *sine qua non* for a nautical chart there are several other essential themes.

Of these the most important are the navigational aids such as marker buoys, beacons, light-houses, radio beacons and the lattices of radio navigation systems such as Loran.

It is necessary not only to delineate the foreshore (tidal zone) by means of low water and high water lines but in addition it is necessary to portray all the topographical features that are either near the shore or are visible landmarks from offshore. In addition the chart must include several other themes such as the isolines of magnetic declination, names, horizontal and vertical control markers, etc.

It will be useful to list these themes in a table along with the agencies having both the primary and the secondary responsibility for them.

<u>Theme</u>	<u>Primary sources</u>	<u>Secondary sources</u>
Hydrography	C.H.S.	The offshore exploration industry
Foreshore (tidal zone)	C.H.S.	Topo Survey and provincial Survey Agencies
Topography	Topographical Survey	Provincial mapping agencies
Navigation Aids	Ministry of Transport	
Names	Canadian Permanent Committee on Geographical Names, DEMR	Provincial Committees on Geographical Names
Magnetic Declinations	Geomagnetism Division E.P.B., D.E.M.R.	
Horizontal & Vertical Control	Geodetic Survey, DEMR	Provincial Survey Agencies and the Nautical Geodesy Section of C.H.S.

Table 5.1 The principle themes of a nautical chart and the agencies responsible for management of the data of each theme.

There are two distinctly different ways to organize the flow of data for nautical chart production. These are shown in Figure 5.1.

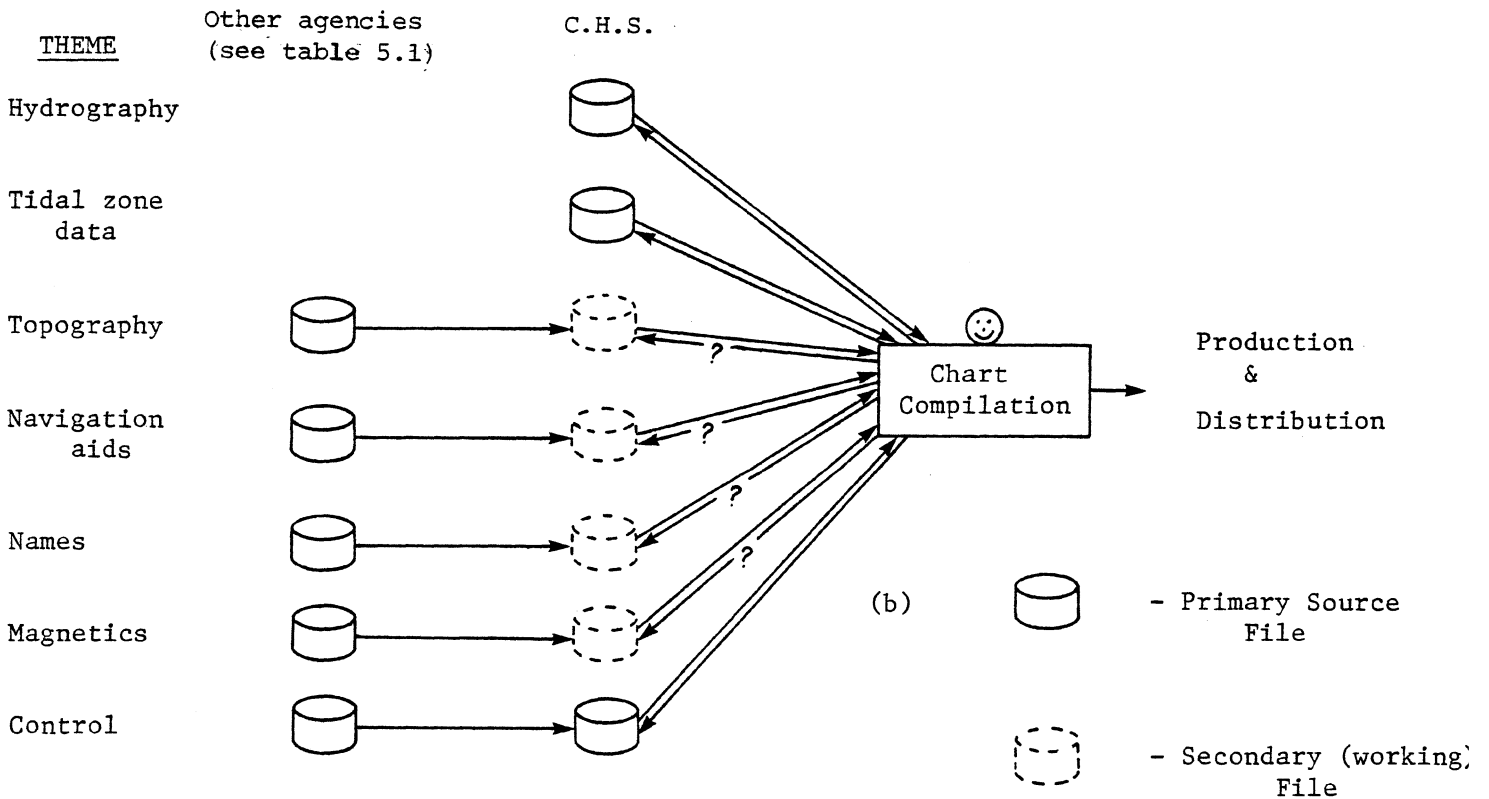
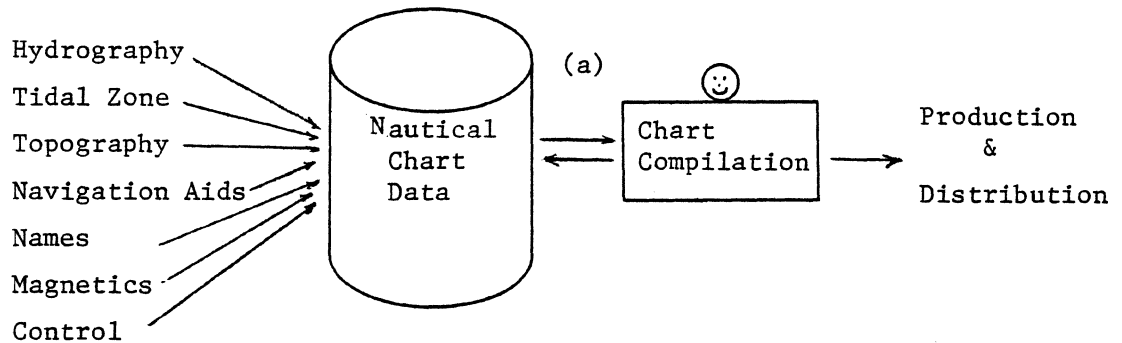

Figure 5.1 Two conceptual models for the management of nautical chart data. In (a) every possible bit of data likely to be needed for chart compilation is collected and stored in one large data base; in (b) there are separate data bases or files for each theme.

In the model outlined in Figure 5.1a there would be one large repository (data base) in which every bit of data likely to be needed for chart compilation would be stored, feature by feature. On completion of the compilation of a chart a list of those features selected for publication would be sent back to the data base and a notation "published in chart No. xx" would be appended to the feature. This general concept has been followed in the design of the Automated Information System that has been assembled and is being tested at the National Ocean Survey in Washington. This system is described in the paper by W.G. Swisher that is included as Appendix C1.

In the model outlined in Figure 5.1b there would be several data bases, or data files rather than one large data base. For three of these— hydrography, tidal zone data, and survey control data - separate but compatible data bases would be maintained by C.H.S.; for four of them - topography, navigation aids, names and magnetics only working files would be maintained by C.H.S. For the latter group, as indicated in Table 5.1, and in Figure 5.1b some agency other than C.H.S. has the primary data management responsibility; whether or not a "working file" of published data should be maintained for this group is a question that can be left open at the conceptual model stage.

Those who are familiar with the present procedures may be surprised to see that in both models it is suggested that data on the tidal zone, also called the foreshore, is designated for its own data base separate from hydrography.

The delineation of the foreshore by high and low water lines and the description of its character usually require maps and air photographs as well as soundings and on-site observation data from the hydrographer's field notes. In other words it is a complex task that calls for the type of synthesis and judgement that can be done readily by a trained person but which cannot be easily defined objectively for automated processing. On the other hand, as discussed in the preceding chapters, there does not seem to be any reason that the procedure for processing soundings beyond the low water line cannot be defined objectively and hence processed with a large degree of automation.

In other words a graphically-oriented system with digital phases should continue to be used for foreshore data and a digitally-oriented system

with graphic phases should be developed for all other hydrographic data. Thus looking at nautical chart production in perspective the following scenario appears:

Theme	<u>1980</u>	<u>Method</u>	<u>1985</u>
Neat line, grids lattices, etc.	Automated procedures operational and proven effective.		continue
Hydrography	A graphically-oriented system with digital phases.		A digitally-oriented system with graphic phases.
Tidal zone data	A graphically-oriented system with digital phases.		A graphically-oriented system with digital phases.
Topography	A graphically-oriented system with digital phases.		Dependent in part on the approach taken by Topographic Survey,
Navigation Aids	A graphically-oriented system with digital phases.		Dependent in part on the approach taken by the Ministry of Transport.
Names	A graphically-oriented system with digital phases.		Dependent in part on the approach of the Toponymy Division of S&M Branch.
Magnetics	A graphically-oriented system with digital phases.		Dependent in part on the approach taken by the Earth Physics Branch.
Control	A digitally-oriented approach with graphic phases.		Automated procedures fully operational.

In summary, because nautical chart data comes from several sources it appears that automation of nautical chart compilation ought to proceed theme by theme. Specifically at this time, it appears that there are neither institutional nor technological constraints to the establishment of a digitally-oriented system for managing all hydrographic soundings beyond the low water line.

## 5.2 The People Factor

In every structured group of people a certain *culture* evolves rather quickly and changes rather slowly. One of the major management challenges is the introduction of new concepts without excessive passive resistance. Changing the *culture* of a group is a much more complex task than laying on a course of instruction.



Techniques can be taught in a classroom situation and some of the *culture* of the group can be transmitted to recruits but generally the *culture* - the dogma on methodology in general - cannot be significantly changed in a teacher-student situation. To change people's attitudes a much higher level of involvement is necessary. One of the best ways to achieve this is through a problem-solving workshop. With this approach a selected group of individuals are given a challenging question along with all available relevant input and are asked to arrive at a concensus on it.

In the context of this study of Arctic hydrography data the question can be expressed as: "Is a change in the approach to the management of Arctic hydrography data necessary? If so, what procedures can be recommended?"

A tentative list of categories of participants and of relevant input for a workshop to address this question is included in Appendix D. For an example of the workshop format the reader is referred to "Surveying Offshore Lands for Mineral Resource Development"; it is the report from a workshop held in Ottawa, January 12 to February 20, 1970.

### 5.3 Suggested Sequence of Steps for Developing a New Approach to the Management of Arctic Hydrography Data

1. A decision to proceed to Phase II of the development of a new approach to the management of Arctic hydrography data (This study can be considered as Phase I).
  2. The organization of a Workshop along the lines suggested in Appendix D. It is anticipated that the Workshop report would include:
    - (a) A restatement of the general guidelines for managing Arctic hydrographic data.
    - (b) Some restructuring of the responsibilities for data management.
    - (c) The types and categories of accuracy factors, if it is agreed that they are to be adopted.
    - (d) Specifications, in general terms, for the subroutine packages, etc. that will be needed.
  3. A decision to proceed to Phase III. Phase III would be implementation of the steps defined in the report of the Workshop.
  4. A conceptual study on the management of foreshore (tidal zone) data.
- It should be noted that Step 4 could proceed independently of Steps 2 and 3.

APPENDIX A

Arctic hydrography data by type and year

Part I - CHS Arctic data 1970 - 1979

- Fig. A-1 Total Arctic track/reconnaissance (radar) data point collected 1970 - 1979 - 39,004.
- Fig. A-2 Total Arctic track/reconnaissance (controlled) data points collected 1970 - 1979 - 6067.
- Fig. A-3 Total Arctic spot sounding (line spacing > 2 Km) data points 1970 - 1979 - 24,995.
- Fig. A-4 Total spot sounding (line spacing < .2 Km) data points collected 1970 - 1979 - 32,396.
- Fig. A-5 Total Arctic offshore data points collected 1970 - 1979 - 220,380.
- Fig. A-6 Total Arctic inshore data points collected 1970 - 1979 - 181,250.
- Fig. A-7 Total Arctic data points collected 1970 - 1979 - 504, 101.

Part II - CHS Arctic data 1960 - 1969

- Table A-1 CHS Arctic data by type and by year, 1960 - 1969.
- Fig. A-8 CHS Arctic data by year 1960 - 1969.

DATA POINTS COLLECTED 1970-1979

Fig. A-1 - Total Arctic track/reconnaissance (radar) data points collected 1970-1979 - 39,004.

ARCTIC TRACK/RECONNAISSANCE (CONTROLLED)  
SOUNDING DATA POINTS COLLECTED 1970-1979

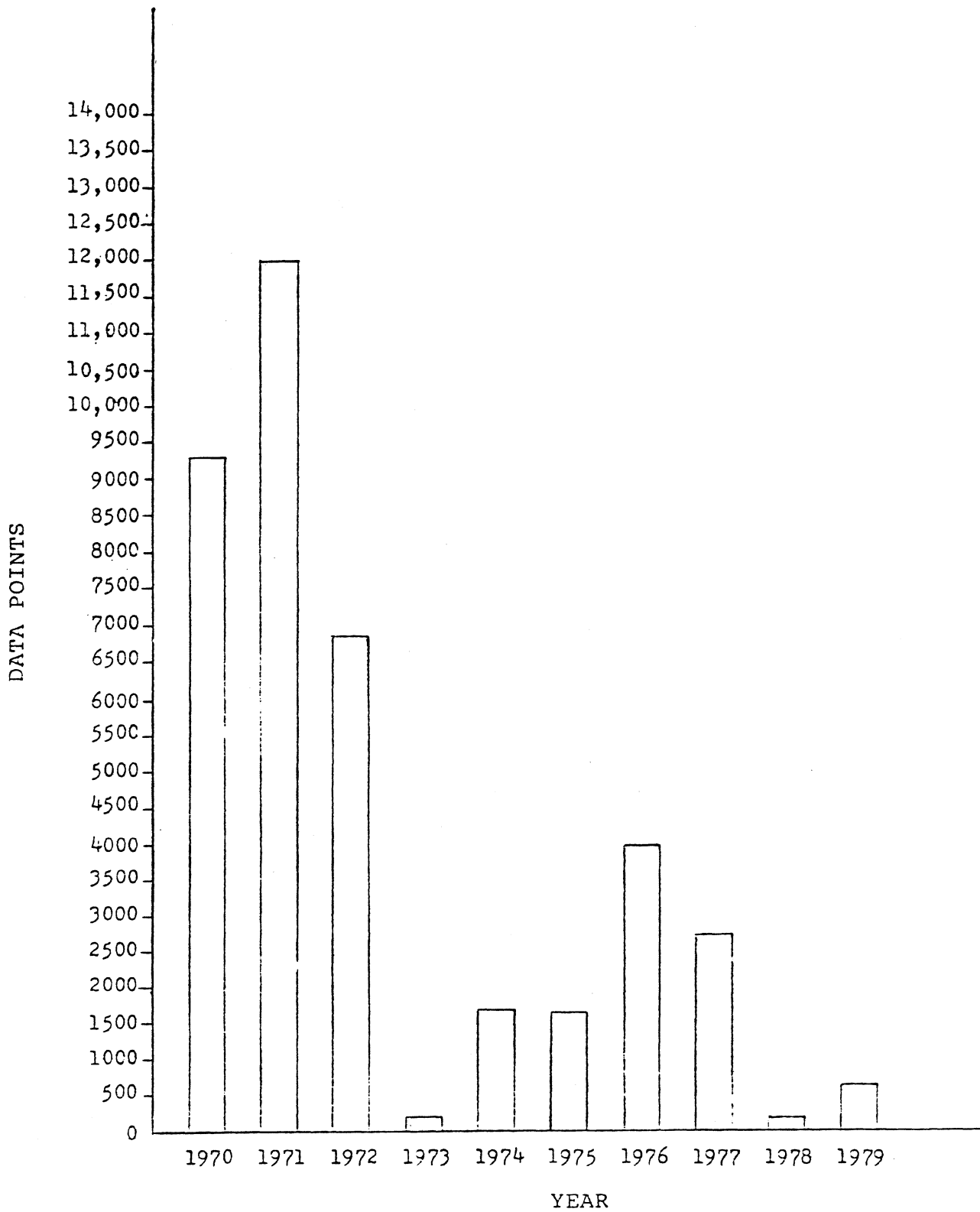
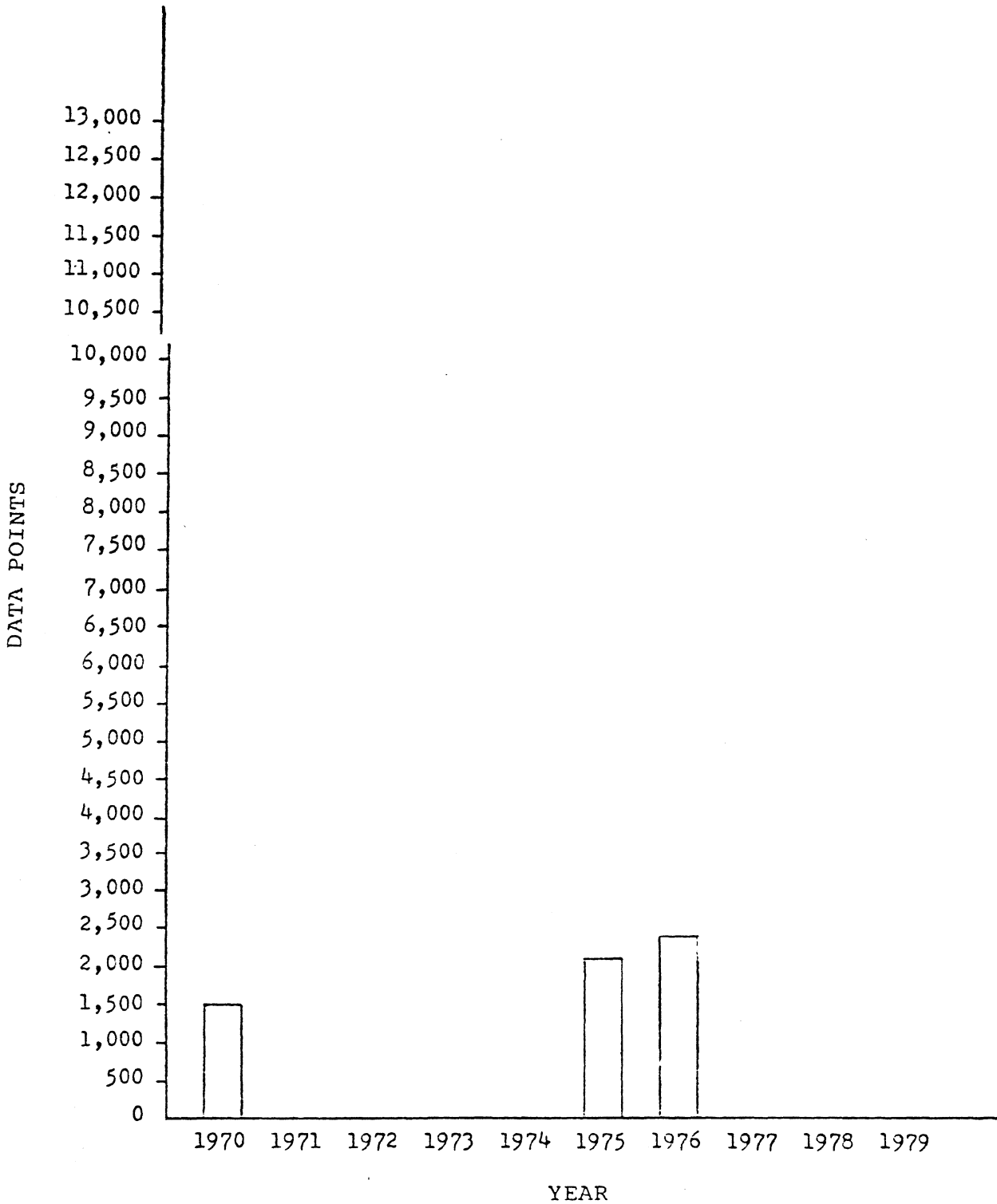

Fig. A-2 - Total Arctic track/reconnaissance (controlled) data points collected 1970-1979 - 6076.

ARCTIC SPOT SOUNDING (LINE SPACING > 2Km)  
DATA POINTS COLLECTED 1970-1979

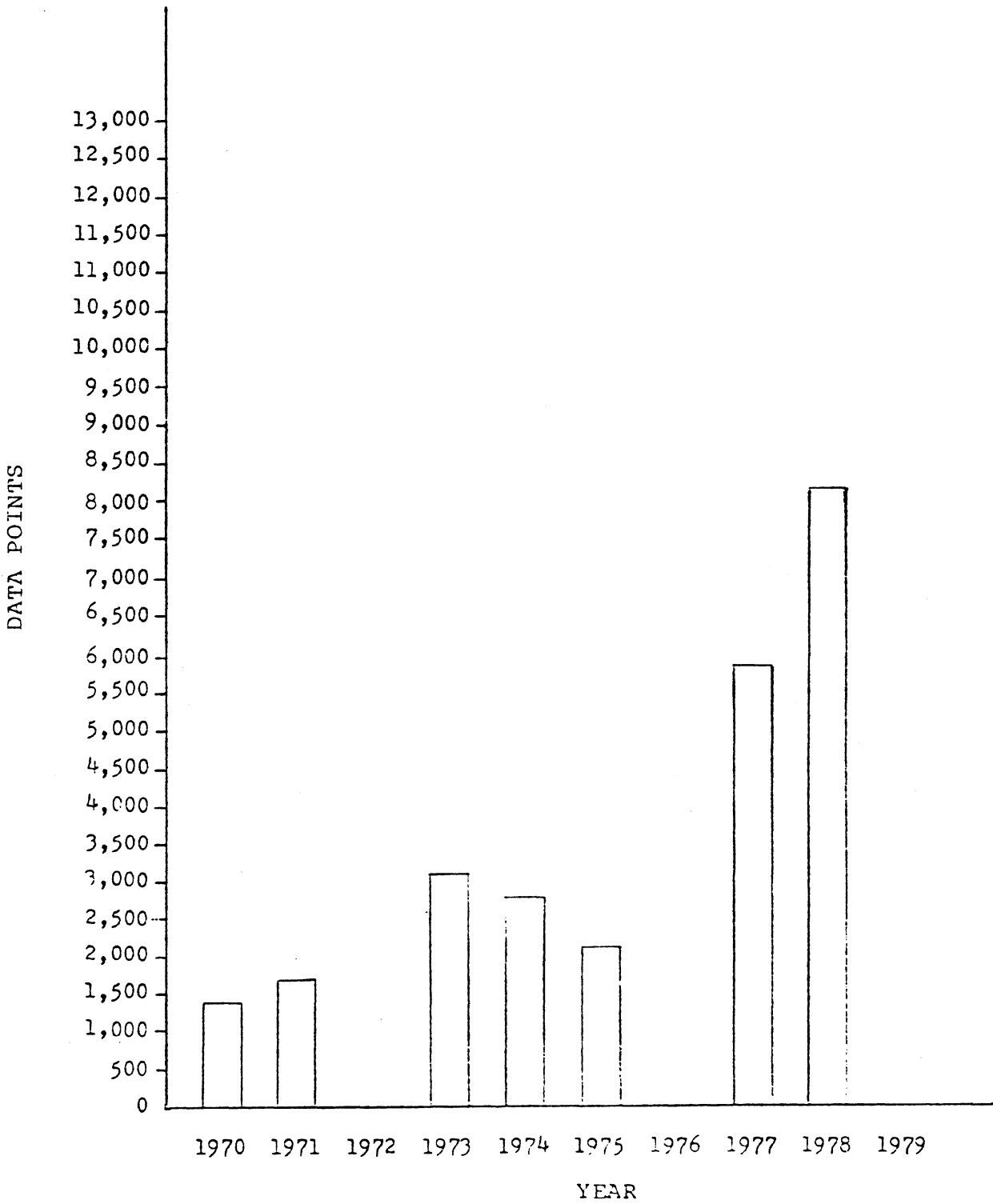

Fig. A-3 -Total Arctic spot sounding (line spacing > 2 Km)  
data points 1970-1979 - 24,995.

ARCTIC SPOT SOUNDING (LINE SPACING  $\leq$  2Km)

DATA POINTS COLLECTED 1970-1979

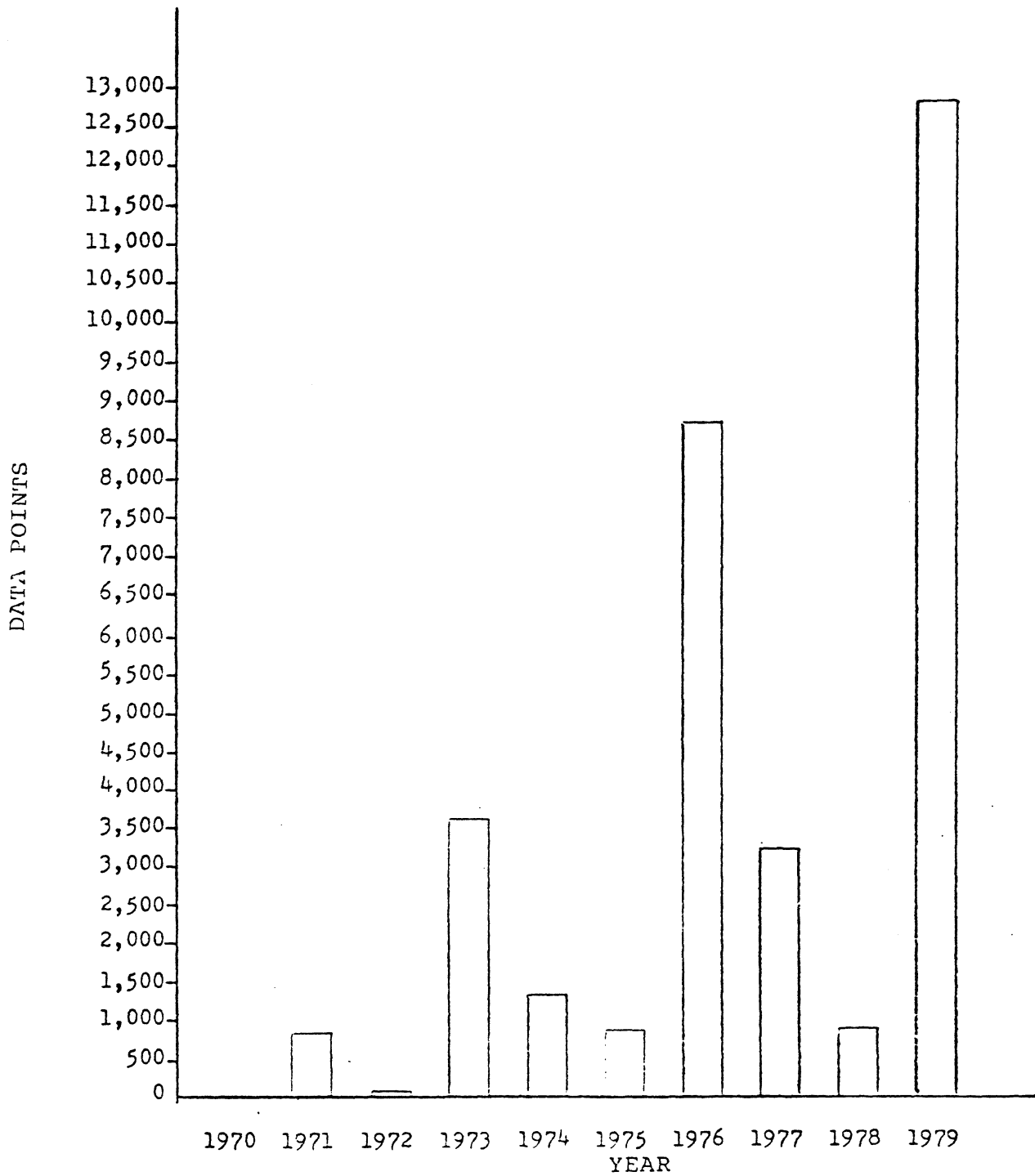

Fig. A-4 - Total spot sounding (line spacing  $\leq$  2Km) data points collected 1970-1979 - 32,396.

ARCTIC OFFSHORE (SCALE 1:50,000)

DATA POINTS COLLECTED 1970-1979

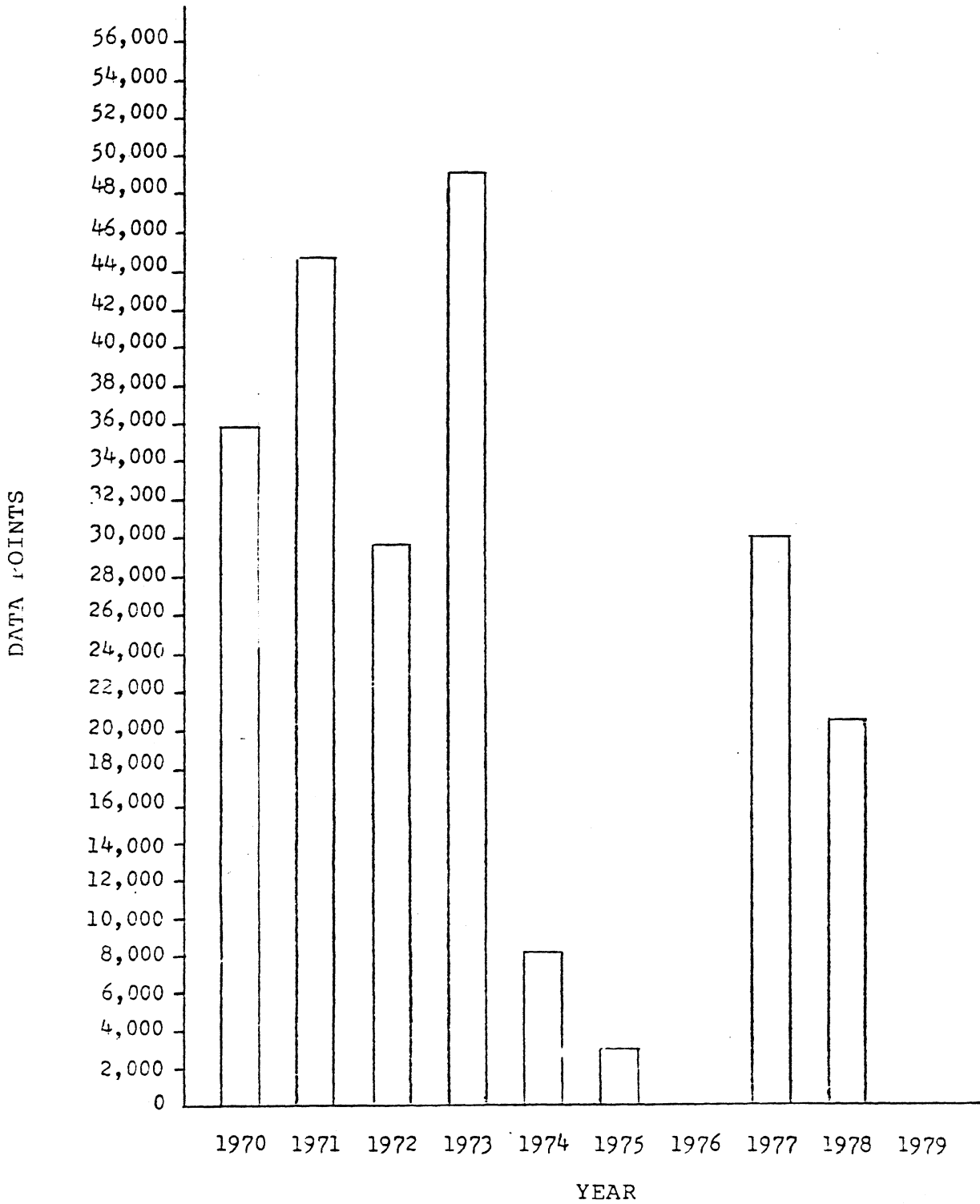

Fig. A-5 - Total Arctic offshore data points collected 1970-1979 - 220,380.

ARCTIC INSHORE (SCALE  $\geq 1:50,000$ )

DATA POINTS COLLECTED 1970-1979

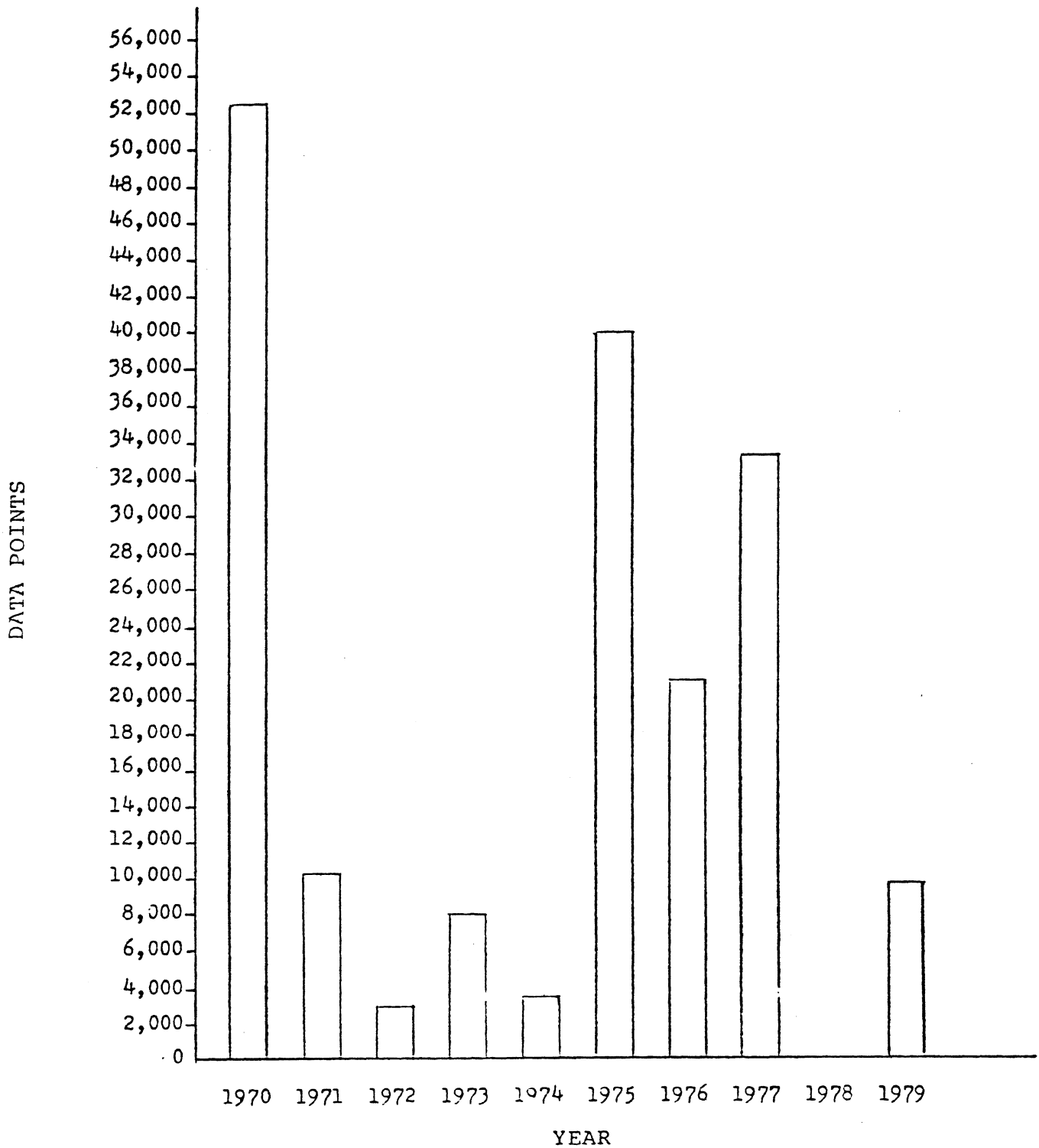

Fig. A-6 - Total Arctic inshore data points collected 1970-1979 -  
181, 250.



ANNUAL TOTALS OF ARCTIC DATA POINTS COLLECTED 1970-1979

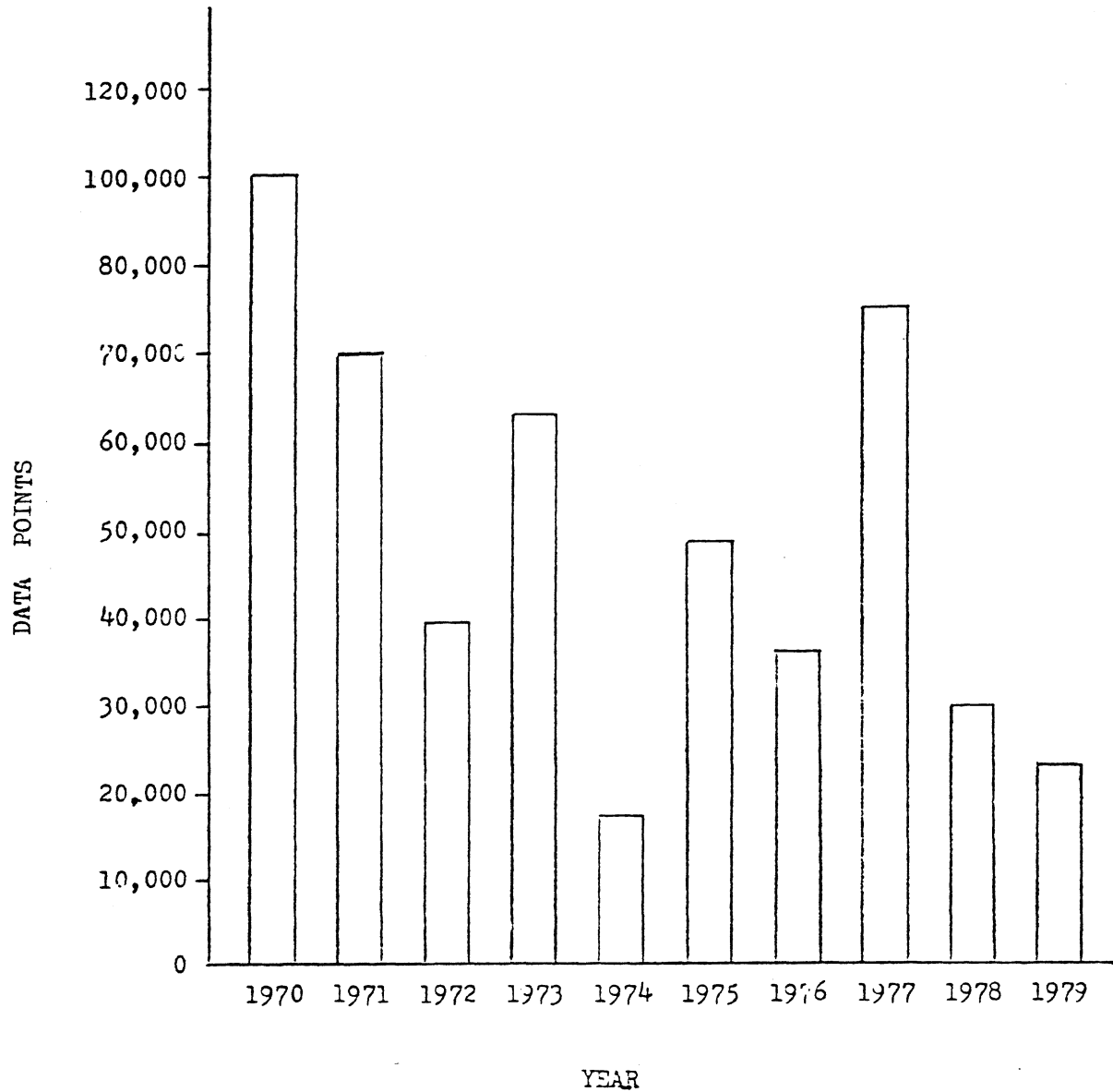

Fig. A-7 - Total Arctic data points collected 1970-1979 - 504,101

1960 - 1969 ARCTIC DATA POINTS

Year	Spot Soundings		Offshore F.S. Scale < 1:50,000	Inshore F.S. ≥ 1:50,000	TOTAL
	> 2 Km	≤ 2 Km			
1960			12,000	12,032	24,032
1961	1,538		11,692	18,297	31,527
1962	1,315		12,485	4,260	18,060
1963				5,495	5,495
1964	1,110		7,845	10,138	19,093
1965	1,522			8,501	10,023
1966		406		23,398	23,804
1967			4,683	4,429	9,112
1968	2,081			35,979	38,060
1969	539			9,182	9,721
TOTAL	8,105	406	48,705	131,711	188,927

Table A-1

ANNUAL TOTALS OF ARCTIC DATA POINTS COLLECTED 1960-1969

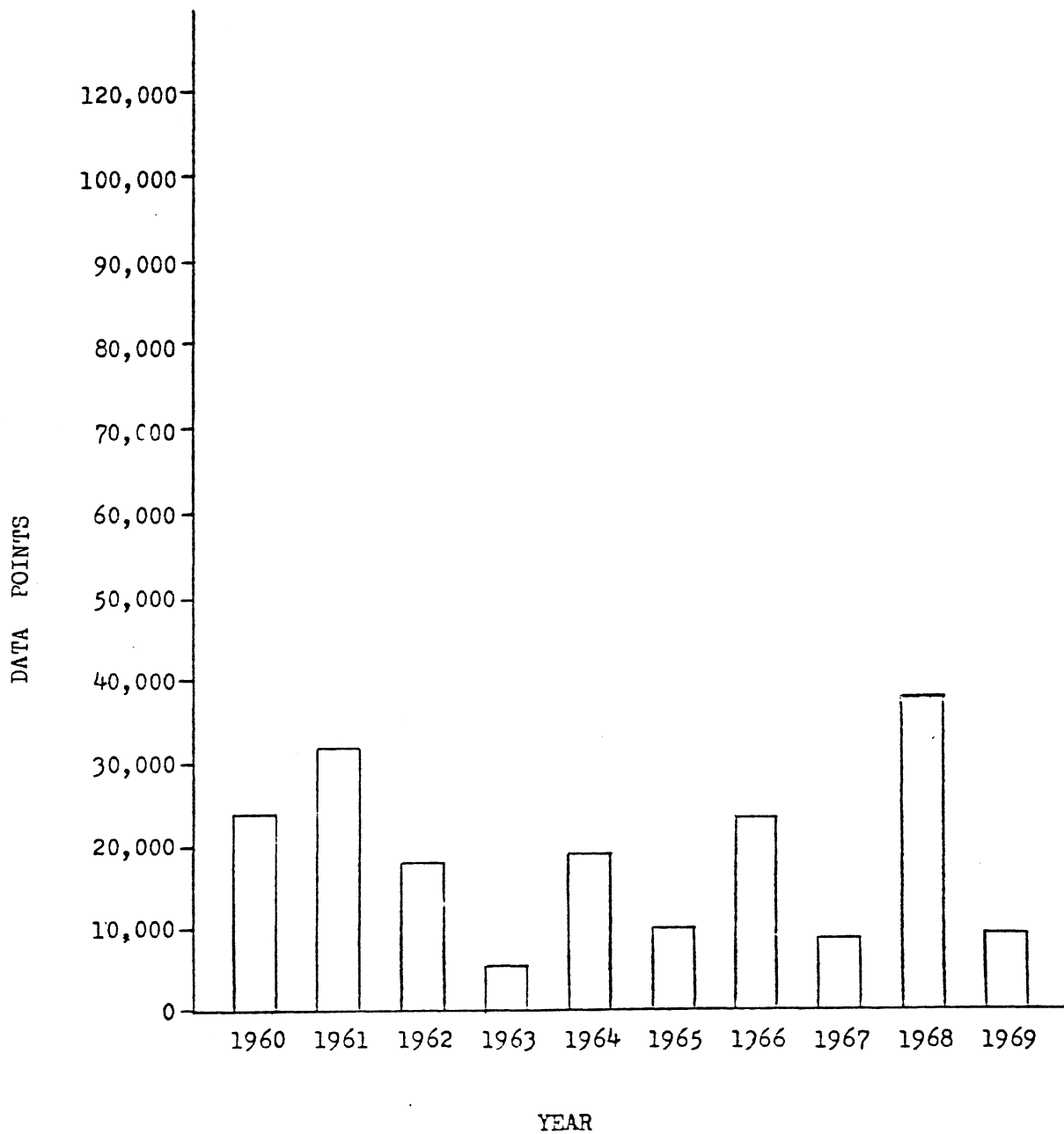

Total Arctic data points collected 1960-1969 -  
188,927

Fig. A-8

APPENDIX B

CLASSIFICATION CRITERIA FOR DEEP OCEAN SOUNDINGS

REPORT OF I.H.O. WORKING GROUP - 1976

INTRODUCTION

1. This classification is designed to meet International Hydrographic Organization technical resolution K 18.1 of 1972:

"In view of the rapid improvements in technology with respect to deep ocean surveys and the increase in demand for bathymetric data by technological and scientific users, it is resolved that the IHB establish a Working Group that shall be charged with the responsibility of establishing classification criteria for the quality of deep ocean soundings with respect to position and depth measurements."

2. The aim of compiling deep ocean soundings is to map the shape of the seabed. The interest is scientific as much as it is navigational, as distinct from the aim of a hydrographic chart, which must emphasize hazards to navigation.
3. The aim of classifying ocean soundings is to select the better data where overlapping soundings disagree. It will also be needed should the requirement arise to compile charts on which all data meets a specified minimum standard.
4. "Deep Ocean" soundings implies depths greater than 200 m.

CLASSIFICATION

1. The classification is deliberately extended beyond current techniques and GEBCO requirements, with the intention that it should fit future technical developments and meet more rigorous chart-making requirements.
2. The classification is made under four headings:
  - Position Accuracy, with sub-headings: Track/Systematic Survey, Position Accuracy;
  - Sounding Accuracy, with sub-headings: Beamwidth, Timing Accuracy;
  - Fidelity of scaling soundings to reproduce seabed;
  - Data processing, with sub-headings: whether original data supplied, Method of Correcting Soundings.

The reasons for preferring this over a single code are:

- (i) A multiple code where each characteristic is judged separately is easier for the observer to apply than a single, combination, code; the number of combinations required to classify all the information required in a single code would make coding a complicated process. A multiple code is also easier to adjust when one characteristic changes during the course of a cruise; this will often happen with positioning accuracy. for example

- (ii) The compiler needs detailed information on some aspects of the classification. Take for example the dilemma that positioning is more important than sounding accuracy on a steeply sloping seabed, whereas sounding accuracy is more important over an abyssal plain; the only practical solution appears to be to classify position and sounding accuracy independently, and leave the final decision to the compiler.
- 3. The steps between each category have deliberately been made large, in order to simplify classification, and to discourage exaggerated claims by making them ridiculous.
- 4. Each code has a "Z" category for "unspecified" data. This may be old data or current data submitted without accuracy classification. Categories A, B, and C of each code are left unused in case of future developments.
- 5. Some notes on the Data Processing Code:
  - (i) This code should describe the form of the data when it is finally entered into the data bank.
  - (ii) The significance of submitting original soundings as observed is that the corrected depth can be refined should improved sound velocity become available after the original work was done.
  - (iii) Perhaps the most serious weakness in the present day process of reporting ocean soundings is that only a very small part of data collected is preserved; for example, spot sounding at 10 km. intervals. out of a continuous seabed profile. Codes A, B and C are intended for the day when a continuous profile can be stored (on magnetic tape?) and used to reproduce all the information gathered.
- 6. The roughness of the seabed is an important factor in judging the fidelity with which spot soundings can reproduce a continuous profile, but it is a difficult quality to classify. The Fidelity of Scaling Soundings code gives the limited information that either the bottom roughness has been described by the sounding selection (category D), or it is rougher than the soundings indicate.
- 7. The classification should be applied by the ship collecting the soundings, and amended if necessary by the National Hydrographic Office concerned if it processes the data further before passing it on to the authority responsible for compiling the chart and storing the data.
- 8. Several members of the Working Group thought it useful to know what type of ship collected the soundings. As this is not strictly a classification criterion, it is recommended that this information be requested separately, as a heading to each sheet of data submitted.
- 9. To apply this classification to data already collected is probably impracticable, if not impossible. This in no way implies that old data should be discarded, but it does mean that its quality is hard to judge and that classified data of high quality should be preferred over it where the two coincide.

10. Note that this scheme requires additional work beyond simply recording the classification code. For example, the geodetic datum used must be reported when geographic position accuracy is high (see Position Accuracy code, note 3); and arrangements to store raw sounding data will be needed (see Data Processing code).
11. It is often difficult to judge the accuracy of positioning. The IHB is encouraged to take every opportunity to assist mariners in doing this, such as publishing an up-dated version of S.P. 39.

POSITION ACCURACY - 2nd REVISION

In mapping the seabed, a systematic survey of a large area with high relative position accuracy is the equivalent of a series of single tracks of equivalent geographical accuracy. To reflect this, the code consists of a number specifying whether the sounding is from an area survey, in which case relative accuracy is specified; or from a single track, in which case geographic accuracy should be specified; following by a letter specifying the accuracy.

SINGLE TRACK OR SYSTEMATIC SURVEY

CATEGORY

1. Sounding is from a single track. In this case the sounding position accuracy coded below must be the geographical accuracy.
2. Sounding is from a systematic survey of a large area. In this case sounding position accuracy should be the relative accuracy between soundings in the survey area, so long as the geographical accuracy is within a one category step.

<u>CATEGORY</u>	<u>ACCURACY OF 95% OF SOUNDING POSITIONS</u>	<u>EXAMPLE OF METHOD GIVING THAT ACCURACY</u>
D.	Better than <u>+100 m</u> (0.05 NM)	Ranging on seabed acoustic transponders.
E.	Better than <u>+300 m</u> (0.15 NM)	Medium frequency phase comparison radio positioning system
F.	Better than <u>+1 km</u> (0.5 NM)	Low frequency radio navaid, (e.g. Decca)
G.	Better than <u>+3 km</u> (2.0 NM)	Very low frequency radio navaid (e.g. Omega) with corrections from a monitor within 500 km. or satellite navigation, ship on steady track.
H.	Better than <u>+ 10 km</u> (5 NM)	Celestial or satellite navigation, ship manoeuvring between fixes.
(I. -----	Omitted Intentionally)	
J.	Worse than <u>+10 km</u> (5 NM)	Dead reckoning.
Z.	Position accuracy not specified	

NOTES: 1. The accuracy refers to the positions of soundings, and may be lower than the accuracy of the position fixes if soundings are interpolated between fixes.

2. If positions are read off a plotting sheet, the scale of the sheet sets an upper limit on the accuracy of the positions.

3. The differences between geodetic datums, and between a local datum and a geocentric, satellite navigation, datum, may amount to several hundred metres. For geographic accuracies better than  $\pm 1$  km. (categories 1D, 1E, 1F, 2D, and 2E) the datum used must be defined, either by a recognised term (eg. "Tokyo datum, Bessel ellipsoid") or by quoting the reference ellipsoid's  $a$  and  $1/f$  and the datum translation components  $X_0$ ,  $Y_0$ ,  $Z_0$  that give the coordinates of the centre of the datum relative to the geocentre. (If the Navy Navigation Satellite System is used, its centre can be assumed to be at the geocentre).

EXAMPLE A systematic offshore survey by Loran-C which had relative accuracy of better than 1 km. (0.5 NM) but which was not calibrated and so could have geographic position error of up to 3 km. (2.0 NM) would be classified "2F".



SOUNDING ACCURACY - 2nd REVISION

The accuracy with which the sounder can map the seafloor depends on the precision with which it measures the return travel time of the echo, and on the width of the beam, since a wide beam distorts the shape of the seabed. To reflect this, the code consists of a number specifying the beamwidth followed by a letter specifying the time and recording accuracy (which will be matched in a well-designed sounder)

<u>CATEGORY</u>	<u>BEAMWIDTH</u>
1.	Very narrow beam; total beamwidth less than 6° to -3db point, or sounder deep-towed or in submersible such that dimension of area "illuminated" is less than 1/10 of water depth.
2.	Narrow beam; total beamwidth less than 12° to -3db point, or dimension of area illuminated less than 1/5 of water depth.
3.	Normal beamwidth, total beamwidth greater than 12° to -3db point.

<u>CATEGORY</u>	<u>TIMING</u>	<u>RECORDING</u>
D	High precision, better than 0.1% of travel time.	High precision; stable dry paper, or calibration marks applied by timer to give recording accuracy of +0.1%. Digital recording to be same precision.
E	Better than 2% of travel time.	Better than 2% of depth.
F	Less accurate than 2%.	Less accurate than 2%.
Z	Sounding accuracy not specified.	

NOTES: 1. The depth of the transducer (ships draught, or depth of deep towed sounder or submersible), and any instrumental time corrections, must be measured with the same accuracy as the sounding.

2. Where the tidal range is significant (e.g. over a level-topped seamount), tide reductions should be measured with the same accuracy as the sounding. (From limited observations, ocean tides are thought to be 1 - 2 m, but 4 m tides have been recorded on one seamount.)

EXAMPLE A normal beamwidth sounder, crystal controlled to give better than +0.1% timing accuracy and with time marks on the depth record, would be classified "3D".

FIDELITY WITH WHICH SCALED SOUNDINGS REPRODUCE SEABED - 2nd REVISION

Ideally, a profile re-constructed from the scaled soundings would reproduce the original echogram exactly; no information would be lost. Unless the seabed is quite smooth, practical problems of man-hours, plotting scale, etc. reduce the "fidelity" of scaling. The classification reflects how closely the ideal has been approached under the existing constraints of seabed roughness and practical considerations.

CATEGORY

- D Soundings scaled at deeps, peaks and inflexion points; seabed smooth between soundings. On the depth profile, straight lines between scale soundings agree with the actual seabed within the tolerance established by the sounding accuracy.
- E Soundings scaled at deeps, peaks and inflexion points; seabed not smooth between soundings. On the depth profile, straight lines drawn between scaled soundings depart from the actual depth by more than the sounding accuracy.
- F Soundings scaled at equal intervals along the track, with a maximum of one deep and one peak scaled between each regular sounding; or soundings scaled at a specified contour interval plus all highs and lows.
- G Soundings scaled at equal intervals along the track.
- H Only spot soundings available.
- Z Sounding selection criteria not specified.

EXAMPLE Soundings scaled at peaks, deeps and inflexion points. But due either to the seabed being very rough, or to constraints of time available or a small plotting scale, the difference between the original echogram and a profile reconstructed from the scaled soundings will exceed the sounding accuracy of  $\pm 0.1\%$  of depth. Classification is "E".

DATA PROCESSING - 2nd REVISION

In compiling large-scale plots of seabed areas of special interest, and in reconciling data from difference sources, it is useful to have the source data available and to know just how the depth measurements, which are in fact time measurements, were converted to true depth. This code consists of a number denoting whether or not the source data is supplied, and whether the sounding velocity used in recording depths is specified, followed by a letter giving the method used in correcting the soundings.

<u>CATEGORY</u>	<u>OBSERVED SOUNDINGS &amp; RECORDING VELOCITY</u>
1	Original or photocopy of echogram supplied. Recording velocity specified.
2	Original or photocopy of echogram supplied. Recording velocity not specified.
3	Listing of original, uncorrected soundings supplied. Recording velocity specified.
4	Listing of original, uncorrected soundings supplied. Recording velocity not specified.
5	Only corrected soundings supplied.
	<u>METHOD OF CORRECTING SOUNDINGS</u>
D	By sounding velocity measurement at the time of the survey, giving a correction of an accuracy that matches the sounding accuracy.
E	By sounding velocity measurement at the time of the survey, giving a correction that is less accurate than the sounding measurement itself.
F	By local sound velocity tables which are an improvement over Matthews Tables.
G	By Matthews Table, or equivalent.
H	Soundings are not corrected.
Z	Correction not specified.

Example If a photocopy of the echogram were supplied with the recording velocity specified, and a listing of soundings corrected by Matthews Tables was also supplied, the classification would be "IG".

Collected Example A systematic survey in which soundings were positioned to better than  $\pm 1$  km (0.5 NM) relative and  $\pm 3$  km ( 2 NM) geographic accuracy; a normal beamwidth crystal controlled sounder was used; soundings were scaled at peaks, deeps and inflexion points but it was not feasible to reproduce the entire echogram within the  $\pm 0.1\%$  depth accuracy; photocopy of the echogram was supplied, sounding recording velocity specified and soundings corrected by Matthews Tables. The classification would be:

(Position)	(Depth)	(Fidelity)	(Data)
2F	3D	E	IG

APPENDIX C1. National Ocean Survey Automated Information System\*

NINTH UNITED NATIONS  
REGIONAL CARTOGRAPHIC CONFERENCE  
FOR ASIA AND THE PACIFIC  
WELLINGTON, NEW ZEALAND  
11-22 FEBRUARY 1980

Paper Submitted by the United States of America

---

\*Prepared by William G. Swisher, Marine Data Systems  
Project, National Ocean Survey, NOS, NOAA, Rockville,  
Maryland 20852.

### Summary

The National Ocean Survey is committed to an effort to automate the processes required to create and maintain nautical charts. This task requires the introduction of automated techniques in three basic areas. These are: data management, interactive graphics, and management reporting.

The National Ocean Survey Automated Information System (NOS/AIS) utilizes some of data processing's latest advancements to perform these functions. An online geographically oriented data base coupled with an array of interactive graphics systems has given cartographers the tools needed to maintain charts in a timely manner.

## Introduction

The National Ocean Survey (NOS) of the National Oceanic and Atmospheric Administration (NOAA) has, as one of its primary missions, the production and maintenance of nautical charts for the navigable waters of the United States and its possessions. This is a continuous effort due to the constant changes caused by natural and human processes. To measure these changes, NOAA has a fleet of ships and aircraft gathering data for charting purposes. Information is also received from other U.S. Government agencies and the private sector. The current base of charting information must be updated to reflect any potential dangers to navigation that are uncovered by the new data.

In theory, new data are collected in the field, and charts are modified to reflect the changes. However, in practice, bottlenecks have developed. Sophisticated data collection techniques using computers, rapid navigation, and digital fathometers have outpaced the ability of the cartographer to utilize all of the new information. As the volume of data increased, NOS found itself in the position of amassing the critical adjustments to charts which were then stored for future use.

To alleviate this problem NOS has developed a set of computer based systems that will speed the application of data to nautical charts. These include:

- Automated data acquisition systems aboard NOAA ships that also accomplish some preprocessing functions.
- Automated processing facilities at the Atlantic and Pacific Marine Centers for verification of data before it is sent to NOS Headquarters.
- A digitizing system to capture graphic information in digital form.
- Flatbed scribe plotters and a laser raster drum plotter to produce negatives for chart printing.

The missing link in this automated chain of processes has been recently developed, under contract, by the Planning Research Corporation. This system, the National Ocean Survey Automated Information System (NOS/AIS), receives data from the Marine Centers, the digitizing subsystem, and outside sources. It stores this data in a readily accessible form and allows retrieval for interactive compilation of charts. The system also produces digital output which can be plotted for use in chart reproduction. Figure 1 shows the relationship of the AIS to other computer based systems in NOS.



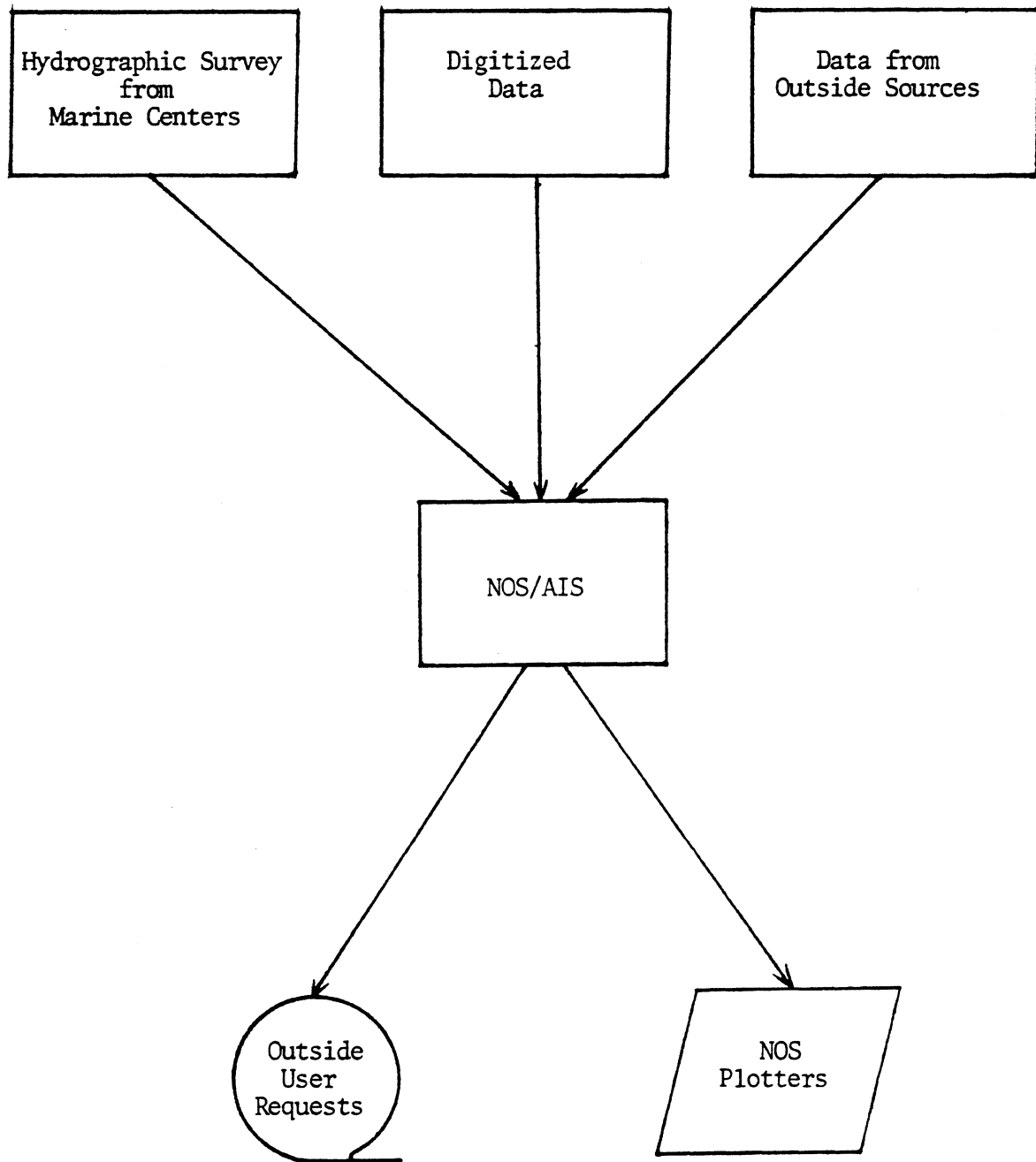

Fig. 1 - Relationship of the AIS to other computer based systems in NOS.

## NOS/AIS

The NOS/AIS is the backbone of the National Ocean Survey's automated nautical charting effort. It performs three critical functions that are necessary for chart construction and maintenance. First, it provides a mechanism for managing the vast amounts of data that are required to create and maintain a complete chart product. Second, it provides the cartographer with a tool that allows the interactive manipulation of cartographic information. Third, it provides the management information necessary to control the charting process. The AIS not only handles these basic functions, it also performs them in a timely manner. An explanation will now be given on how the AIS fulfills these requirements.

### Data Management

NOS is responsible for charting approximately two million square miles of the earth's surface. The amount of data necessary to represent this area is immense and, therefore, requires an effective management tool. Automated data processing provides this tool in the form of an online data base.

In a data base environment all data relevant to an organization's tasks are stored in a central repository. Access to

this data is controlled by a sophisticated set of computer software called a data base management system (DBMS).

The way the data is organized within a data base is very important to the successful operation of the system. An organization must analyze how its data is used and structure the data base accordingly. NOS examined two different approaches to data base organization. The first was based on a chart oriented data base. Since the ultimate output of the system is a chart, it seemed logical to organize the data base by chart product. However, the same cartographic feature will likely appear on multiple charts due to the hierarchy of scales and overlapping coverage. Therefore, in a chart oriented data base, the same feature would be stored once for each chart on which it appeared. This redundant storage of data would greatly increase the size of the data base. It would also require each chart representation of a feature to be modified when a change occurred.

An alternative scheme for organizing the data base solved these problems. By using a geographically oriented data base each feature is stored only once. Accompanying information is used to tell how the data are depicted on the various charts. This technique eliminates redundant storage, which in turn, decreases the size of the data base and prevents conflicting depictions of features within a set of charts.

In this structure a feature is stored according to its geographic position. To make the storage scheme more manage-

able, the earth's surface is subdivided into one degree by one degree squares. Certain types of data that fall within a given degree block are stored together. These are:

- Published traveling features and channels. These features typically extend distances greater than five minutes, and they are currently published on at least one chart. Examples are: pipe lines, cables, and channels.
- Unpublished traveling features and channels. These are the same as above except that they are not currently published on any chart.
- Small scale topographic data. This is published and unpublished topographic data that may appear on charts of smaller scale than 1:100,000.

The data base management system used in the NOS/AIS is named TOTAL. This DBMS allows direct access to master records on disk storage devices. Direct access is important because it is the fastest way to retrieve information from a computer system. Each degree block is defined as a master record to the TOTAL data management system. This allows rapid access to the above types of information.

Near the shoreline, where data is more heavily congested, a further refinement is made to the degree block subdivisions. In these areas a master record represents an area that is five minutes by five minutes square. The types of data that are stored

within each of these blocks are:

- Large scale published features. These are features that are published on charts of scale larger than 1:100,000 and are not traveling features or channels.
- Small scale published features. This category contains published features that appear on small scale charts excluding traveling features and channels. If a feature appears on both small and large scale charts, it is grouped with the small scale data.
- Unpublished features. This group contains all unpublished features except traveling features, channels and small scale topographic data.

A variety of data records have been devised to represent the different types of cartographic features. Usually a group of these records is required to represent one feature. A ship wreck, for example, requires four records to be stored. The first record, called the base data record, holds information about the type of feature and its geographic position. The second record in the sequence is called the compilation fact. It tells which chart entities the feature appears on. The next record describes the position, characteristics and publication status of any nomenclature that accompanies the symbol. The last record in the sequence gives the actual text which appears on the chart, for example, "SUBMERGED WRECK."

That basically describes how the data is organized. Data is to be loaded into the data base in phases. The first area to be loaded is the Gulf of Mexico and will be completed by early 1980. All of the data for a given area is loaded at the same time so cartographers will be able to use the system's full capabilities just as soon as an area is loaded. Other areas will follow the Gulf as the data collection effort is completed, and the entire three billion character data base will be loaded by 1983.

#### AIS Hardware

To store and access three billion characters of data requires a sophisticated computer system. Figure 2 is a diagram of the NOS/AIS hardware configuration.

The central site portion of the system consists of two Univac V76 minicomputers in a master and slave configuration. The data are stored on disk storage units with a 300 million character capacity. There are three high speed tape drives attached to each central site minicomputer. These are used to input new data to the system, output data to the NOS plotters, and for other system functions. The central site is attached to the cartographic work stations by a high speed data link. The work stations will be described in detail later.

#### AIS Software

Having now seen how the data is organized and the hardware components that are available, it would be beneficial to start a

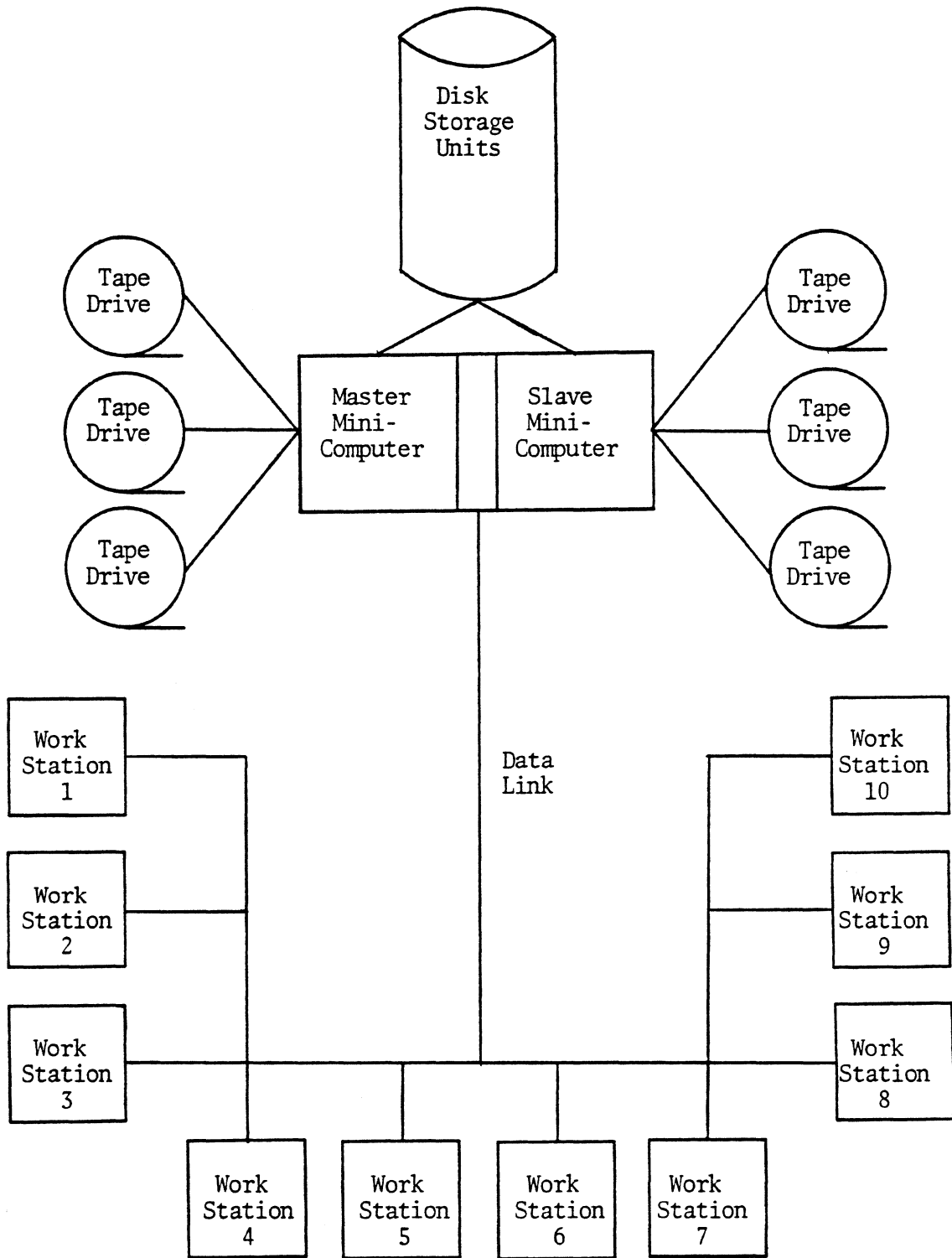

Fig. 2 - NOS/AIS Hardware Configuration

cartographic request through the system to see how everything works. This will also provide an opportunity to describe the computer software that controls the system.

A cartographer initiates the process by submitting a request for data to be sent to one of the cartographic work stations. The request may take many forms. The most frequent requests are for data that lie within a given geographic area or on a given chart. The area can be any polygon with from three to eight sides. Chart and area requests can be qualified to limit unwanted data from being sent to the work station in numerous ways. For example, one can request only published data, only unpublished data, or only a certain type of data like soundings or buoys. The request must also include control type information, for example, a user number for security purposes, a request number, and the number of the work station to which the data is to be sent.

A typical example of a cartographer's use of the system is to apply the information supplied by a new hydrographic survey to the appropriate charts. When a new survey is received at NOS Headquarters it is loaded into the AIS "new data holding file." A cartographer then submits a request for the published data covering an area slightly larger than the survey to be retrieved from the data base.

Once the request is submitted an executive control program schedules the various programs that are needed without operator intervention. The first program edits the request for errors.



The next program makes sure all of the resources needed by the request are available. This mainly involves making sure that the data requested from the data base is not currently being used by another cartographer. In order to preserve integrity in the data base, two requests cannot use the same data at the same time. If all resources are available, the retrieval program then extracts the requested data from the data base and the new data holding file and sends it over the high speed data link to the work station.

When the data arrives at the work station the cartographer may begin the work session. The activities at the work station are a part of the second function of the AIS, interactive graphics, and will be discussed in the next section of the paper. After the cartographer has finished with the data at the work station the new and edited data are sent back to the central site to update the data base. The update program modifies the data base records that were edited at the work station, adds records that were introduced, and archives records that are no longer applicable. Records that are archived from the online data base are written to magnetic tape for long term storage.

The last step of the AIS data management function is to back up those portions of the data base which were modified by the work station edit. All cell blocks that underwent changes are copied to magnetic tape. These tape copies along with a backup copy of the whole data base on disk will allow recovery from a failure of the online data base.

### Interactive Graphics

The second major function of the NOS/AIS is to give the cartographer a tool for applying data in a graphic form. The cartographic user does not really care about data base management systems or retrieval and update programs. What he or she does care about is the chart's graphic image. The user wants to see cartographic symbols, shoreline, and soundings the way they are represented on the chart. He or she is not particularly interested in strings of data base records.

To provide the transition from strings of records to a usable graphic display the AIS has incorporated the latest techniques in interactive graphics. Figure 3 shows the work station hardware that provides this power. At this point it should be pointed out that only two of the full complement of ten work stations have been installed. Experience gained from the use of these prototype work stations will play an important part in the selection of the next eight.

The current work station configuration contains the following hardware:

- One Univac V76 minicomputer to control work station processing.
- Two disk storage units to hold work files and programs.
- One Bendix digitizing table for cartographic reference and input.

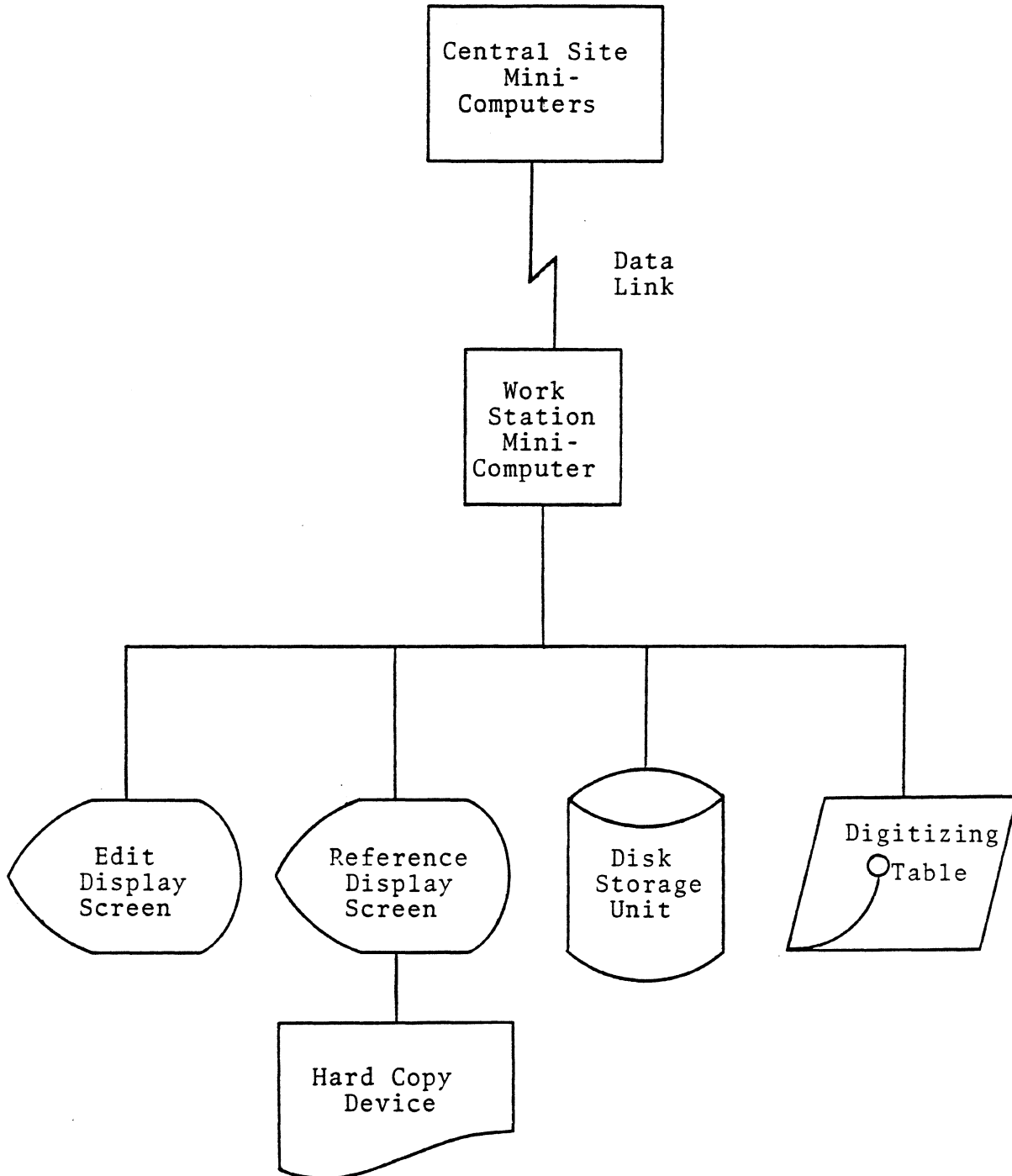

Fig. 3 - Work Station Hardware

- One refresh color graphics display screen for edit.
- One graphics display screen for reference.
- One hard copy device.

These hardware components plus a large group of computer programs allow the cartographer to perform many cartographic functions.

To illustrate some of these functions the hydrographic survey example that was introduced earlier will be continued. The example was left with the cartographic request, including the new survey, having been sent across the data link to the work station. The TOTAL data base management system is used at the work station to control access to the work file.

The cartographer has a scheduled time to use a work station. This time was chosen by the cartographer when the request was initiated. At the preestablished time using the appropriate employee number and security identifier the cartographer will attempt to sign on the system. Unauthorized access, based on these numbers, will cause the work station to disallow further actions, and a message will be sent to the central site operator.

Upon completion of a successful "sign on", the cartographer will place the largest scale chart to which the survey will be applied on the digitizing table. This will be used as a reference to the graphic displayed on the edit screen. The cartographer then selects the area of the chart that will be edited first. Data from the data base that is currently

published on the registered chart will be displayed on the screen in the color green. (The screen is capable of displaying five colors). The cartographer will also ask to see preselected data from the new hydrographic survey. This is the new survey data that has been run through an automated sounding selection program. This program selects soundings that are critical to navigation and removes cluttered soundings so that an appealing graphic representation is given on a chart. These soundings are displayed on the screen in orange. If the cartographer wishes, the entire survey can also be displayed.

The cartographer then applies the soundings from the survey by publishing the appropriate ones. This is done by selecting a sounding on the screen by positioning a cursor under the displayed symbol. When a sounding is found it will blink on the screen. The "publish" button on a keyboard is depressed and the status of that sounding is changed accordingly. In the same manner, soundings from the data base may be changed to an unpublished status for the registered chart.

The survey is applied to the whole chart, and then the next smallest scale chart is registered on the digitizing table. The cartographer now asks for selected soundings. These appear in red and are those that were published on the larger scale chart. Since the level of detail at the larger scale is greater than at the smaller, only those soundings selected at the large scale will be applicable. This process will continue until the survey has been applied to all appropriate charts at the various scales.

The concept of applying data "through the scales" is a great benefit provided by the AIS. In the past, all new data was used at each scale. With the AIS a refined subset is used for each successive scale. This provides a great time savings.

When the cartographer is finished editing the data a "sign off" command is issued. Before the data is sent back to the central site for update the transactions must be checked by an authorized reviewer. The reviewer signs on the work station with a special security identifier. If the chart has been incorrectly compiled, the reviewer may modify the data or have the cartographer sign back on to do so. When the chart is correct, the reviewer signs off for update. The data is then sent back to the central data base for update as was described earlier.

The application of a hydrographic survey is just one example of how the AIS aids in chart compilation. Channels, shore line or any cartographic feature can be added or modified in the same way. A very real benefit is gained by using the AIS to continually maintain charts. Continual maintenance means that when a change to a chart is received at NOS it is immediately applied to the existing base of chart data. In this way, a chart is ready for publication with the most current data at all times.

When a new edition of a chart is to be issued a cartographer will make a request for a chart retrieval to the AIS. The chart will be sent to the work station and the cartographer can manipulate the data to improve the chart's appearance. This might

include the rotation of cartographic symbols, repositioning nomenclature or clearing an area for text. Rotation is accomplished by finding the desired feature and depressing the rotate button until the desired angle is reached. Repositioning of features is handled by using four function buttons which move the feature up, down, left and right. To blank an area of shore line the two points on the line that bound the area are found and unpublished.

With this type of interactive capability the AIS has removed the need for a cartographer to spend time drafting. With manual techniques the cartographer must draw in all of the changes. With the AIS these functions are performed by pushing a button. The cartographer's major effort is in applying cartographic skills, not drafting.

One final example of the power of the AIS must be cited before going on, and that is the creation of a new chart. In this example assume that a smaller scale chart is being created. The cartographer will first add the geographic limits of the chart to the chart information file. Then an area retrieval will be made that encompasses the new chart. When the data arrives at the work station the cartographer will display the data for the larger scale chart and designate it as "selected." This means that the data will be applied to another chart. The system will ask the cartographer what chart is to be the compilation chart, that is, the one which the selected data will be applied to. The cartographer enters the number of the new chart and then

proceeds to publish the appropriate data from the selected chart to the compilation, or new, chart. This technique provides considerable time savings over the manual creation of new charts.

### Management Reports

The final function of the NOS/AIS is to provide management with sufficient information to aid in scheduling, controlling costs, and to aid in the evaluation of the system's performance. Information gathering modules have been incorporated in the AIS software to supply input to the management reporting function. Some of the reports that are available to cartographic management are:

- Chart Job Accounting - This report gives the work station time, system time (retrieval and update), the number of transactions and the cost incurred based on cartographer and reviewer time. The report can be generated for each chart.
- Geographic Area Job Accounting - NOS cartographic staff are broken up into seven teams, each with responsibility for a geographic area. This report gives time, transactions and cost information as above except that it is based on a whole area rather than one chart.
- Reviewer Job Accounting - This gives the same information keyed to a reviewer.
- Outside User Job Accounting - This gives the same information keyed to a request outside of NOS.
- Cartographer Job Accounting - This gives the same information on a given cartographer.



- Work Station Usage - This gives the time the work station was active, number of transactions, and various file sizes of a given work station.
- Data Base Access - This reports the frequency and types of data accessed, number of transactions, and area of data base access.
- New Document Status - This tells which new documents fall on a given chart.
- Chart Status - This reports which charts fall on a given new document. The last two reports are used to help schedule work.
- Chart History - This report tells what new documents have been applied to a chart.

In addition to the above reports there are many others that supply information to systems programmers and the Data Base Manager. All of the reports can be generated on an "as needed" basis.

### Conclusion

The National Ocean Survey is one of the world's leaders in the advancing technology of automated cartography. The NOS/AIS was a pioneering effort in this field, and, as a consequence, many lessons had to be learned along the way. The most valuable information was gained once the system was in place and cartographers started using it. NOS will put this knowledge to use when the next eight work stations are procured. But this will not end the evaluation process that analyzes user needs and implements appropriate solutions. Technology is advancing at a tremendous rate. But the technical advancements are only good if they are put to use. NOS will stay abreast of technology to give its cartographers the tools they need to cope with our dynamic environment.

APPENDIX C2

Brief Comment on the NOS/AIS

by A.C. Hamilton

In addition to reviewing the paper by W.G. Swisher (Appendix C1) one of the authors (Hamilton) visited the Marine Data Systems Project at the U.S. National Ocean Survey office in Rockville; As Capt. Moses, Project Leader, was out of town at the time, Mr. Dale Westbrook, acting Project Leader, convened a briefing session with input from Messrs. Ernie Thomas, Jim Lyall, Robert Kidwell and Lt. Commander Gregory Bass. In addition individual discussions with Lt. Commander Bass and with Mr. Kidwell were held and a complete tour of the Project was arranged.

As the main features of the system are clearly described in Swisher's paper only some very general comments will be made here. There is a fundamental difference in concept between the NOS/AIS project and the system proposed in Chapter 4. In the NOS/AIS concept all the data for all nautical charts will be in one large central data base. Each sounding, each navigational aid, each segment of shoreline, each shoal, each name, etc. is a *feature*. This, in effect, makes it an "all or nothing" system.

From such a brief, superficial look it would be presumptuous to comment on the suitability of the AIS for NOS, however a brief comment on the applicability of a similar approach for handling Arctic data is warranted. Briefly the comment is that this approach is not recommended for the management of Arctic hydrography data at this time. After the system has been operational for some time, say two years, its applicability for C.H.S. should be reviewed again.

There are, however, several items which do appear to warrant further study, namely:

1. The use of cells of 1°x1° for open water data and 5'x5' for data that includes at least one segment of shoreline.
2. The procedure of selecting soundings for the largest scale chart first and "flagging" them for use if or when selections are made for smaller scale charts.
3. The use of accuracy factors.
4. A computer-assisted sounding selection procedure.
5. A computer-assisted contouring procedure.
6. Use of a sub-routine for tidal corrections.

APPENDIX D

Preliminary Agenda and Participation

for a Workshop on the Management of Arctic Hydrography Data

Objective: To review the management of Arctic hydrography data and if change in the approach is necessary to make recommendations for the transition.

SESSION I - Orientation and background.

DAY 1: Orientation and discussion of the objective

- Ewing
- McPhee
- Anderson

Historical Review

- D.W. Thomson (?)
- Panel of old-timers

(Evening - Reception and Dinner)

SESSION II - Arctic data and its uses.

DAY 2: Review of the volume, sources, quality and status (published, in progress, etc.) of the data.

Presentations by participants: prepared prior to the workshop.  
Other presentations (if necessary)

Election of a steering committee and a Workshop Coordinator (from the participants).

DAY 3: Uses for C.H.S. Arctic Data.

- Charts - M.O.T. representative
- D.N.D. representative
  - D.P.W. representative

Natural Resources map series - A marine geologist or geophysicist

Other uses - Earth Physics Branch

- Canadian Petroleum Association

Discussion and draft of report on Session II.

SESSION III - Data handling technology.

DAY 4, 5: Modern concepts in data management.

- Representative from Bell Northern Research
- Representative from the School of Library and Information Science, U.W.O.

- others?

Review of commercially available data base managers: System 2000, TOTAL, IMS?

- What they can and what they can't do.

Discussion and draft of report on Session III

SESSION IV - Digitally-oriented systems with graphic phases.

DAY 6, 7, 8

and 9 : Progress reports on relevant systems: Volume, costs, development methods, acceptance by staff, acceptance by others (if relevant).

- Canadian Geographic Information System. D.O.E.

- Topographic Survey System. D.E.M.R. (including tour)

- The National Gravity Data System. (including tour)

- The Automated Information System, N.O.S.

- Others?

- Discussion and draft of report on Session IV.

SESSION V - Managing C.H.S. data.

DAY 10, 11: Review of present methods

Discussion of alternatives

Synthesis of input and preliminary draft of report.

DAY 12, 13: Status reports on supporting files

- horizontal control

- vertical control

- tidal data

- names

- magnetics

- Discussion and draft of report on Session V.

DAY 14: Review drafts of reports from all sessions, develop concensus, draft conclusions and recommendations and assign responsibilities for preparing final draft of the report.

Tentative Participation List

- 3 hydrographers assigned to the Arctic region
- 3 cartographers assigned to work on Arctic data
- 1 nautical geodesist
- 1 tidal specialist
- 1 geodesist (from G.S.C.)
- 1 gravimetrist (from E.P.B.)
- 4 hydrographers or cartographers (1 from each regional office)
- 1 hydrographer from H.Q. (policy & planning)
- 1 hydrographer/geoscientist - Bathymetric mapping