

THE EXPECTED IMPACT OF THE ELECTRONIC CHART ON THE CANADIAN HYDROGRAPHIC SERVICE

**A. C. HAMILTON
B. G. NICKERSON
S. E. MASRY**

March 1984



**TECHNICAL REPORT
NO. 106**

PREFACE

In order to make our extensive series of technical reports more readily available, we have scanned the old master copies and produced electronic versions in Portable Document Format. The quality of the images varies depending on the quality of the originals. The images have not been converted to searchable text.

THE EXPECTED IMPACT
OF THE ELECTRONIC CHART
ON THE CANADIAN HYDROGRAPHIC SERVICE

by

Angus C. Hamilton
Bradford G. Nickerson
Salem E. Masry

Department of Surveying Engineering
University of New Brunswick
P.O. Box 4400
Fredericton, N.B.
Canada
E3B 5A3

March 1984
Reprinted April 1989

FOREWORD AND ACKNOWLEDGEMENTS

This report has been prepared under DSS contract 08SC.FP901-3-R507 to Universal Systems Ltd. of Fredericton, N.B. The project officer was Mr. R.M. Eaton of the Atlantic Region Canadian Hydrographic Service, and he along with Mr. N.M. Anderson and Mr. T. Evangeletos of the Canadian Hydrographic Service Headquarters, Ottawa, defined the terms of reference and suggested several of the sources of background information.

The authors gratefully acknowledge the unstinting cooperation of everyone who was asked for information for this study, whether by telephone, by letter, or by personal visit.

We are particularly indebted to Mr. Robert Beaton of the Hydrographic/Topographic Center, Defense Mapping Agency, Washington, D.C., U.S.A. and his staff for giving us a comprehensive briefing on their activities in the field.

Mr. K. Iwasa and his colleagues of the Japanese Hydrographic Department were both hospitable and helpful. The authors are particularly indebted to Mr. K. Yashima for preparing a short report (section 3.4) on the evolution of the electronic chart concept in Japan.

A preliminary version of this report was given limited circulation in August 1983 with a request for comments. The authors wish to thank all those, especially the manufacturers, who provided additional information.

The most significant differences between this final edition and the preliminary version are found in Chapter 3; in this chapter Table 3.1 has been restructured and updated, section 3.4 (see above) has been added, and some other sections have been revised. Also, in the Introduction, the term "interactive navigation system" has been introduced and a more precise definition of "electronic chart" has been adopted.

EXECUTIVE SUMMARY

The major impact that we expect the electronic chart to have on the Canadian Hydrographic Service is that its principle product, the paper nautical chart, which has been at centre stage since its inception several centuries ago, will very soon be relegated to the role of understudy; the electronic chart will be "where the action is" and the paper chart will be in a chart folio that is rarely opened.

In the course of this study, many variants of interactive navigation systems incorporating an electronic chart display were found to be either in service or undergoing sea trials; a summary of the more significant parameters for several of these systems is presented in Table 3.1 (page 22). For one of these systems the manufacturer is undertaking to provide and update the data base; for all the others, the primary responsibility for the data base is being left to the customer. In any event, several versions of unofficial, ad hoc, electronic chart data bases are being created and it is certain that (wherever an official version is not available) countless unofficial versions will be appearing soon.

Our most significant conclusion is that a major breakthrough in marine navigation is occurring and its success is inevitable. This is because, for the first time since high technology began producing aids such as the gyrocompass, radar, and LORAN-C for the mariner, rather than adding to his workload these interactive navigation systems relieve him of the tedious part of his duties and aid him with real-time information on the most important part--navigating his ship safely.

Given that the widespread use of these systems will occur in the near

future, it follows that the day-to-day use of the electronic chart will surpass that of the paper chart. This leads to the conclusion that the Canadian Hydrographic Service should accept without delay the responsibility for providing up-to-date electronic charts. If it fails to do this, the intent of the Canadian Shipping Act Regulation requiring all ships to have correct up-to-date Canadian charts on board will be thwarted. It will be thwarted because, once a mariner becomes accustomed to a video display it is highly probable that he will continue to use it with some ad hoc unofficial version of the electronic chart data base. That is, the mariner will have paper nautical charts on board simply to comply with the law and not because he intends to use them. The "bottom line" is that the paper chart will not be used to its full potential, hence its value as a navigation tool will be degraded and the relevance and status of the Hydrographic Service itself will be diminished accordingly.

To forestall such an eventuality it is recommended that, as the first step in accepting the responsibility for the production of the electronic chart data base, the CHS should undertake an evaluation project as soon as possible with the objective of developing criteria and specifications for the electronic chart data base.

Based on our findings about the content of the existing commercial data bases, we conclude that initially the electronic chart data base should be created and maintained as a separate entity rather than as a subset of the digital data base being compiled for paper nautical charts.

It is also concluded that an automated system for Notices to Mariners and related publications will be a necessary development to effectively keep the electronic chart data base up to date. It is recommended that planning for this should begin at once.

Our final conclusion is that the CHS should push vigorously for international electronic charting standards to be developed and adopted before massive investments are made by industries and by national hydrographic agencies.

TABLE OF CONTENTS

	<u>Page</u>
Foreword and Acknowledgements	ii
Executive Summary	iii
Table of Contents	vi
List of Figures and List of Tables	vii
Glossary of Terms	viii
1. Introduction	1
2. Chart Production	5
2.1 Canadian Hydrographic Service	5
2.2 National Ocean Service	9
2.3 Defense Mapping Agency	12
2.4 Private Enterprise	13
2.5 Long-Term Scenario	15
3. Interactive Navigation Systems	21
3.1 A Review of Some Existing Systems	21
3.1.1 The VIEWNAV System	24
3.1.2 Sperry Marine CAS II system	26
3.1.3 HICANS and COMDAC	28
3.1.4 TI 8000 Integrated Marine System	33
3.1.5 Furuno GD-200, GD-170 and RS-1000 (Navguide)	33
3.1.6 JRC Color Plotter	35
3.1.7 Tokyo Keiki (ANCDS)	37
3.2 Navigation in Icy Waters	37
3.2.1 Compiling a "Radar Features" Data Base	40
3.2.2 ISR: Instrument Sailing Rules	42
3.3 Impact on the Canadian Hydrographic Service	42
3.4 Statement From the Hydrographic Department in Japan	49
4. Keeping Charts Up to Date	50
4.1 The Responsibilities for Chart Updating and the Sources of Data for Doing So	50
4.2 The Production of Notices to Mariners in Canada	54
4.3 Status Report on Automation of Notice to Mariners by DMA	57
4.4 Rationale for the Transition to Automated Procedures for Canadian Notices to Mariners	61
4.5 Updating for the Electronic Chart	65
5. Standardization	68
6. Findings, Conclusions, Recommendations and Impact Statement	74
Bibliography	80
List of Contacts	81
APPENDIX I	
"The Electronic Chart" by R.M. Eaton, N.M. Anderson and T.V. Evangelatos, a paper presented at the CHS Centennial Conference, Ottawa, April, 1983	84
APPENDIX II	
DMA Automated Notice to Mariners Communications Users' Manual (abridged) April, 1983	101

LIST OF FIGURES

	<u>Page</u>
Figure 2.1 Computer Assisted CHS Marine Chart Production System	6
Figure 2.2 NOS Automated Information System (AIS)	10
Figure 2.3 Evolution of Marine Chart Use	16
Figure 2.4 The Qualified Data Base Approach	18
Figure 3.1 Sperry CAS II System	27
Figure 3.2 The HICANS System	29
Figure 3.3 COMDAC Block Diagram	31
Figure 3.4 COMDAC Turnpoint and Precision Anchoring Graphics Display	31
Figure 3.5 JRC NWU-50A Colour Plotter	36
Figure 3.6 The ANCDS Console	38
Figure 3.7 Electronic Chart Display Resolution	45
Figure 3.8 Production System for First Generation of the Electronic Chart Data Base	48
Figure 4.1 Notices to Shipping (NOTSHIPS)	53
Figure 4.2 The Existing Canadian Notices to Mariners System	55
Figure 4.3 Proposed Automated Canadian Notices to Mariners System	66
Figure 5.1 Present CHS Chart Buoy Symbols	70

LIST OF TABLES

Table 3.1 Status of Some Systems With Which Electronic Chart Data Can be Used.	22
Table 3.2 Chart Digitizer Buffers for the COMDAC System	32
Table 4.1 Information for Mariners in Canadian Waters	51
Table 5.1 Examples of Symbols Used for Nav aids by Interactive Navigation Systems	69

GLOSSARY OF TERMS

ACDDS	Advanced Cartographic Data Digitizing System for digitization and interactive editing of graphic source materials.
AIS	Automated Information System of the National Ocean Survey.
ANCDS	Automatic Navigation Control and Display System, designed and built by Tokyo Keiki Ltd. for the Japanese Maritime Safety Agency, as an ocean navigation system with automatic ship steering.
ANMS	Automated Notice of Mariners System, an automated system for the computerized typesetting of the Weekly Notice to Mariners and periodic Summary of Corrections publications at the DMAHTC.
ARINC	Aeronautical Radio Incorporated, a publisher of aeronautical literature, and an airline industry-sponsored think-tank.
ARPA	Automatic Radar Plotting Aid. Other ship can be tracked automatically by operator identification of appropriate radar targets.
Bit	One binary digit (1 or 0).
Byte	Eight bits--1 alphanumeric character expressed in binary notation.
CAS II	Collision Avoidance System, manufactured and marketed by Sperry Corporation, primarily designed to track radar targets and provide collision avoidance data on them.
CCG	Canadian Coast Guard.
CHS	Canadian Hydrographic Service.
Colour video navigation plotter	- see video navigation plotter.
COMDAC	Command, Display and Control system, made by Sperry Systems Management to solve problems in the areas of navigation, manoeuvring, etc.
CRT	Cathode Ray Tube (similar to a TV tube).
DMA	Defense Mapping Agency of the U.S. Department of Defense.
DMAHTC	Defense Mapping Agency Hydrographic/Topographic Center of the U.S. Department of Defense.
EBCDIC	(IBM) Extended Binary Coded Decimal Interchange Code for data encoding.

Electronic chart - A CRT (video) display on which a ship's own position is shown along with selected chart data; the display may include destination, way points, course, and track made good, as well as radar and other data of particular interest to the navigator or the master of a vessel. It is implicit that an electronic chart is an ephemeral, dynamic entity that ceases to exist when the CRT is turned off.

Electronic chart data base (ECDB) - A selection of nautical chart data in digital format for use in the electronic chart.

EPROM Erasable Programmable Read-Only Memory (for the CAS II channel navigation option).

Furuno Furuno Electric Co. Ltd., a Japanese electronics manufacturer.

GOMADS Graphic On-line Manipulation and Display System. That part of the CHS automated cartography system in which the interactive editing and compilation is done.

GPS Global Positioning System. A network of satellites planned by the United States military to serve as navigation aids anywhere in the world at any hour of the day.

HICANS High Speed Collision Avoidance and Navigation System, made by Sperry Corporation.

IALA International Association of Lighthouse Authorities.

IFR Instrument Flight Rules (for aircraft).

IHO International Hydrographic Organization.

IMO International Maritime Organization.

INMARSAT Satellite communications system, intended for marine users.

Integrated bridge system - A combination of the components of the interactive navigation system and many other sensors, interfaces, and controllers so that functions such as steering the ship can be automated.

Interactive navigation system - Video navigation plotters with associated software and data base along with linkages and interfaces to the sensors, such as LORAN-C, speed log, gyro, radar, etc., that provide inputs to the electronic chart.

ISR Instrument sailing rules.

JRC Japan Radio Co., Ltd.

KByte kilobyte: one thousand and twenty-four 8-bit computer words.

LORAN-C Long Range Navigation. A hyperbolic long wave navigation aid maintained in North America by the Canadian and U.S. Coast Guards.

MByte megabyte: one thousand kilobytes.

N/M Notices to Mariners (Canadian) or Notice to Mariners (U.S.A.). A formal, regular, national mailout of permanent amendments to charts and navigation publications. In Canada, some 14,400 Notices are mailed each week.

nmiles Nautical miles.

NOS National Ocean Service of the National Oceanic and Atmospheric Administration, Rockville, MD, U.S.A.

NOS/AIS National Ocean Service/Automated Information System, a computer based system designed to provide on-line disk storage for the features of nautical charts published by the NOS.

NOTSHIPS Notices to Shipping. A broadcast and mailout system for temporary notices to mariners about items relevant to a major port.

NTX Interchange. Designation for the file into which digitized data is collected and stored in the CHS automated cartography system.

pixel Picture element. A CRT display is made up of pixels; there may be 400 x 400 pixels, or 945 x 945, etc.

PPI Plan Position Indicator. A CRT display of radar echoes.

QDB Qualified data base.

RADAR Radio Aid for Direction and Ranging.

Shoal line - A specific depth contour that is critical for a certain class of ships; for example, the three fathom depth contour may be designated as a shoal line for coastal shipping.

USCG United States Coast Guard.

VIEWNAV Trade name for an interactive navigation system developed by Navigation Sciences, Inc., Washington, D.C., U.S.A. It is intended primarily for shipping channel and harbour navigation.

Video navigation plotter - A CRT on which own ship's position and selected electronic chart data, track data, etc., can be displayed.

VOR/DME VHF Omni-Range/Distance Measuring Equipment.

WMEC Medium endurance cutters of the U.S. Coast Guard outfitted with COMDAC systems.

1. INTRODUCTION

In June 1982 the concept of the electronic chart and some of the implications of its advent were discussed at a three-day workshop held on the campus of the University of New Brunswick. There was consensus that

the evolution of the electronic chart is inevitable, and the only uncertainty is in the tempo of this evolution and of the specific ways in which it will evolve.

and that

the CHS should be moving cautiously but steadily in the development of the electronic chart.

A report on the workshop, entitled "The Electronic Chart", was prepared by Angus Hamilton and Bradford Nickerson; this report was submitted to the Canadian Hydrographic Service (CHS) and subsequently reproduced by the Department of Surveying Engineering at the University of New Brunswick as Technical Report No. 102.

One year later, it is clear that the workshop was conservative in its estimate of the tempo at which the electronic chart would evolve. If the workshop were to be reconvened this year (1983) there is no doubt that the consensus would be revised from "the CHS should move cautiously but steadily in the development of the electronic chart" to "the CHS should move as quickly as possible on the development of the electronic chart".

As the need for a clear, concise definition of the term "electronic chart" has become urgent, the authors have addressed this need by posing some questions: What is an electronic chart? Is it hardware and software? Is it one or more digital data bases? Is it a combination of hardware, software, and data bases? Or is it something other than any of the above?

Before answering these questions, we critiqued traditional navigational terminology very carefully. In classical navigation there was

hardware but it was quite simple--a plotting table, draughtman's compass and ruler, almanac, and logarithmic tables; there were the classical sensors--magnetic compass, sextant, and ship's speed log. There was, of course, the paper nautical chart. On close inspection, it is seen to have two distinct identities:

- (i) It has its virginal on-the-shelf form in which it is simply a data base on paper.
- (ii) It has its operational, plotting table form whereby it is the medium on which the inputs to the navigation process are synthesized and on which a permanent record of track made good, way points passed, etc., are logged.

In effect, this second form is the interface between the (human) navigator and the combination of hardware, data bases, and other inputs to the navigation process.

Now, let us look at the new navigation. There is the hardware, namely the video navigation plotter and its built-in software as well as the linkages and interfaces to the sensors; in this report, "integrated navigation system" is the umbrella term used to include all of this hardware and its associated software.

Then there is:

- (i) The electronic chart data base--the analogue of the on-the-shelf paper chart.
- (ii) The synthesis of the electronic chart data base with own ship's position, ship's speed and course, radar returns, and other inputs, and the production of a track-made-good display and log--the analogue of the operational plotting table mode of the paper chart.

In effect, this synthesis serves as the interface between the (human)

navigator and the combination of hardware, software, data bases, and other inputs to the navigation process that makes interactive navigation possible.

Drawing on the analogy with the second, i.e., the operational, identity of the paper chart, we now propose a definition for the electronic chart.

An electronic chart is a CRT (video) display on which a ship's own position is shown along with selected chart data; the display may include destination, way points, intended track, and track made good, as well as radar and other data of particular interest to the navigator or the master of a vessel. It is implicit that an electronic chart is an intangible, dynamic entity that ceases to exist when the CRT is turned off.

In this study, the state-of-the-art of paper chart production and the progress of computer-assisted methods is documented. Similarly, a review of operational video navigation plotters, collision avoidance systems, and integrated bridge systems is documented. As a generic umbrella term that covers all of the systems used to display navigation data for the mariner, the authors suggest interactive navigation systems. Some of these systems show only own ship's position and a small amount of chart data; others have radar adaptors such that either the radar echoes or Automatic Radar Plotting Aid (ARPA) data can be overlaid on the video display along with ship's position and chart data. At the upper end of the spectrum are the integrated bridge systems that have linkages for automatic steering as well as displaying all or any selection of the above-described data.

As a point of departure for the study, the Charts and Publications Regulations of the Canada Shipping Act were reviewed and it was found that

4(1) Every ship shall have on board, in respect of each to be navigated by the ship, at least...(a) the latest edition of the Canadian Hydrographic Service Charts.

7 Every ship shall ensure that any chart or publication... on board the ship is, before being used in the navigation of the ship, corrected up-to-date from information that may affect the safe navigation of the ship and that is contained in a Notice to Mariners.

These regulations are set down to ensure the safe navigation of ships in Canadian waters. Similarly, in reviewing the mandate of the Canadian Hydrographic Service it was found, in the Second Edition [1979] of "The Role of the Canadian Hydrographic Service" that the CHS

...must carry out the necessary hydrographic surveys and publish, maintain, distribute the nautical charts, sailing directions and tide tables which are required to permit safe navigation by all users of the navigable waters of Canada. Within this objective emphasis must be given to the major commercial routes...

The present nautical chart production systems of the CHS, the U.S. National Ocean Service, and the U.S. Defense Mapping Agency are reviewed. Several video navigation plotters and integrated bridge systems are listed and described briefly. The Notices to Mariners system for keeping charts up to date is also reviewed. A brief look is taken at standardization of electronic chart symbology.

This report establishes that electronic chart data bases are being digitized from existing paper charts by individual manufacturers or shipping companies to suit their own particular hardware requirements. Finally, some recommendations for the CHS are made on how to approach this dawning age of electronic charts.

2. CHART PRODUCTION

Production of nautical charts is primarily a government responsibility. The Canadian Hydrographic Service (CHS) is charged with producing and maintaining nautical charts for all Canadian waters. The National Ocean Service (NOS) (formerly the National Ocean Survey) of the National Oceanic and Atmospheric Administration (NOAA) of the United States (U.S.) is responsible for production of nautical charts for the Great Lakes, U.S. coastal waters and U.S. possessions. Worldwide charts (excepting U.S. waters) are provided by the Defense Mapping Agency (DMA) for the U.S. Navy and for other users. Current and immediately planned production processes for these three agencies are reviewed and the data base production procedures being followed by two of the firms that are marketing interactive navigation systems are summarized.

2.1 Canadian Hydrographic Service

Approximately 1500 nautical charts are presently produced by the CHS. Responsibility for their production and revision schedules presently lies with the "regions", i.e., Atlantic (Dartmouth, Nova Scotia), Quebec (Quebec City), Central (Burlington, Ontario), and Pacific (Sidney, British Columbia). The Ottawa office of the CHS is responsible for standards in surveying and chart production, chart scheming, Notices to Mariners, translation services, special projects, chart production, system development and software maintenance, and certain overload requirements from the regions.

Present chart production is depicted in Figure 2.1. It can be seen that the process is a mixture of both manual and computer assisted

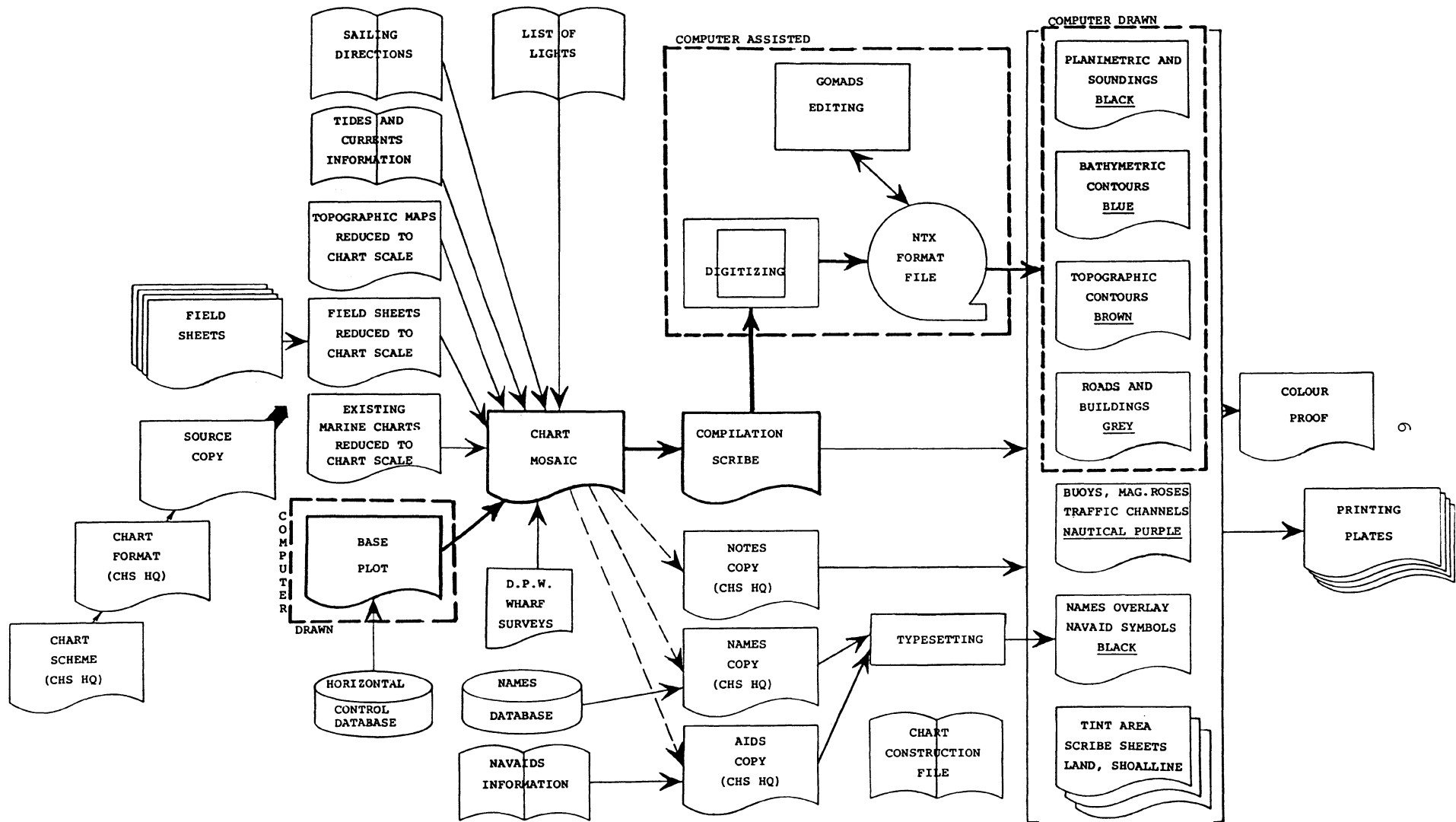

Figure 2.1 Computer Assisted CHS Marine Chart Production System

techniques. Although good progress has been made towards automating the procedure, manual processes still predominate. Significant time savings occur with computer generation of the contour overlays; however as most charts are not presently in digital form, these overlays must first be digitized and edited. This process consumes almost as much time as the manual drafting process would have taken. Once in digital form, the editing and revision process becomes much easier. The digital files are simply loaded into the computer and edited, using the GOMADS software in conjunction with the TEKTRONIX 4014 graphics terminal. This and other aspects of computer assisted chart production at the CHS have been fully described by T. Evangelatos.

Although, as described above, good progress has been made in computer assisted chart production, there are two important data sets for which computer assisted procedures are not yet available: names, and navigation aids. Both of these data sets are plotted manually from the "names copy" and "aids copy" provided by CHS headquarters in Ottawa. As navigation aids is perhaps the most important data set in the electronic chart data base, it is evident that the existing digital data base for the paper chart is not complete enough to serve as a "parent" for the electronic chart data base.

During informal discussions with cartographic production staff at the Bedford Institute of Oceanography, it became apparent that a minimum of two years normally elapses from the time it is decided to produce (or revise) a certain chart until the new (or revised) chart is available for distribution. This lengthy and costly process is not initiated until there are many corrections and additions to be made to a chart; this is because of the "mass production" economics of the multi-colour lithographic

printing press. In effect, the printing press technology has forced a cumbersome and inefficient mode of information management on the marine community. With the evolution of the electronic chart, this dictatorship of the printing press can be broken.

Relatively few charts are now available in digital form (i.e., the interchange (NTX) format files presently used as standard format by the CHS for storing and distributing the digitized chart data). Of the 400 Atlantic Canada charts under the Atlantic region's jurisdiction, 8 (as of 28 July 1983) are now in digital (NTX) form. On average, each chart in NTX format consumes approximately 2 MBytes of storage. Of the 14 new charts scheduled for completion in 1983, 8 were to be available in NTX format. By the end of 1983, only 16 of the 400 Atlantic coast charts (4%) were in NTX format. At this rate, all 400 charts in the Atlantic region will not be in digital form until 2005.

In summary, from this rather brief review of CHS computer assisted chart production, we found:

- (i) The digital data base for paper chart production does not include geographic names or navigation aids (except a few that are permanent landmarks).
- (ii) The elapsed time for production or revision of any one chart is in excess of two years.
- (iii) At the present rate of production a digital data base for all 400 of the Atlantic coast charts will not be complete until the year 2005.

From these findings we conclude that *the digital data base for the paper chart is not now and may never be adequate as a "parent" for the electronic chart data base.*

2.2 National Ocean Service (NOS)

Approximately 987 charts fall under the jurisdiction of the NOS. Besides the manual production process, NOS has been implementing (since approximately 1970) the Automated Information System (AIS) as described by Bass in a paper presented at the 20th Annual Canadian Hydrographic Conference, held in Burlington, Ontario, in April 1981. The NOS/AIS revolves around the AIS data base. This data base is a repository of all information on the NOS nautical charts. Organization of the data base by features referenced to geographic coordinates means that changing chart scales or boundaries is relatively easily done. Most data is encoded in "degree blocks", i.e., all coordinates are with respect to the latitude/longitude graticule intersection at the lower left of a degree block. Larger scale charts are referenced to a 5 minute by 5 minute block. Data is not organized by chart, as in the CHS system. It is stored in a central disk storage facility consisting of five, 300 MByte disk drives. These provide immediate access to all data published on the NOS charts and presently available on the AIS. Figure 2.2 is a stylized block diagram of the NOS/AIS.

Two cartographic work stations are presently used to digitize, edit, and update the data base. Each work station consists of

- (a) a Sperry Univac V76 computer with 160 KBytes main memory;
- (b) a Sanders 4 colour vector refresh edit graphics terminal;
- (c) a monochrome storage type graphics terminal;
- (d) two 58 MByte and one 300 MByte disk drives;
- (e) a digitizing table and graphic hardcopy device.

Six more work stations are due to be delivered in March 1984. These work stations will each include a Sperry Univac V77 computer, a RAMTEK RM 9400

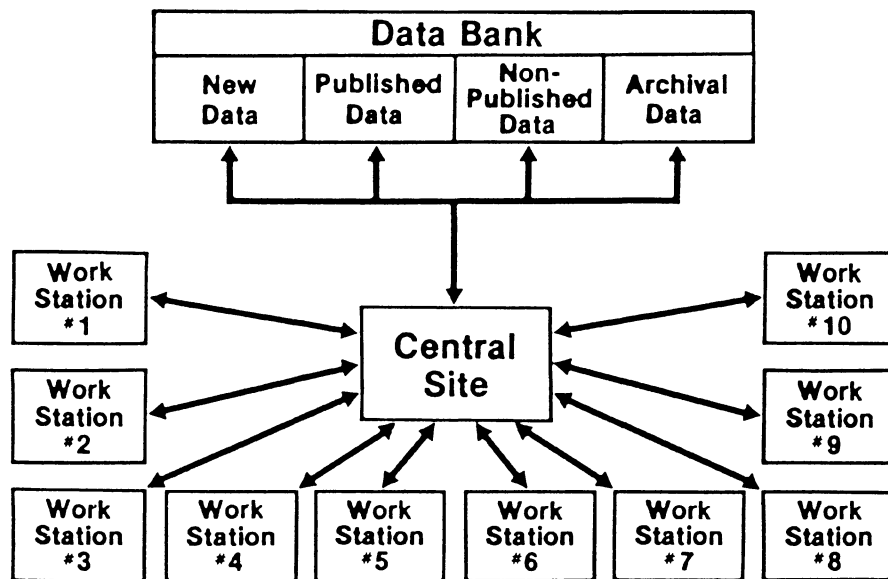

Figure 2.2 NOS Automated Information System (AIS)

colour graphics terminal and two 300 MByte disk drives. With this added hardware, it is anticipated that most of the areas presently in the data base will be kept updated on a daily basis.

The NOS/AIS data structure incorporates four basic types of data; i.e., new, published, unpublished, and archival. Only the published data will appear on printed versions of the chart. New data is that which is eligible for publication, but has not yet been approved and checked. Unpublished data are features useful and available for publication, but for cartographic purposes are not presently included (e.g., segments of a contour deleted to make room for the contour label). Unpublished data are available online to be used in case some new data require restructuring an area of the data base. Archival data have been determined to be no longer valid for charting purposes, and are permanently removed from disk storage onto backup tape. This cartographically oriented data structure plus the capability to edit within any geographic window makes the NOA/AIS workstation a powerful and very flexible tool.

Presently, approximately 30% of the NOS charts have been compiled into the AIS. These data are primarily in the Gulf of Mexico and south Atlantic coast areas. The amount of data for any particular area depends on the scale of chart which was digitized, and the amount of topographic contours included. Areas which have many buoys and other nav aids do not have any topographic contours as they are not needed for navigation. Data representing one harbour area typically requires less than 4 MBytes of storage. All NOS charts are scheduled to be in the AIS by approximately 1988. It has been noted by Greg Bass of NOS that having the data in the data base is only the first step; the cleaning of the data to ensure that everything was digitized properly is also a very important step.

Once the NOS charts are in the AIS data base, it is a simple task to retrieve the features required for the electronic chart data base, but it is not a simple task to generalize features, such as coastline and bathymetric contours, for this data base.

2.3 Defense Mapping Agency

The Defense Mapping Agency Hydrographic/Topographic Center (DMAHTC) presently publishes many thousands of nautical charts for areas all over the world. In addition, they must respond to specific Department of Defense projects requiring special-purpose nautical chart products.

As explained by Sinclair in the proceedings of the 20th Annual Canadian Hydrographic Conference held in Burlington, Ontario, in April 1981, a SCI TEX Response 250 Raster Processing System based on HP1000 Series E minicomputers is used. This system includes:

- (1) A SCI TEX Laser Scanner capable of recovering 12 different colours per scan at a resolution of up to 40 points per mm.
- (2) Four SCI TEX Response 250 full colour edit stations for real time cleaning up of the pixel colours, raster to vector conversion, and generation of standard symbology.

Output from this system is a tape of vectorized (line and point) data for each of the different colour overlays.

The Advanced Cartographic Data Digitizing System (ACDDS) produces the plot tape for driving the automated plotting system. The ACDDS is based on a Data General S130 Eclipse minicomputer with 1 MByte of main memory. Each of the present four work stations has

- (a) a NOVA/4 minicomputer with 64 KBytes of main memory;
- (b) an ALTEK digitizer;

(c) a TEKTRONIX 4014 display screen for plotting and editing the cartographic data;

(d) a NOVA alphanumeric display video terminal.

These work stations are primarily used for digitization and interactive editing of digital files to be used for final chart production. After the files are edited, the main computer generates the plot files to be used for plotting the colour separation negatives.

No single comprehensive data base has been designed for use by DMAHTC in the production of nautical charts. Each specific project has its own needs and the electronic data requirements for each are so varied, it is felt that no one cost effective data base design, such as the NOS/AIS, would meet the DMA's needs.

2.4 Private Enterprise

Two private sources of electronic chart data bases have recently become available. Both Navigation Sciences, Inc. (NSI) of Bethesda, MD and Sperry Marine Systems of Charlottesville, VA are digitizing nautical charts for use in their own interactive navigation systems.

NSI digitizes (primarily) NOS charts depicting the busiest harbours and intercoastal waterways (e.g., Tampa Bay, Baltimore Harbour and the C & D Canal, New York Harbour). The following types of information are captured in different overlays:

- (a) shoreline
- (b) 18-foot shoal line (depth contour)
- (c) buoys and lights
- (d) obvious topographic navigational aids.

Data is referenced to 1 nmile by 1 nmile graticule intersections. A number

of these "1 mile pages" are used to compile a regional chart (typically covering a single harbour or harbour entrance). Typical regional charts use 2 MBytes of storage and are compiled from several NOS paper charts. Electronic chart data bases supplied by NSI are used by the VIEWNAV system (see Chapter 3) which provides a 7-colour display of the electronic chart. Data base correction and updating will also be provided by NSI as a service. Information for chart corrections is obtained from the U.S. Coast Guard Local Notice to Mariners and the Defense Mapping Agency Notice to Mariners publications.

Sperry Marine digitizes information for use in their CAS II collision avoidance system with the channel navigation option (see Chapter 3). Data is digitized and kept in a data base for later updating (if required). The data which is entered is very much dependent on what the individual customer requires. Revisions or updates are only carried out at the customer's request.

These data bases produced by private companies for their own interactive navigation systems are invariably system specific; needless to say, this leads to much duplication of effort. Questions of data integrity also arise. Does private industry assume legal responsibility for the correctness of the data bases they provide? The answer seems to be no. Sperry Marine puts the onus squarely on the customer to provide the positions of navigation aids. Similarly, Navigation Sciences, Inc. does not intend to assume legal responsibility for the correctness of chart data provided to customers.

2.5 Long-Term Scenario

In "The Electronic Chart", a paper presented at the Canadian Hydrographic Centennial Conference in Ottawa in April, 1983 (see Appendix I), messrs. Eaton, Anderson and Evangelatos did some day-dreaming about navigation as it might be in the year 2000. Their primary purpose was to alert hydrographers to the fact that the technological revolution is impacting on all aspects of hydrography and marine navigation. In this section the focus is on the probable future transition from complete reliance on paper charts to complete reliance on electronic charts.

Two distinct requirements for nautical charts are emerging. They are:

- (1) The standard paper nautical chart with all of its detailed soundings, contouring and topographic features will certainly be required as a navigation tool as long as there are any ships not equipped with interactive navigation systems.
- (2) A stripped down, or decluttered, version of the nautical chart in electronic form with separately available files of simplified coastline, simplified shoal line, aids to navigation (e.g., buoys, lights and obvious topographic features, shipping channel and anchorage area designations), and navigational hazards (e.g., oil rigs, shipwrecks).

Figure 2.3 depicts the past and possible future evolution of marine charts. As long as there is a need for a nautical chart on paper, the computer assisted approach with a chart oriented data base is adequate. Whenever the printing press is used to print many copies of the present day multicolour nautical chart, significant delays can be expected. Elapsed times of several weeks are common from the time the colour separations are sent to the print shop until the time a multicolour paper chart is received

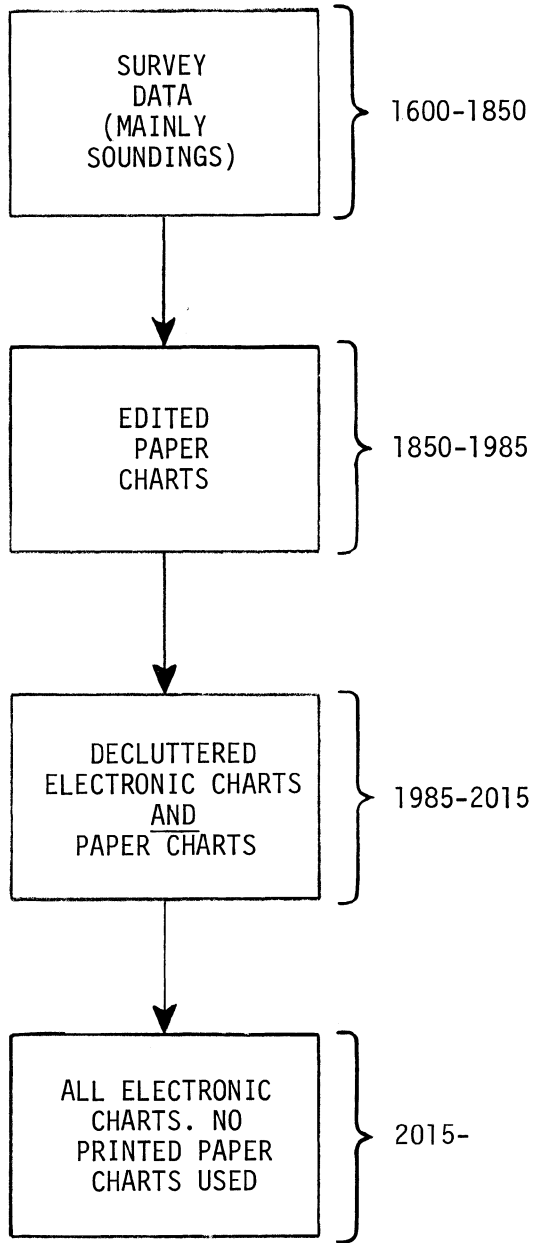

Figure 2.3 Evolution of Marine Chart Use

back. This is due to the inertia of the lithographic printing process. Modern presses can print thousands of multicoloured impressions per hour; it is the scheduling, setting up, registering and checking that consumes time.

Other aspects of the present chart production system can be improved through use of the computer. For example, Figure 2.4 shows the "qualified data base" (QDB) approach to combining many different hydrographic field sheets together at one common "chart" scale by first digitizing the original field sheets. This should improve the time spent constructing the chart mosaic (see Figure 2.1), a fundamental building block in the present CHS chart production process. The time-consuming operation of manually contouring the field sheet and selecting the soundings to be used from the field sheet is still required.

A conceptual problem is seen to exist with the QDB approach. As it exists, the QDB approach is geared entirely towards production of the final paper chart product. This is evident because

- (1) The original field sheets have their soundings selected and contours drawn with the scale of the final chart in mind. For example, field sheets at a scale of 1:10,000 are often used to compile 1:30,000 scale charts. This usually means that a lot of the soundings on the field sheet are ignored when digitizing.
- (2) The digitized field sheet data is discarded after it has been merged to produce the digital mosaic file for the final chart.

If this same area needs be done again at a larger scale or using a new chart scheme, the original field sheets must be again selected, contoured and digitized with this new chart scale in mind. The qualified data base should be a digital file of hydrographic survey data, plus contours

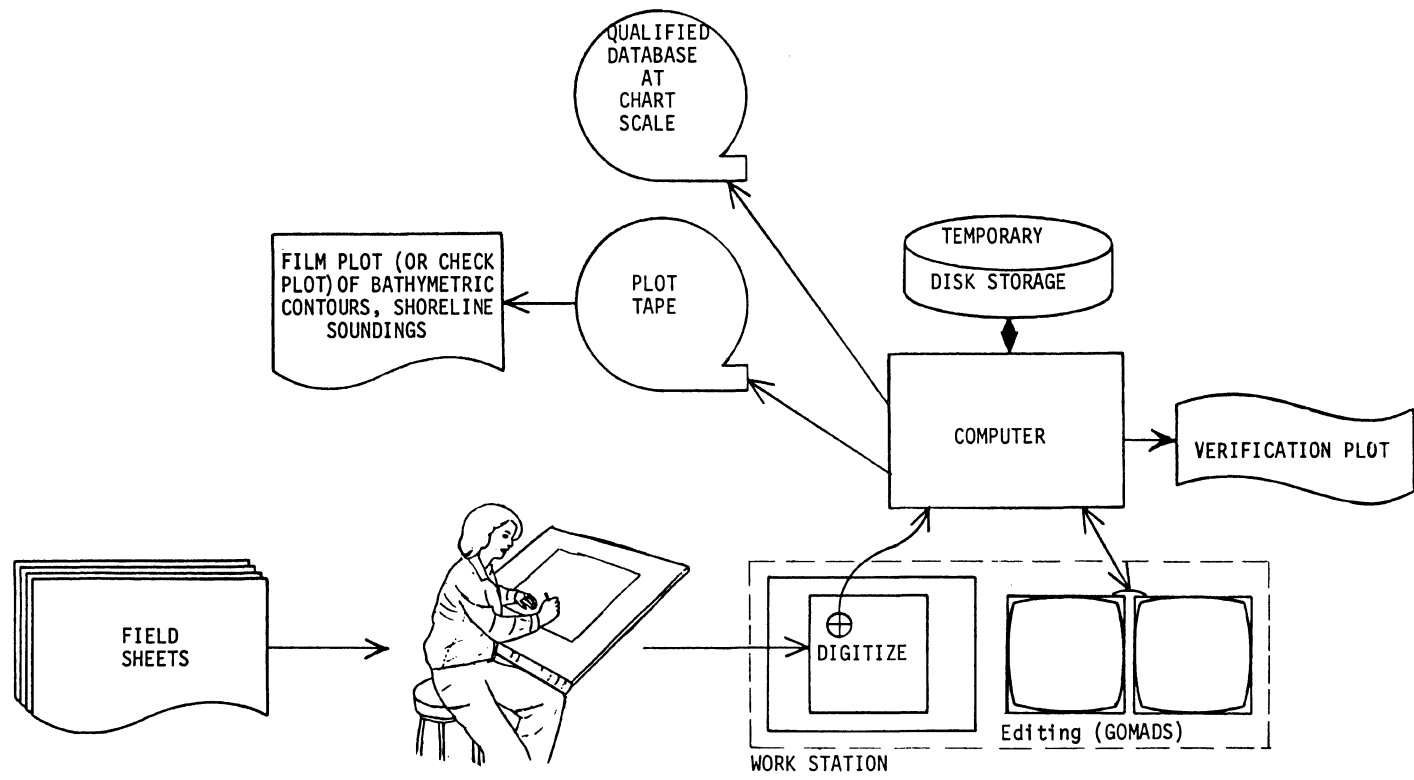

SOUNDING SELECTION AND CONTOURING

WORK STATION

1. Digitize field sheet; edit if necessary (GOMADS).
 - i) contours (shoal lines)
 - ii) selected soundings
 - iii) shoreline, foreshore (tidal zone)
 - iv) symbols (e.g. bottom quality, marshland, rocky shore, cliffs)
- 1.1 Produce a check plot for verification
2. Run MOSAIC program to combine digitized field sheets into 1 "MOSAIC" file called the qualified data base at chart scale. Edit if necessary (GOMADS).
 - 2.1 Produce a check plot for verification.
3. Run STARS to generate symbology.
4. Run NTXCAL (CALCOMP), STAR2 (GERBER), or NTXGC3 (KONGSBERG) to generate a film plot.

Figure 2.4 The Qualified Data Base Approach.

representing the data at the scale of the original field sheet. Different chart mosaic files can then be compiled by generalizing the digital field sheet data (either by program or interactively). The impact of interactive navigation systems which incorporate some form of electronic chart display is presented in section 3.2. There it is shown that the present CHS nautical chart production system cannot provide the electronic chart data needed by these interactive navigation systems.

Ready availability of large, colour video screens with high resolution (e.g., 60 cm by 60 cm with 4096 by 4096 pixels) will change the demands on the nautical chart data base. Paper versions of the chart become completely unnecessary for navigation; all of the detail on it can be displayed on the large, high-resolution video screen. The mariner will be able to select just the features he wants to see at any one time for any geographical area. Optical storage devices capable of storing all 400 of the Canadian Atlantic region nautical charts are presently being developed. Even the recently announced 4.7 inch diameter Compact Discs used for storing audio information have been conservatively estimated to be capable of storing 570 MBytes of data.

Data must be online and be capable of being maintained up to date on a regular basis (e.g., daily). One can then produce a disk for any geographical area at any time and be assured that the data is up to date.

By the time these large-screen displays are in wide use, reliable and relatively inexpensive satellite communications will also be widely used. Querying the chart data base for all corrective information issued in the last 6 months pertaining to a specific geographical area will be a common practice. To provide this capability, an online data base of Notices to Mariners must be available (see Chapter 4).

If satellite communications become inexpensive enough, one can conceive of transmitting the entire data base for a certain harbour area or shipping channel on an as-required basis. Ships then no longer need carry a chart inventory, even in the form of digitally recorded disks. The latest, up-to-date chart will be available almost instantaneously over the data link. This puts an even greater demand on maintaining the nautical chart data base in as current a fashion as possible. If one ship finds a lighted buoy extinguished in the St. Lawrence Seaway and reports it to the Coast Guard, the next ship to pass by the buoy should have received the updated chart information showing that buoy extinguished. Technology will certainly not be the main impediment to accomplishing this; in fact, technology now makes almost instant information relaying possible, where before it was impossible. As always, some organizational adaptation will be necessary to take advantage of this technological improvement.

3. INTERACTIVE NAVIGATION SYSTEMS

In Table 3.1 the diversity of hardware/software systems using electronic chart data bases is documented. At one end of the range there are video plotters, for use on fishing vessels and yachts, costing a few thousand dollars; at the other end there are interactive navigation systems, for use on very large ships, costing many millions of dollars.

All of these systems can display own ship's position, some track data, and some data from an electronic chart data base; some can overlay radar data, some cannot. In one system, navigation data is overlaid on the radar. A brief review of each of these follows.

3.1 A Review of Some Existing Systems

Evidence has been found of three manufacturers in the U.S.A. and of four in Japan who are producing one or more systems. These include

- Navigation Sciences Inc.'s VIEWNAV system;
- Sperry Marine Systems' CAS II collision avoidance system;
- Sperry Corporation's HICANS and COMDAC systems;
- Texas Instruments' TI 8000 Integrated Marine System;
- Furuno Electric Co.'s GD 200, GD 170 and RS 1000 (navguide) systems;
- Japan Radio Co., Ltd.'s (JRC) MWU-50A Color Plotter, its 150A Radar Adaptor, and its SNA 80 Total Navigator II systems;
- Tokyo Keiki Co. Ltd.'s Automatic Navigation Control and Display System (ANCDS) being built for the Japan Maritime Safety Agency.

These instruments all have different capabilities for plotting and storing electronic chart information. Table 3.1 summarizes the characteristics of

TABLE 3.1 Status of some systems with which electronic chart data can be used.

System	No. of Colours	Approximate Storage Capacity		Display Resolution	Range	Method of Chart Data Input	Approximate Cost (US\$)	Development Status 31 December 1983
		Line Data	Symbols					
(A) COLOUR VIDEO PLOTTERS. (Own ship's position, track data and, in some cases, other data such as temperature/depth profiles.)								
Texas Instruments TI 8000	7	560 points	56 points	192x192 (10")	2-110 nmiles	cassette; operator entered	10,000*	n/a
Furuno GD 200	7	3x500	combined with line data	512x385 (14")	0.5 -206 nmiles	cassette (optional); operator entered	11,000*	600 installed
Furuno GD 170	7	1000	combined with line data	240x320 (10")	1-384 nmiles	cassette; operator entered	4,000*	new (1000 expected by March 1984)
Japan Radio Co. NWU 50A	7	400	combined with line data	512x442 (13")	0.25-128 nmiles	cassette; operator entered	6,000*	over 1200 installed
(B) COLOUR VIDEO NAVIGATION PLOTTERS WITH RADAR ADAPTORS.								
Japan Radio Co. NWU 50A plus radar adaptor 150A	7	400 points	combined with line data	512x442 (13")	0.25-128 nmiles	cassette; operator entered	12,000**	} 43 installed 60 } 17 on order
Navigation Sciences VIEWNAV	7	64 KBytes	combined with line data	400x400	1-24 nmiles	floppy disk; manufacturer supplied and updated	40,000**	
(C) COLLISION AVOIDANCE SYSTEM WITH CHANNEL NAVIGATION OPTION (Chart data overlaid on radar displays.)								
Sperry CAS II	1	900 points	combined with line data	Radar PPI (16") plus alphanumeric display	1.5-48 nmiles	EPROM; manufacturer supplied	50,000	30 installed with the channel navigation option
(D) INTEGRATED BRIDGE SYSTEMS. (Own ship's position, selected chart data, radar or ARPA data, permanent record, linkage for automatic steering and, in some cases, for other shipboard functions.)								
Sperry HICANS/COMDAC	1	900 points	400 points	945x945	0.5-64 nmiles	cassette; manufacturer and operator supplied	6,500,000	4 installed
Japan Radio Co. Total Navigator SNA-80	7	3000 points	250 route 250 other	512x442 (14")	0.25-6000 nmiles	cassette; operator entered	12,000,000	15 installed 25 on order
Tokyo Keiki ANCDS	7	2000-4000 points	combined with line data	960x700 (20")	1.5-96 nmiles	cassette; manufacturer supplied to customer's specifications	400,000	1 installed 2 on order
Furuno Navguide RS-1000	7	4000 points	400	640x480 (20")	1.5-24 nmiles	cassette; operator entered	50,000***	1 installed
* For the plotters but not for the ancillary equipment. ** For the plotter and radar system only. *** Does not include any ancillary equipment.								

each one.

From a review of manufacturer's data and from discussions with several of them it is apparent that there are many variants ranging from a relatively simple video plotter (Table 3.1(A)) to a powerful integrated bridge system (Table 3.1(D)). Most manufacturers have their basic unit and a variety of optional ancillary units.

The four categories identified in Table 3.1 are somewhat arbitrary but they do emphasize some of the more fundamental differences in the configuration of the systems that are using nautical chart data in digital form.

Some of the low cost systems have been designed primarily for and are being used extensively by commercial fishermen; other low cost systems are being adapted primarily for the recreational market.

Some are designed primarily for harbour and narrow channel operations; others are designed for use by ocean-going shipping. Still others are designed for patrol and surveillance operations.

Briefly, however, the message with respect to nautical chart use is that the equipment is there and it is being used now by virtually every type of user of nautical charts.

No one set of equipment has the capacity to display chart data at a resolution that is at all comparable to the resolution of the nautical chart (see Chapter 2). Most of the displays provide for some 400 points (coordinate pairs) of line data at any one time; one display has provision for 3000 points and another has provision for 2000 points. No geographical names, topographic contours, deep water bathymetric contours, or roads are displayed on present systems. Textual information describing buoy and light characteristics is included for display on a separate CRT or in an

area reserved for textual information. Electronic display of navigation information must be decluttered due to both the limited resolution and size of the CRT and the present lack of larger memory to store information.

The priorities for chart data seem to be:

- shipping channels and designated areas;
- fixed and floating navigation aids;
- hazards and one depth contour (sometimes referred to as a shoal line);
- shoreline (sometimes by very few points linked by straight lines).

In addition, the need for features that will facilitate positioning by radar has been identified by several of the manufacturers.

The capability to superimpose radar data, either directly or via an ARPA on chart information, provides an excellent real time navigation tool as confirmation of LORAN-C or SATNAV positioning. Automatic recording and display of the ship's track relieves the officer on watch of the duty of constantly plotting the ship's position on the paper chart.

The above discussion shows that systems for the display of the electronic chart are already on the market. Indeed, they are now being used extensively as a primary navigational tool. The information content of each electronic chart data base depends on the system, on the person who digitized the data, and on the arrangements made for updating it. The following sections review some of the available commercial systems.

3.1.1 The VIEWNAV System

Navigation Sciences Inc. of Bethesda, MD, U.S.A. now has a prototype interactive navigation system called VIEWNAV. The main hardware components are built around an AI Electronics M-16 computer composed of

- a) an 8086/8087 central computer processor;
- b) two NEC 7220 graphics display controllers;
- c) an 7-colour video display terminal with 640 x 400 pixel resolution;
- d) one 10 MByte Winchester disk drive and one 1 MByte 8-inch floppy disk drive.

Positioning is provided by a MEICO C-MASTER IV LORAN-C receiver interfaced to the computer. All software runs under the CP/M-86 operating system with source code written in C. Digitized radar data is overlaid in red on the 7-colour display terminal.

During operation, the ship is shown moving on the display. As it approaches the edge of the display (e.g., within 25% of the edge), the computer "flips" over to the adjoining "page" of the chart data base. This repositioning of the chart image takes about 1 second. Chart scale is variable from 1 nmile on a side (approximately 1:5000) to up to 24 nmiles (approximately 1:120,000) on a side. Land areas are displayed in yellow, shoreline in black, deep water in light blue, and shoal areas in darker blue. The colour scheme was chosen to match the present U.S. paper nautical chart colour scheme as closely as possible.

The VIEWNAV system is intended primarily for shipping channel and harbour navigation. Its hardware is tightly coupled to a differential LORAN-C positioning system for precise navigation. Navigation Sciences Inc. provides a data base and an updating service to the customer's specifications to anyone using VIEWNAV (see section 2.4).

3.1.2 Sperry Marine CAS II System

The Sperry CAS_{TM}II Collision Avoidance System superimposes collision avoidance data on a standard 16" Plan Position Indicator (PPI) display. It also includes an alphanumeric data display for readout of information on tracked radar targets. Figure 3.1 contains a picture and simple block diagram of the CAS_{TM}II system. It is primarily designed to track radar targets (up to 20 simultaneously), and to provide collision avoidance data on them. Visual and audible alarms provide a warning automatically when a target is in a situation dangerous to own ship. Ship's heading and velocity is determined by interfaces to a gyrocompass and speed log. Two TMS 9900 and one INTEL 8085A microcomputer control the CAS_{TM}II operation.

The channel navigation option of the CAS_{TM}II system provides user specified shoreline, navigation markers, desired channels and navigation hazards, displayed on the PPI, i.e., a form of electronic chart. This so-called "harbour video map" is stored as latitude and longitude coordinates of points (coded as to feature type) in a bank of EPROM chips on a separate printed circuit board attached to the main interface and memory board in the CAS_{TM}II console. Ten lines are available to mark channels, restricted zones, etc., and a maximum of 900 points can be stored in the channel navigation option memory. This is enough for up to 8 or 9 harbours depending on the complexity of information in the harbour areas.

Information to be stored in the memory is first marked or flagged on a paper chart by a specific customer. Each customer will want different features coded depending on his vessel's size, draft, and handling characteristics. Positions (latitude and longitude) of navigation aids must also be provided by the customer. Sperry Corporation in Charlottesville, VA, then digitizes and enters the marked data for each

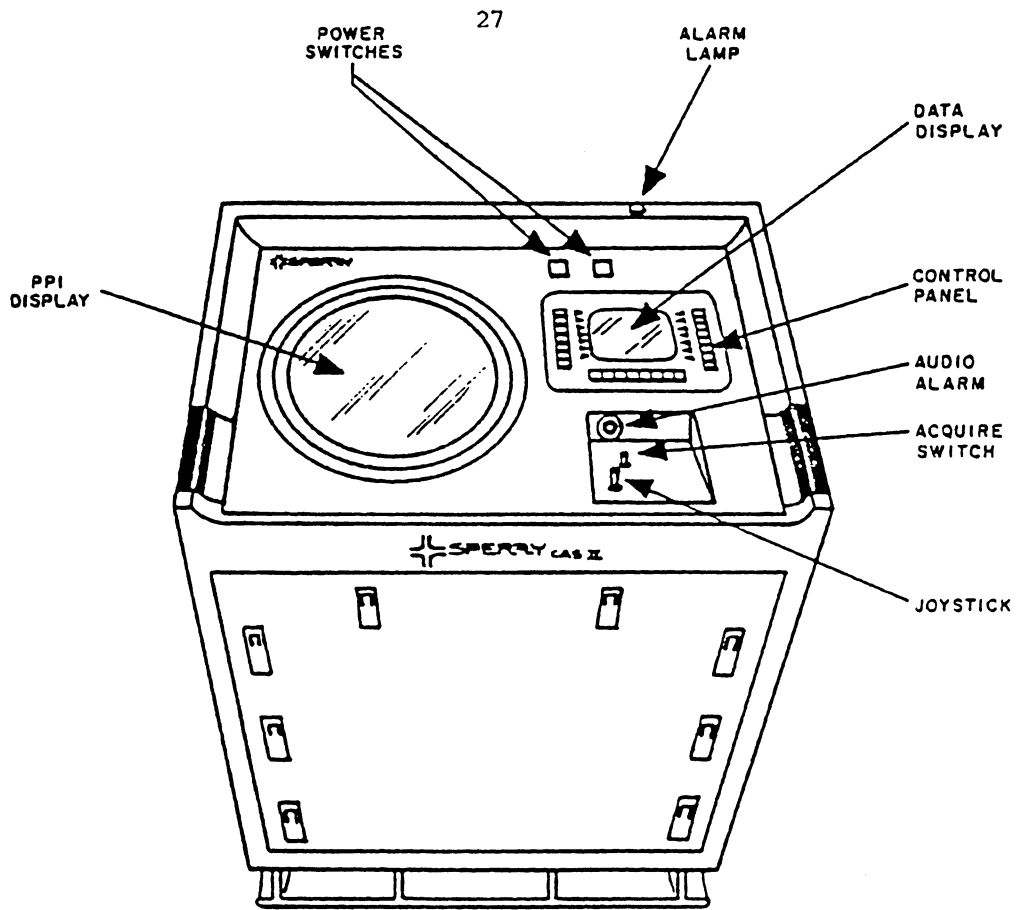

CAS II Console

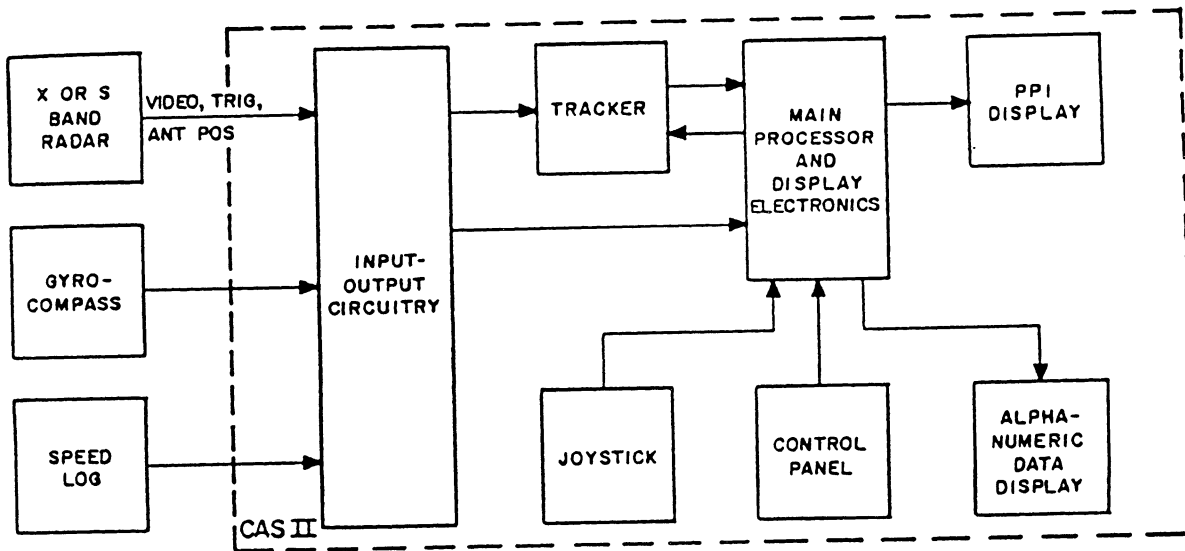

CAS II Block Diagram

Figure 3.1 Sperry CAS_{TM} II System

customer's memory. Any changes or updates to the memory contents must be requested by the customer before being performed by Sperry. Approximately 30 ships now have a CAS_{TM} II with the channel navigation option installed. Another 35 to 40 are expected to be sold in the next year.

3.1.3 HICANS and COMDAC

The High Speed Ship Collision Avoidance and Navigation System (HICANS) and the Command, Display and Control (COMDAC) system hardware were both built by Sperry Corporation in Reston, VA.

HICANS has been installed on the USS PEGASUS, a 130 foot hydrofoil capable of cruising in excess of 40 knots. HICANS can track up to 45 targets simultaneously and display their predicted path at present speed and heading as well as their position in 6 minutes. As explained by Lanny Puckett of Sperry Corporation in his paper presented at the 1982 National Marine Meeting of the (U.S.) Institute of Navigation, HICANS superimposes chart data on the radar display at a relatively high resolution (945 x 945 pixels) in one colour. Figure 3.2 shows the block diagram of HICANS and a typical digital chart display. The scale of the display is changeable from 1 to 64 miles. Information about any tracked target or navigational aid can be displayed on a separate data display by moving to the desired target with the track ball to "hook" it.

A typical digital chart contains buoys, visual sighting points, channel lines, and straight line approximations of shoal lines and prominent radar features. The present primary limitation is the generation and updating of these digital charts. Presently, a paper nautical chart is marked with the data to be obtained from it. The Defense Mapping Agency then digitizes it using their existing hardware and software. This data is

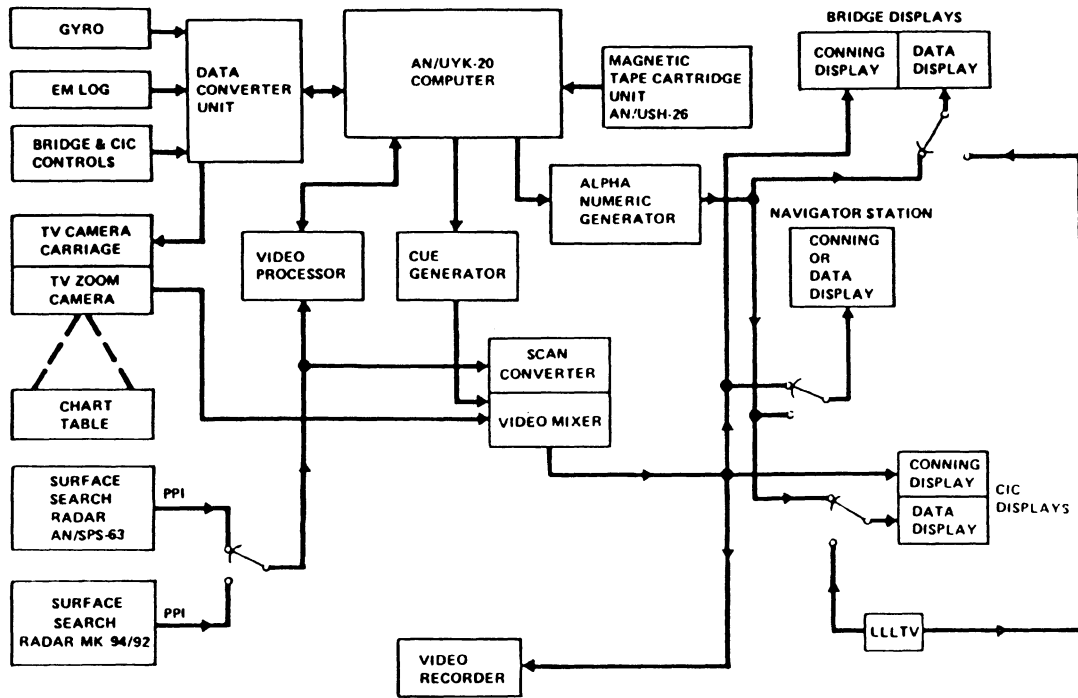

Block Diagram

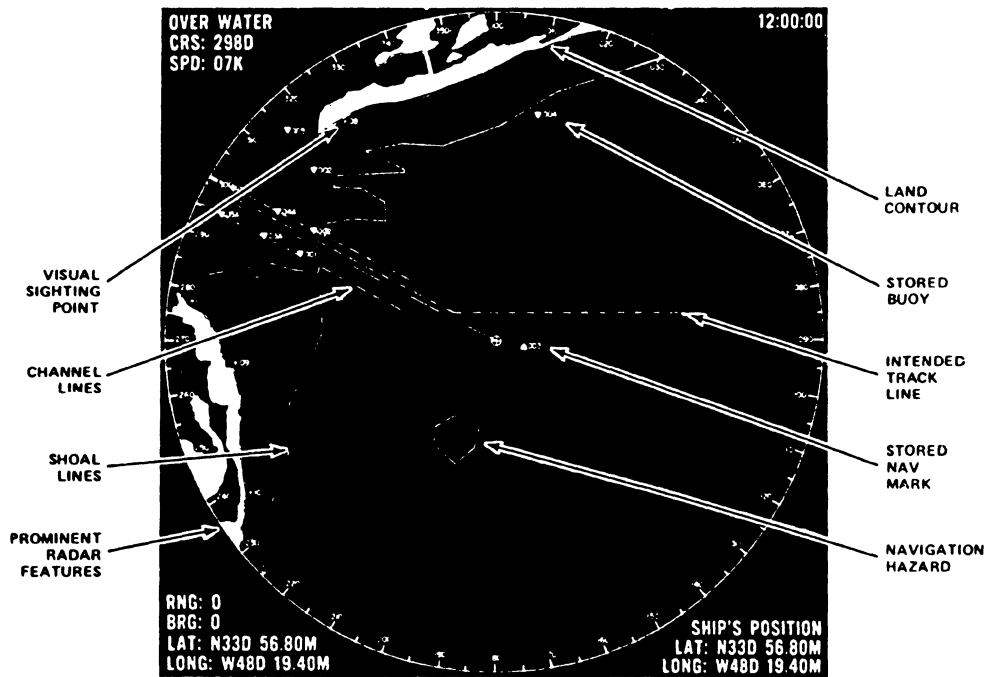

Digital Chart Display

Figure 3.2 The HICANS System

then provided to Sperry for conversion to the HICANS format. Shoal line and shoreline data are strictly limited by the memory size of the computer (AN/UYK-20). Even though several paper nautical charts make up one digital chart (e.g., 7 paper charts make up the Key West digital chart), data points for shoal line and shoreline are limited to approximately 320 points for shoreline and 160 points for shoal line.

At present, five COMDAC systems have been built and delivered to the U.S. Coast Guard (USCG) for installation on their new 270 foot medium endurance cutters (WMEC). In addition to automatic tracking of up to 64 radar targets, COMDAC integrates the navigation, communications, fire control, and video recording system of the ship (see Figure 3.3). Display of the digitized chart superimposed on the radar display (one colour, high resolution) is almost identical to the HICANS system. Figure 3.4 shows a typical "turnpoint and precision anchoring" graphics display containing shoal line, shoreline, and navigational aids.

Responsibility for both digitizing and updating the electronic chart data base for the COMDAC system lies with the U.S. Coast Guard ships' crews; on USCG ships jobs such as this are usually done by the quartermaster. A full-size digitizer is provided on board for this purpose. Digitizing is done on an "off line" basis. Table 3.2 lists the present types and maximum amounts of data captured for use with each electronic chart. One can see that the amount of data per chart is limited. A chart editing feature is provided so that the data base can be updated from Notices to Mariners.

Both the HICANS and COMDAC systems are expensive, integrated systems built primarily for military ship navigation and control. Nevertheless, their requirement for nautical chart data in an electronic form is still

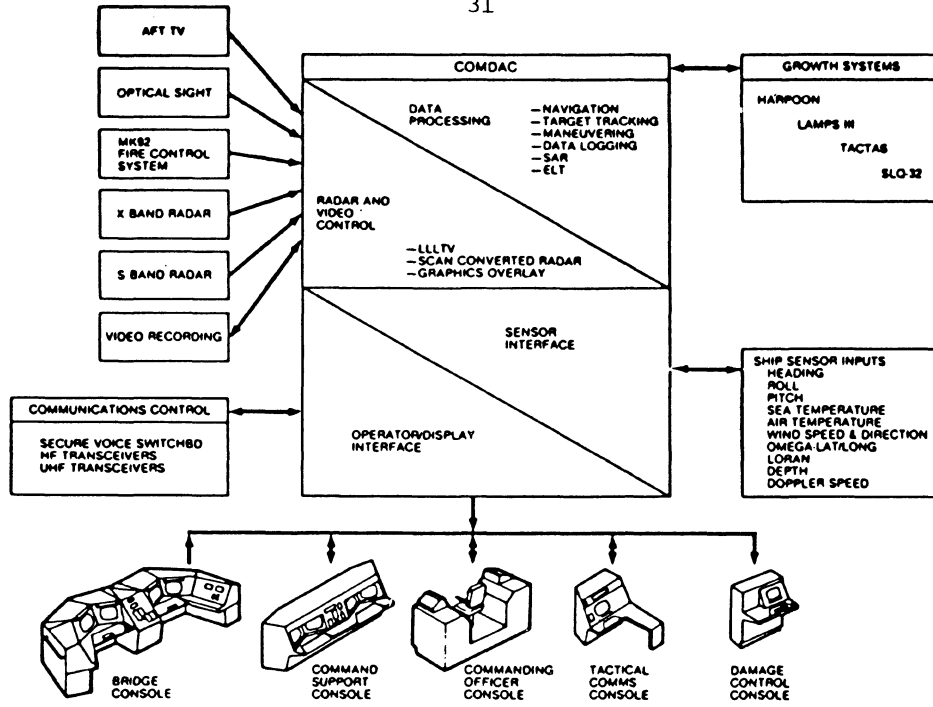

Figure 3.3 COMDAC Block Diagram

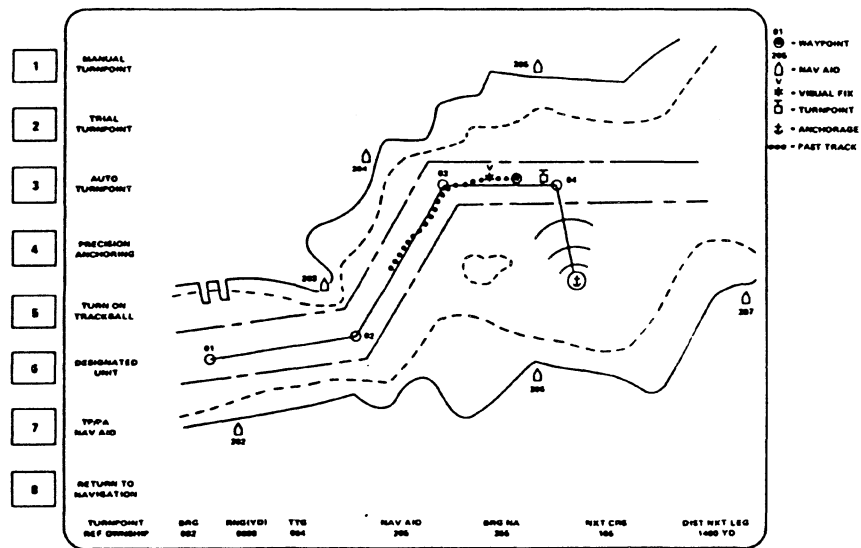

Figure 3.4 COMDAC Turnpoint and Precision Anchoring Graphics Display

TABLE 3.2 Chart Digitizer Buffers for the COMDAC System

NUMBER OF ELEMENTS PER NAVIGATIONAL FEATURE			
<u>Feature</u>	<u>Max Number Points</u>	<u>Max Number Lines</u>	<u>Max Number Line Segments/Line</u>
Radar Aids)	-	-
Visual Aids)	-	-
Floating Aid Buoys) 400 *	-	-
Navigation Hazard)	-	-
Channel Lines	-	12	8
Track Lines	-	12	10
Shoal Lines	-	20	8 **
Coast Lines	-	40	8
Danger Bearing Lines	-	4	1

* The total of radar aids, visual aids, floating aids, and navigation hazards allowed equals 400, with the operator supplying the appropriate mix.

** Shoal lines are to be made from a type 3, code 100 dashed line, as illustrated in the cue generator documentation.

the same as that for a commercial system. For the COMDAC system, this means increasing the duties of the ship's quartermaster; he will now have to update the data base for the electronic chart as well as maintain the paper chart.

3.1.4 TI 8000 Integrated Marine System

Texas Instruments' TI 8000 is intended as a fuel management, navigational aid and data logging instrument. The hardware consists of a 192 x 192 pixel, 10" colour CRT display with the capability of manually entering waypoints, shoreline or shoal line data, navigation aids or point hazards into the system. Up to 10 drawings of 56 lines each plus 56 user-entered features can be stored on each cassette, along with own ship's track and other log information. Lines are drawn in white on a blue background during the day, and at night are shown as yellow on a black background. Interfaces for SATNAV, LORAN-C, Omega, LORSAT as well as many other ship's sensors (e.g., digital scales, fresh water level, vessel alarms, oil pressure and temperature, rudder angle, bilge levels, etc.) are available. Responsibility for entering and storing any electronic chart information lies solely with the ship's operator.

3.1.5 Furuno GD-200, GD-170 and RS-1000 (Navguide)

The Furuno Electric Co., Ltd. has a series of three colour video plotters.

(1) Model GD-200 is a colour video plotter designed to connect with LORAN or a satellite navigator and display own ship's position, current course and past courseline, 10 waypoints, the destination point, event marks and courseline. They are stored in three memory blocks of 500 points

each. Chart data is input by the operator on an optional cassette unit. The basic unit does not provide a radar interface, but a unit that does interface with radar is available as an option and another option provides for display of water temperature/depth profile. Proximity to a specified waypoint is indicated by a buzzer. The basic features of this model have recently been incorporated in a smaller, more economical unit designated GD-170.

(2) Model GD-170 is described as a "compact inexpensive" plotting instrument. It, too, is designed to display own ship's position course data and selected chart features. It's memory capacity is 1000 points plus 10 waypoints; optional memory provides for three pages of free use and 6 pages of ROM map data with 1000 points per page. The display is in 7 colours on a 10" screen. It also has an approach alarm capability and an optional interface for displaying water temperature and depth data. It has no radar interface facility.

(3) Navguide (RS-1000) is a much larger unit with several features designed to meet the needs of merchant shipping for narrow channel and harbour navigation. It has a 20" screen and a track ball for easy alignment, such as positioning by aligning radar and chart data. Eight memory blocks can be transferred from cassette to computer memory, but only one block can be displayed at one time; each block can have 4000 data points plus 400 markers. The track can be set in advance, and there is an interface to link with Hitachi's Transoline system for automatic steering along the planned route. Positions from several navigation sources can be displayed with separate symbols allowing the navigator to decide on which to accept. It has alarm features and data logging options, including the capacity to re-display its own previous tracks.

3.1.6 JRC Colour Plotter

The Japan Radio Co., Ltd. (JRC) has a low cost line designed primarily for the commercial fishing vessels and a high cost line designed for large merchant shipping vessels.

(1) The NWU-50A colour plotter is the key component of the low cost line. It is a video track plotter with the added capability of displaying latitude and longitude lines, waypoints, and event points (which can be used to represent shoals or other hazards to navigation). It can be interfaced with LORAN-C, a satellite navigator, Omega, or DECCA (see Figure 3.5). The 13" colour CRT has a resolution of 512 x 442 pixels. Chart scales from 1:2000 to 1:1,000,000 can be chosen and up to 400 points can be manually entered by cursor and joined by straight lines to represent shoals, coastline or shipping channels.

Recently a radar adaptor, 150A, has been developed so that a radar display can be superimposed on the colour plotter along with chart data, track and event marks as described above.

(2) The SNA-80 Total Navigator II is designed to graphically display navigation information, such as own ship's position and course, chart data, and ARPA information, on a multi-colour plotter and to automatically control an auto-pilot using a microcomputer; with this system a ship can travel safely on a planned course with minimum fuel consumption. Either of the two radars can be linked through the ARPA unit to the display console. Options include a chart digitizer, a data recorder to record and reproduce chart data inputs, a remote display, and a remote keyboard.

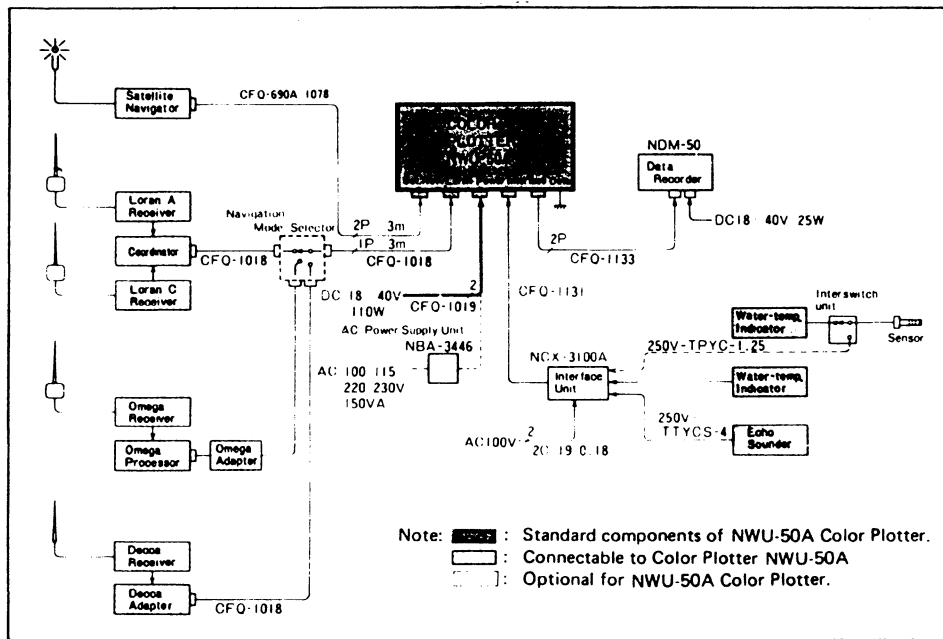

Figure 3.5 The JRC NWU-50A Color Plotter

3.1.7 Tokyo Keiki (ANCDS)

Tokyo Keiki Co. Ltd. are producing Automatic Navigation Control and Display Systems (ANCDS) for installation on the new patrol vessels (3800 gross tons) of the Japanese Maritime Safety Agency. The radar returns are digitized and displayed in 3 colours of blue (corresponding to high, mid and low returns) with the electronic chart information on a 20" colour CRT. Shoal lines are shown in red with the shoreline in white on a black background. A separate 12" alphanumeric display is used for textual information. Figure 3.6 is a plan/profile view of the ANCDS console.

Nautical chart information is digitized under the supervision of the Japanese Hydrographic Institute and stored on cassette tapes. Coastline information is digitized at less than 0.1' increments of latitude and longitude. A 20 m depth contour (shoal line) is digitized, along with the positions and characteristics of lights, latitude/longitude graticule intersections, and the limits defined by the Japanese Maritime Safety law. All of this information is to be obtained from 61 paper nautical charts at a scale of 1:200,000.

3.2 Navigation in Icy Waters

In The Electronic Chart, a report based on a workshop held at the University of New Brunswick in June 1982, two development scenarios were outlined. One was for harbours and other high traffic areas; the other was for areas, such as the arctic and the St. Lawrence seaway in winter, that are hazardous because of the presence of ice and the absence of floating aids.

As discussed in section 3.1, the electronics industry is moving rapidly on systems for high traffic areas but, because of the small market,

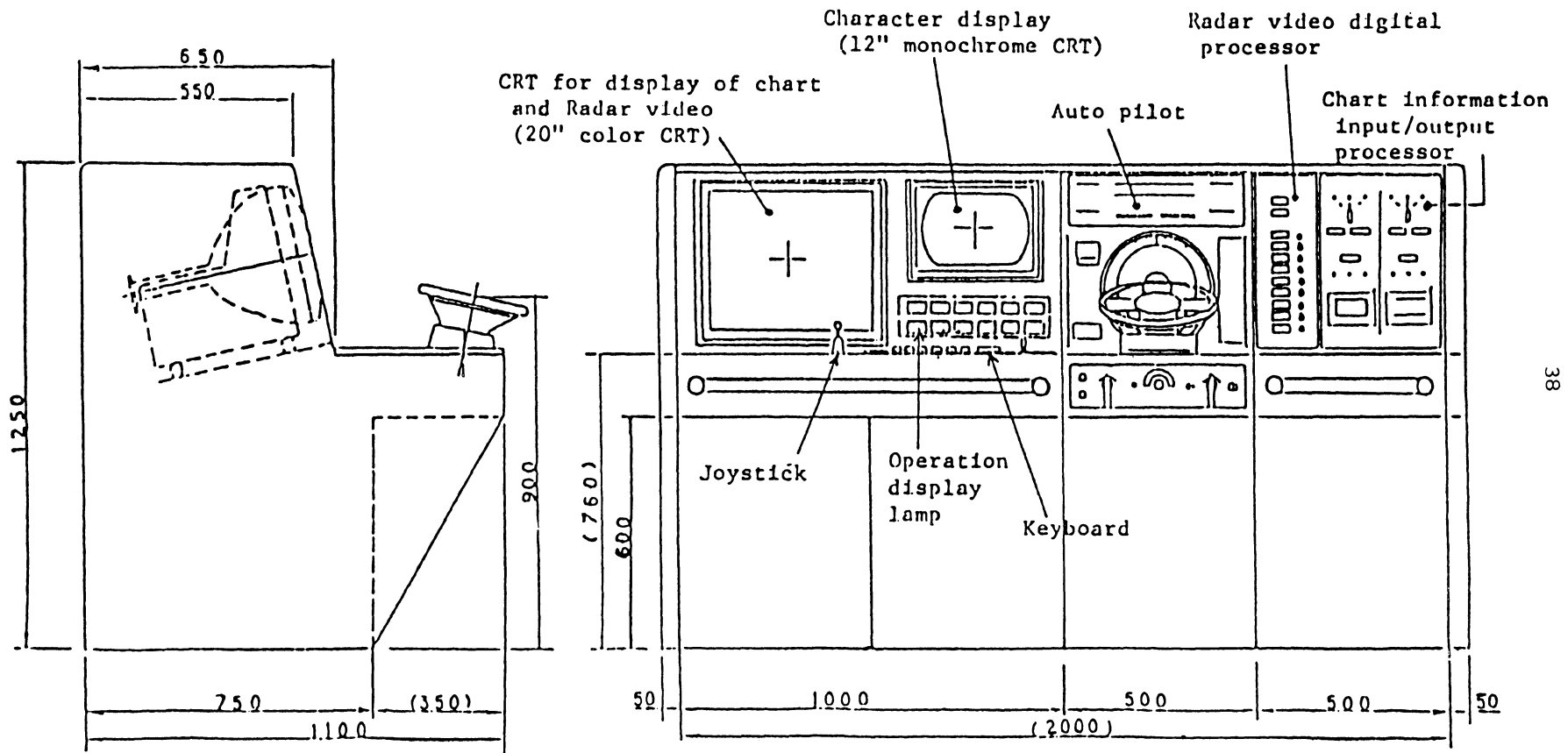

Figure 3.6 The ANCDs Console

there is little being done specifically for navigation where ice is prevalent. As stated in the above-mentioned report:

a bridge display of the actual coastline, any shoals or pingoes, and selected soundings would be extremely valuable. In addition, the capability to overlay real time transmitted ice charts...would be very useful.

When the shoreline is obscured by ice and the land is covered with snow it may, at times, be impossible to get either a reliable visual fix or a reliable radar fix. Even with good navigation instruments, such as gyrocompass, ship's log, GPS, or LORAN-C, any prudent navigator will want some reassurance about his position vis-a-vis nearby hazards. In other words, even with a CRT display showing the channel with the ship symbol moving correctly along in the channel, some redundant but independently observed data will be necessary.

In the arctic, position fixing is a particular challenge because

- (1) there is no LORAN-C;
- (2) the ship's log is often inoperable due to floating ice;
- (3) the gyro's performance may be degraded due to ice-avoidance manoeuvres;
- (4) visibility may be limited due to fog, blowing snow, or darkness;
- (5) even when visibility is good, there may not be any well-defined visible features.

Under these conditions, radar features, even those many miles from the shoreline, may make radar an invaluable navigation aid.

In view of the important role that radar is already playing in modern marine navigation with paper charts, it is reasonable to expect that radar will continue to provide the independent position check in navigation with interactive navigation systems and continue to be the prime navaid in inshore navigation. To do this effectively, the electronic chart needs to

have radar features, such as a "radar coastline", so that when the ship--and its displayed position on the electronic chart--are correctly positioned, the radar echoes will be superimposed on the "radar features" of the chart. This is an aspect of nautical charting that has not as yet been emphasized; it has, however, been recognized in at least one project. In "HICANS--Navigation for High Speed Ships", a paper published in the Proceedings of the (U.S.) Institute of Navigation meeting held at Cambridge, MA, in October 1982, Lanny Puckett listed the electronic chart data requirements as

channels, straight line approximations of shoal lines and radar features (recognizable land features, piers, bridges, etc.)

although, as his reference to piers, bridges, etc., indicates, Puckett was not preparing a system specifically for use in remote regions.

The concept of charting radar features and, in particular, of presenting a "radar coastline" will have two major impacts.

- (1) Nautical chart production agencies will have to re-align their chart compilation procedures and priorities.
- (2) With radar features displayed on an interactive navigation system, the technology for mariners to develop procedures analogous to IFR (Instrument Flight Rules) in aviation will be available.

Both of these will be discussed briefly.

3.2.1 Compiling a "Radar Features" Data Base.

As discussed in Chapter 3 above and in section 4.4, one of the most attractive features of the electronic chart is that the presentation is "decluttered". Thus in compiling a "radar features" data base it would be a regressive step to clutter it with topographic contours. It would be

ineffective as well because, to the topographer's chagrin, radar does not limit its echoes to contours; its echoes are a complex function of distance, angle of incidence, and many other factors. Thus, as shown in an illustration in the paper by Puckett, some form of hash marks is appropriate for representing land surfaces that will reflect radar pulses. The problem is further complicated by the fact that the strength of the echo depends not only on the feature itself but also on antenna height, radar frequency, distance offshore, gain setting, etc. It is not surprising, then, that in compiling nautical charts, no special effort has been made to identify radar features as such. For electronic charts, however, it is not unreasonable to expect to have two, three, or more versions of radar features (analogous to 2, 3, or 4 shoal lines) that might be selected automatically in accordance with the position of the ship.

With respect to compiling a "radar features" data base, the difficulties, as noted above, must not be underestimated. However it is probable that a first approximation would be compiled from analysis of topographic contours, and that a comparison would be made on shipboard and modified interactively in the same way that "field completion" is the final step in the compilation of good quality medium- and large-scale topographic maps. In some situations where there is a flat coastal plain and no significant features within radar range, it may be feasible to establish permanent passive radar reflectors. Although this option would be primarily for the arctic, it could well prove to be a cost-effective alternative for navigation aids in waterways in which the floating aids must be removed in the fall and re-installed each spring.

3.2.2 ISR: Instrument Sailing Rules.

Although the authors of this report have neither the expertise nor the mandate to discuss the rules and regulations pertaining to sailing in conditions of poor visibility, we cannot resist drawing an analogy between the IFR (Instrument Flight Rules) that apply to all scheduled airlines and to most other commercial flights. The harsh fact that the aviation industry has recognized for many years is that, with the possible exception of clear weather in daylight, it is much safer to rely on instruments than it is on human vision for air navigation. In the air version of the interactive navigation system, now in use on Boeing 767s, only the information that the pilot requires for navigation at any time is displayed on one CRT. The pilot can "clutter" his screen selectively by calling up any combination of weather radar, nearby airports, programmed waypoints, predicted flight path or VOR/DMEs in the area. The default display contains only the next waypoint and the planned flight path. This uncluttered display is the most comprehensible for normal en route aircraft navigation.

If radar features can be incorporated in the electronic chart data base of an interactive navigation system, it would appear that the technology will be available to enable marine navigation to have Instrument Sailing Rules, analogous to the Instrument Flight Rules in aviation.

The impact of radar features as an essential part of the electronic chart could lead to a shift in priorities for field work as well as for chart compilation in the CHS.

3.3 Impact on the Canadian Hydrographic Service

A fundamental change in the use of the paper nautical chart on the bridges of ships is now taking place. With these new interactive navigation systems, a ship's officer can easily see his own ship's position in relation to any charted hazards and navigational aids (along with any radar returns) directly on one CRT display. The necessity of constantly plotting own ship's position on the paper chart is eliminated since the computer can accurately display track history. In this sense, the paper charts' importance as a primary navigational tool is greatly diminished.

It is the CHS's mandate to provide mariners with reliable information about hazards to navigation (see Chapter 1). Presently this is done only in the form of the paper nautical chart. Two approaches to the supply of electronic chart information have been taken by the manufacturers. They are:

- (1) The manufacturer digitizes, stores and maintains the data in his own data base and distributes it to the mariner (e.g., Sperry CAS_{TM} II, HICANS, VIEWNAV).
- (2) The manufacturer supplies only the hardware, and lets the mariner digitize and manually prepare his own version of the electronic chart data base (e.g., TI 8000, Furuno, JRC, COMDAC).

In either case, independent bodies with widely varying interests end up controlling the information used by ships to navigate Canadian waters. Whether the information is reliable is out of the hands of the CHS. If the CHS is to live up to its mandate, it must provide reliable information about hazards to navigation in electronic form to both hardware manufacturers and mariners. This goes hand-in-hand with the end objective of providing safe navigation for ships in Canadian waters.

Resolution of CRT displays varies from approximately 0.3 mm to approximately 0.5 mm, whereas paper chart resolution is usually approximately 0.1 mm. The lower CRT resolution can be compensated for by an almost unlimited choice of scale. From Figure 3.7 it can be seen that for a 1000 pixel display at 1 nmile scale (the largest radar scale), 1 pixel depicts 1.8 m; however as the limit of useful accuracy is usually accepted as being approximately 10 m, there is no merit in having data for every pixel at this scale. Examples for smaller scales are shown on the figure.

The fundamental challenge in presenting chart data on a CRT is to "match" the data to the display specifications. In the ideal case a line (curved) extending from one side of the CRT to the other will be represented by approximately one data point for each pixel. Note that the number of pixels on a CRT diameter may be as low as 400 and as high as 1600.

Two examples of extreme cases may clarify the need for a good "match":

- (1) Not enough data points. If a curved line extending from one side of the CRT to the other is being represented by five points, instead of appearing as a curved line it will appear as five straight line segments.
- (2) Too many data points. If for the same line there are, say, 15,000 data points where only, say, 400 can be used, some software and some processor time must be provided to select the points to be used. This adds to the cost of the system and the additional processing load may impair the effectiveness of the display.

There are essentially two fundamental questions to be answered in order to develop a suitable national electronic chart data base. The first

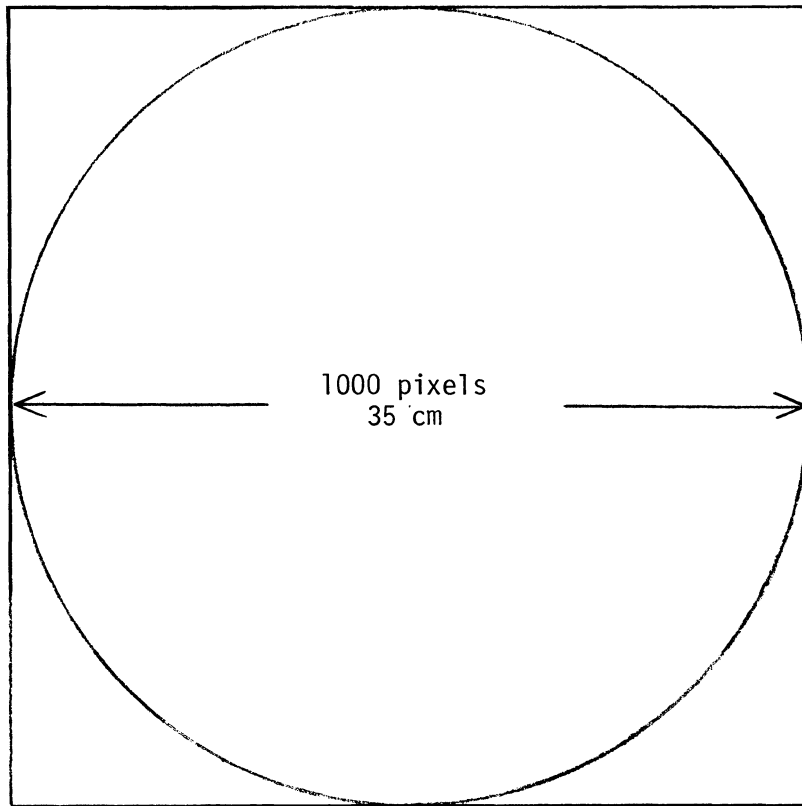

<u>Display Scale Diameter</u>	<u>Size of one pixel (m)</u>	<u>Scale assuming 35 cm width</u>
1 nmile	1.8	1: 5291
4 nmile	7.4	1: 21166
16 nmile	29.6	1: 84663
64 nmile	118.5	1:338651

Figure 3.7 Electronic Chart Display Resolution

question is: Which features should be included and which should not? As indicated in section 2.5, there is quite a clear consensus among the industry pioneers that the electronic chart data base should include only aids to navigation, shipping channel and anchorage designations, navigation hazards, the relevant shoal line, a simplified coastline and a few obvious topographic features. One additional class of feature for a Canadian data base is discussed in section 3.2.

The second and the more difficult question is: For a national data base, what is the optimum density at which line features, such as shorelines and shoal lines, should be digitized? In other words, how many points per centimetre need be digitized and stored so that the line can be adequately displayed? Recourse to the precedent of industry is of negligible value; this is because each industry has only one intended use for its data base whereas a national data base should satisfy all users that can reasonably be anticipated. Essentially it is a question of not enough points or too many points.

On the one hand, if there are not enough points, i.e., if the density is too low, there may be inadequate resolution for some applications. In compensation, there may be savings in digitizing costs, in storage costs, and in costs for generalization. (Generalization is the term used when the data density is to be systematically reduced.) Also the user can get by with a relatively simple, inexpensive processor and CRT in his interactive navigation system. On the other hand, if the density of line data is quite high, the costs for digitizing, for storage, and for processing are higher and generalization becomes necessary for most uses. Because there are now, and it is virtually certain that there will continue to be, users who want low density line data, there would have to be off-line facilities for

generalizing data. If the generalizing were done on the ship, special software and considerable computing power on board would be necessary. To arrive at the optimum density at which line features should be digitized an evaluation project is proposed.

In Figure 3.8, the components of a system to generate data bases for the electronic chart are depicted. The end product of this system is a computer tape (or similar digital storage medium) containing chart information for a specific geographic area. This differs fundamentally from the present chart production system which is entirely geared toward producing printing plates for separate colours to be used by the printing press (see Chapter 2). Another difference is the necessity to update the information directly from the Notices to Mariners in as timely a fashion as possible. From the review of the present interactive navigation systems in section 3.1, only four types of information are presently seen as necessary for inclusion in the electronic chart data base. This is a subset of the data presently depicted on the paper nautical chart.

Organization of the data in this data base should be in a two-dimensional structure. Both the NOS/AIS data base and the NSI data base store information referenced to latitude/longitude graticule intersections (e.g., all data in one, 5 minute block stored together). This greatly facilitates searching in a two-dimensional world, and also ensures that only one definition for specific chart features exists.

In summary, the interactive navigation systems reviewed here show that there is a definite need for nautical chart information in electronic form. The capability to change the scale of the display as desired means that the true positions of both navigation aids (e.g., buoys) and navigation hazards (e.g., shoals) must be provided as accurately as possible. Organization of

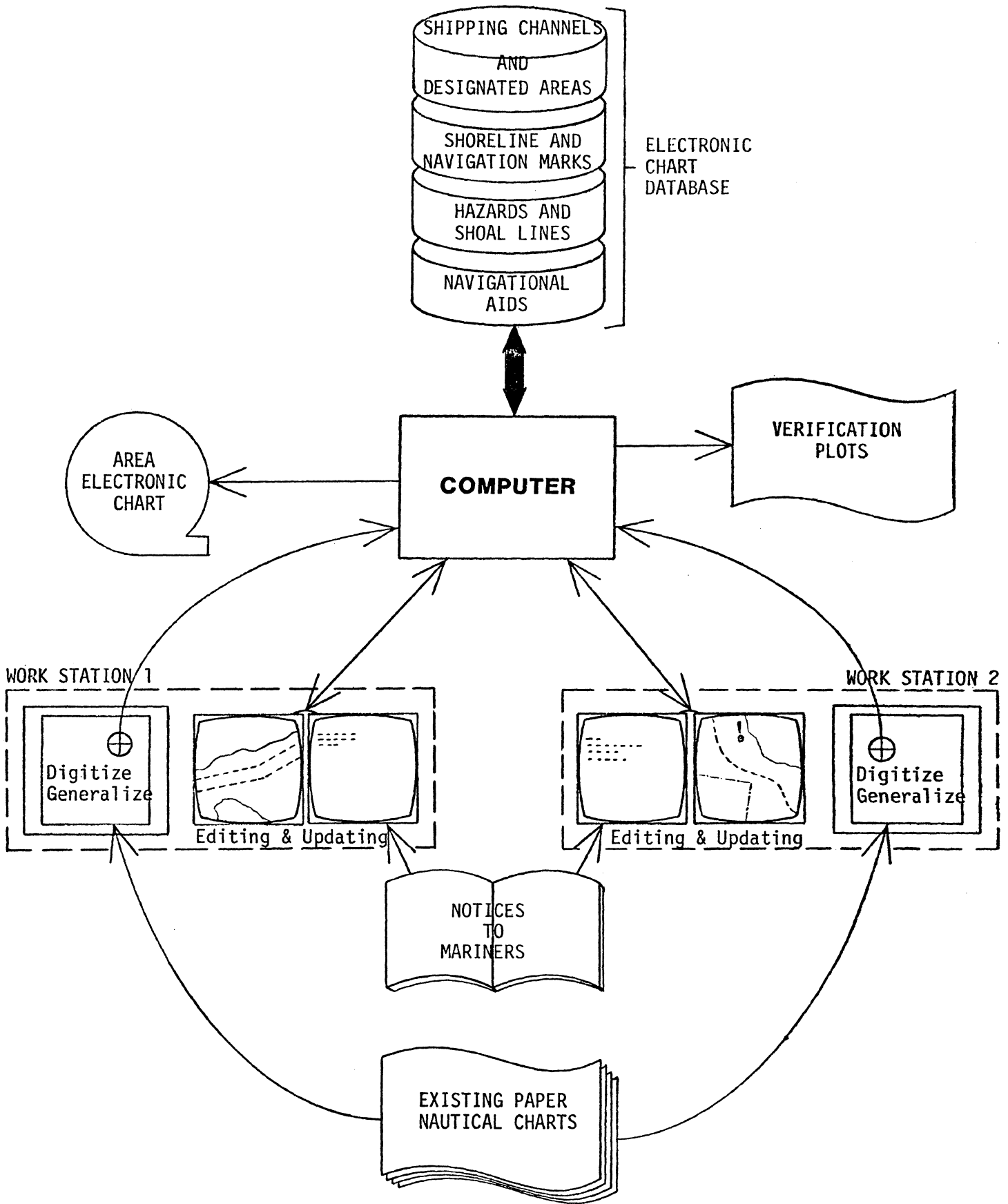

FIGURE 3.8 Production System for the First Generation of the electronic chart data base.

the data in a geographically referenced data base ensures only one definition of any information, enhances the capabilities to update the information, and greatly facilitates requesting information for a specific geographic window.

3.4 Statement from the Hydrographic Department in Japan

The staff of the Hydrographic Department have concerns similar to those identified above. Mr. K. Yashima prepared the following remarks:

Concurrent with the many developments in the private sector in Japan, the Hydrographic Department has been carrying out various investigations and surveys on the actual condition of the present electronic chart as well as preparing criteria on chart information and selecting and checking such chart information to be digitized and stored on the cassette tape for the ANCDs system since 1982.

While a definite policy in this field for the future has not yet been formulated in our Department, digitization of chart information and development of software are now being made by the Hydrographic Department in order to prepare the electronic chart data base (master file) since it will become necessary for the Department to provide the users with such chart information.

Several problems have been identified:

(1) Update of chart information. Electronic chart systems are at present used for offshore areas only. However, when such a system is further developed and used for narrow channels, inner bays, etc., in the future, various problems may arise.

(2) Disunity in colouring and symbols. Colours and symbols used in these systems are now different in every manufacturer, and the present phase is not yet ready for providing standard specifications. In the future the Hydrographic Department may have to provide a certain guideline in this respect.

(3) Superimposition with radar images. There are still some difficulties in superimposing on the CRT images of coastlines obtained by radar and those of chart information stored on the cassette tape. Accordingly, it is considered necessary, for example, to include in the chart information data file such landmarks conspicuous on the PPI.

(4) Future role of the Hydrographic Department. While the Hydrographic Department is responsible for providing chart information digitized, how deep can the Department intervene in the movement of manufacturers in view of ensuring the safety of navigation?

(5) Free choice of chart scales. Should there be an attempt to restrict mariners use or misuse of charts at certain scales?

(6) Name. The Department has reservations about the use of the term "electronic chart".

4. KEEPING CHARTS UP TO DATE

4.1 The Responsibilities for Chart Updating and the Sources of Data for Doing so

To be fully useful, all charts, whether on paper or in electronic form, must be kept up to date. In this chapter the present methods for keeping charts up to date, including the production of Notices to Mariners, will be discussed along with progress on the automation of Notice to Mariners by the Defense Mapping Agency in the United States. This discussion is followed by the rationale for the transition to automated procedures for providing mariners with the information that they need to keep their chart base up to date.

Before discussing the details of the production of Notices to Mariners, it will be helpful to look briefly at all the sources of information available to mariners. These are listed in Table 4.1, along with the agency responsible for their production, and the revision/update/response time for each of the products. As indicated in the table, the revision/update/response time ranges from as much as 30 years for charts down to 1 hour for the broadcast Notices to Shipping. Despite the many sources of updating information, it is very clear in maritime practice that the responsibility for keeping charts up to date rests with the mariner. There is an explicit obligation on national governments to provide the information promptly, and it is especially important that they reveal any information pertaining to hazards that they may be aware of; nevertheless, the onus for getting the up-to-date information onto the chart is placed squarely on the mariners' shoulders.

There are essentially three levels at which updating can be

Current Status			Electronic Chart Requirement
Product	Revision/ Update/ Response Time	Responsible Authority	
Charts	5 to 30 years	CHS	Selected items in digital format
Sailing Directions (12 vols) Small Craft Guides (5 vols)	2 to 5+ years	CHS	No change
List of Lights, Buoys and Fog Signals	1 year	CCG	No change
Notices to Mariners annual summary	1 year	CCG) All of these need to be available in) digital format via various communications) links on a 24 hour query basis.)))
Notices to Mariners	3 weeks +	CCG (+ CHS)	
Notices to Shipping Weekly summary	1 week	CCG	
Notices to Shipping mailout	1 day	CCG	
Notices to Shipping broadcast	1 hour	CCG	

TABLE 4.1 Information for Mariners in Canadian Waters.

considered. For vessels on the high seas, there is the Notice to Mariners, for example, as broadcast by the Defense Mapping Agency of the U.S.; the automation of this source is discussed in section 4.3. There are Notices to Mariners published weekly for all Canadian waters. And finally there are Notices to Shipping broadcast hourly and supplemented by frequent mailouts and by weekly summaries for the different districts managed by the Canadian Coast Guard.

The first level in the hierarchy of the information to mariners is, as discussed above, Notices to Shipping, commonly abbreviated to NOTSHIPS. As indicated in Figure 4.1, the data comes from many sources and is propagated by the available media; however, the main outlet is through the Coast Guard marine radio supplemented by the CBC fishermen's broadcasts. For notices of items that are of a permanent or at least a long-term significance, either as hazards or aids, an immediate mailout to the local mailing list may be made or the item may be included in the weekly NOTSHIPS summary. All NOTSHIPS are passed to the editors--Coast Guard and Hydrographic Service--for possible inclusion in Notices to Mariners.

Needless to say, there are many items in the Notices to Shipping broadcasts that are of a temporary or transitory nature; these include objects that may be floating in the harbour, temporary light failures, and other items which would not be considered for Notices to Mariners or for permanent notation on a chart. Nevertheless, from time to time there may be important items, such as the discovery of a shoal, that would appear first as a Notice to Shipping then as a Notice to Mariners and ultimately in the appropriate Sailing Direction volume and on the chart when it is revised. It follows then that there is a clear and logical hierarchy in the different methods of communicating information to mariners.

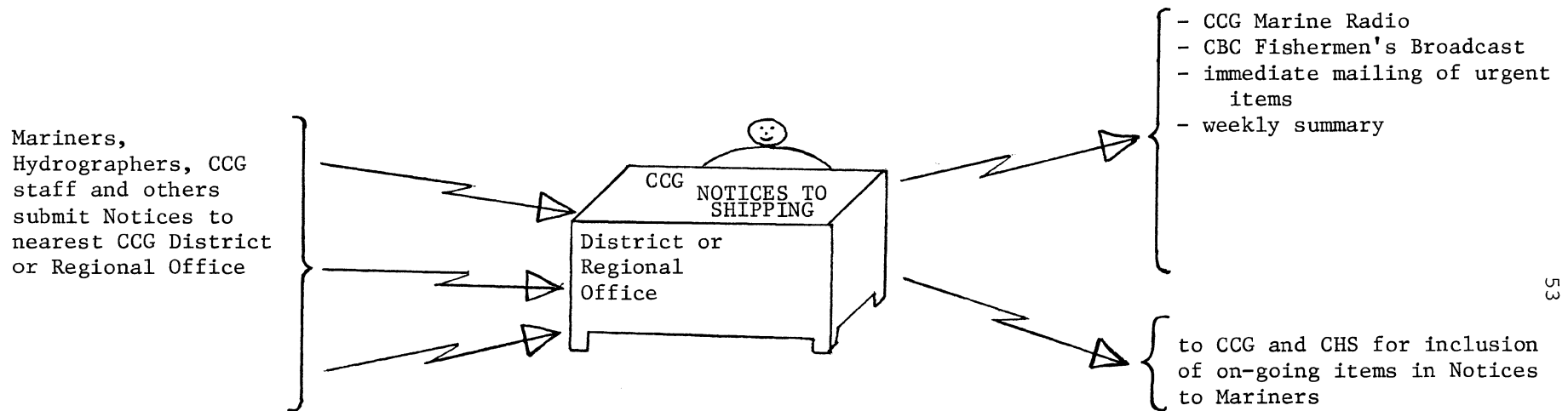

FIGURE 4.1 Notices to Shipping (NOTSHIPS) is a CCG service to alert mariners to anything of an urgent nature that may contribute to marine safety. In eastern Canada, NOTSHIPS are distributed from Saint John, N.B., Dartmouth, N.S. and St. John's, Nfld.

4.2 The Production of Notices to Mariners in Canada

Notices to Mariners is a weekly publication mailed to anyone with a maritime interest who requests that he be placed on the mailing list. More than 14,000 copies are sent to a worldwide mailing list; the purpose of Notices to Mariners is to enable everyone everywhere who has a Canadian nautical chart to be able to update it.

The main steps in the production of Notices to Mariners and related publications are shown on the flow chart (Figure 4.2). From discussions with officials involved on a day-to-day basis, it quickly became apparent that no flow chart could depict in detail all the input channels to the editors of the Notices. With Canada's sparse population and its coast on three oceans, many unofficial sources are needed to complement official sources of input on the status of the aids and the hazards in Canada's coastal waters.

The challenge of publishing the Notices is further compounded by the fact that the responsibility for nautical charting is with the Canadian Hydrographic Service and the responsibility for aids and waterways is with the Canadian Coast Guard. Despite the difficulties in getting and verifying facts on hazards and aids to navigation, the two groups do succeed in publishing Notices on schedule each week and in publishing two lists annually:

- (i) A list of preliminary (P) and temporary (T) Notices still in force,
and
- (ii) A list of Notices to Mariners still in force, indexed alphabetically
by location (e.g., Halifax harbour, Mahone Bay).

However, there is no list of Notices to Mariners applying to specific charts.

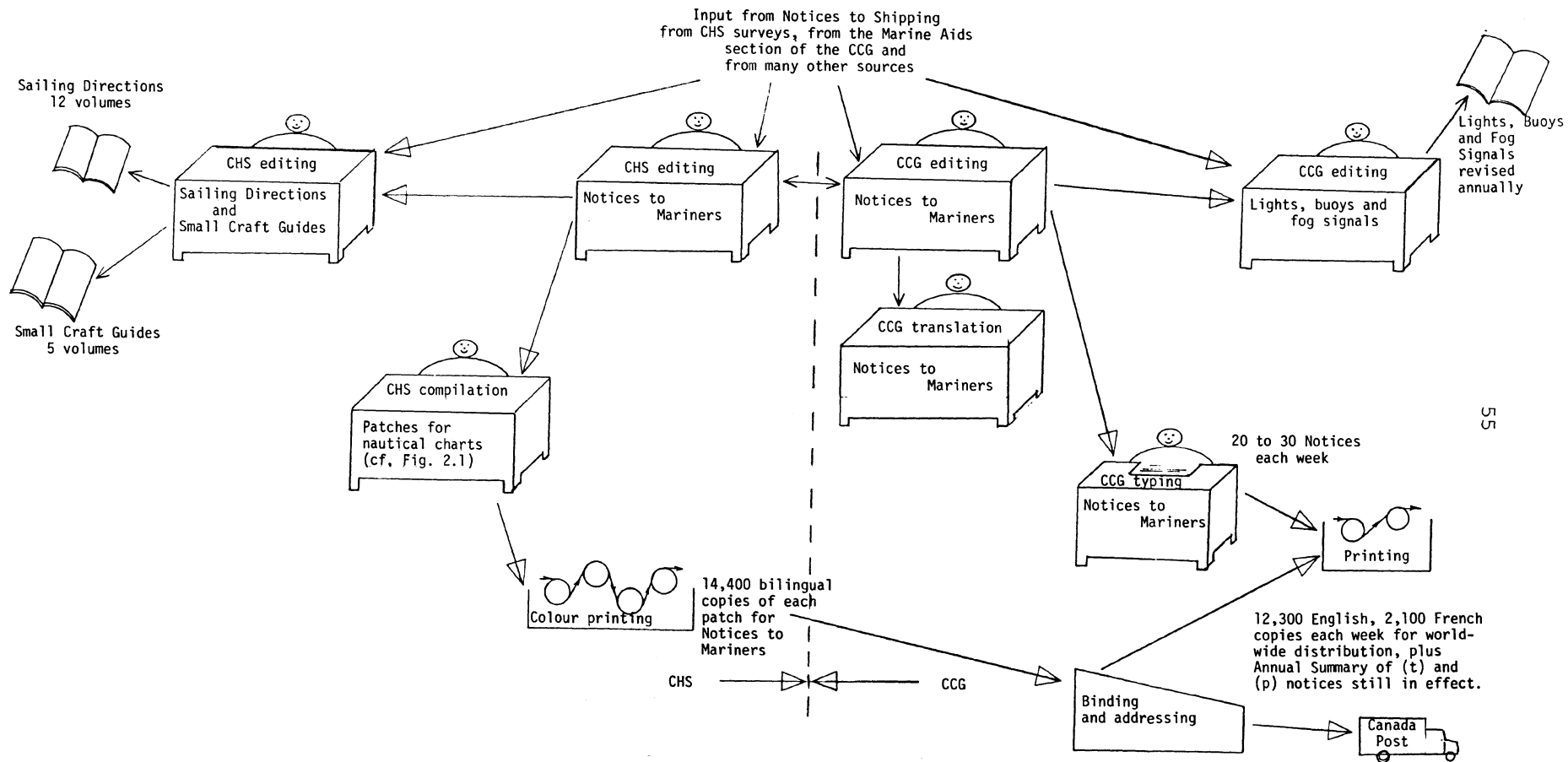

FIGURE 4.2 Flow Chart for Production and Distribution of Weekly Notices to Mariners and the Annual Summary of Notices in effect at the end of the year. From the same source files the CHS periodically updates its series of Sailing Directions and Small Craft Guides and the CCG updates its publication "Lights, Buoys and Fog Signals".

As depicted in Figure 4.2, 20 to 30 Notices per week are passed between the two editors until thoroughly checked and then sent for translation and typing and verified again before being sent for reproduction and mailing.

When the results of a survey with a large number of relevant soundings become available or when, from some other source, there are many changes or additions to one section of a chart, a "patch" is compiled. The process in patch compilation is similar to that for chart production; the only difference is that a patch covers a relatively small area--usually a rectangle with sides ranging from 10 to 30 cm in the chart. The release of a chart patch is listed as a "Notice", and a copy of the patch is included with the Notices so that the mariner may overlay the patch on his chart. As discussed subsequently, patches are overlaid on those charts held in the CHS stockroom.

Associated with the production of Notices to Mariners there is the task of updating the 12 volume publication Sailing Directions, the 5 volume Small Craft Guide, and the one volume Lights, Buoys and Fog Signals. Sailing Directions and Small Craft Guides are published by the CHS and revised periodically as required; Lights, Buoys and Fog Signals is published by the CCG and revised annually.

These three publications and approximately 1000 nautical charts are Canada's response to its obligation to inform the national and international maritime community about the hazards and aids known in Canadian waters. Notices to Mariners announce formal changes to these sources, and Notices to Shipping serve as an early warning system.

Although Notices to Mariners are published on a weekly schedule, it is implicit that the content of the Notices cannot contain all the changes

that have occurred right to the date of mailing. As is readily apparent in Figure 4.2, there are several time-consuming steps in the production of the Notices. Thus it is necessary to have a cut-off of input two weeks prior to the mail-out date. This editing and checking interval along with the delivery time means that, in effect, there is a delay of at least three weeks between the reception of a change by the editors of the Notices and the receipt of the Notices by mariners.

4.3 Status Report on Automation of Notices to Mariners by DMA

- by Morris F. Glenn*

The Defense Mapping Agency (DMA) was established in 1972 to provide mapping, charting, and geodesy support to the U.S. Armed Forces and all other national security operations. By statute, DMA also serves the needs of the U.S. merchant marine worldwide and of navigators generally on the world's oceans. The Hydrographic/Topographic Center (HTC) of the DMA has approximately 3,900 people who provide mapping, charting, and geodesy products and services to the U.S. Armed Forces and for the U.S. merchant marine, allied military forces, and navigators generally on the world's oceans. The Navigation Department is concerned with maritime safety and marine navigation. They compile Notice to Mariners and Sailing Directions and keep other products current through an interchange of information with all the major seafaring powers.

Information for the Notice to Mariners is contributed by:

*This section has been prepared by merging and abridging two papers by Morris F. Glenn, Navigation Department, Defense Mapping Agency, entitled "A new data resource for nautical cartography: the automated notice to mariners" and "Chart corrections via global communications systems", along with some introductory statements from some D.M.A. brochures.

- (i) The National Ocean Service (NOS), Charting and Geodetic Services which is charged with the surveys and charting of the coasts and harbours of the United States and its territories.
- (ii) The U.S. Coast Guard (Department of Transportation) which is responsible for the safety of life at sea and the establishment and operation of aids to navigation.
- (iii) The Corps of Engineers, U.S. Army (Department of Defense) which is charged with the improvement of rivers and harbours of the United States.

The weekly Notice to Mariners includes the following formats:

- Section I: Chart corrections; coast pilots/sailing directions corrections; catalogue corrections--new charts and publications; chartlets/depth tabulations/notes.
- Section II: Light list corrections; radio navigational aids corrections; other publication corrections.
- Section III: Broadcast warnings; marine information--miscellaneous.

The Automated Notice to Mariners System (ANMS) is a new automated system for the computerized typesetting of the Weekly Notice to Mariners and periodic Summary of Corrections publications. The Chart Corrections Sections of these two publications are the largest and most important sections and, as they offered the greatest savings through automation, they were designated as Phase I of the ANMS. The software for it was essentially complete by 1981, and it is now a fully operational subsystem of the ANMS. The mature data base consists of 26 megabytes (mb) of data and it is used to produce the Summary of Corrections.

The List of Lights corrections and Radio Navigational Aids corrections were scheduled for Phase II; the software is complete and work on the data

base was nearly complete in the fall of 1983. The text of DMA Broadcast Warnings were also added to the ANMS as part of Phase II automation. Phase III will include Sailing Directions corrections and Catalogue corrections. The phased approach to the development of the automation plan was selected to provide the earliest initial capability to use the hardware and begin realization of manpower and time savings.

Although the primary output of the ANMS will be page negatives for printing the Notice to Mariners, new Summary of Corrections, List of Lights and eventually Sailing Directions, the data base has multiple uses and benefits. It can be queried from anywhere in the world, via modern communications equipment, on a 24-hour basis by the entire maritime community. Not only will the printed publication be available sooner to the mariners in port but, at sea, the latest navigation information will also be accessible with commercially available communications equipment.

Users will be military ships and a wide variety of merchant vessels. As the size and speed of ships have increased, conversely the size of the crews and the time that can be devoted to the important task of correcting charts and publications aboard ship have decreased. Recognizing this turn of events, some charting agencies provide supplemental material with their Notice to Mariners to alleviate the chart correction task for the navigator. Such additional material is helpful, but it increases the production workload. When the ANMS is fully operational, the latest chart correction data will be available to mariners before they enter port or sail their ships into shallow or otherwise dangerous areas. As a separate developmental effort, Navigational Broadcast Warnings have also been made a part of the ANMS data base.

Since the Notice to Mariners is a weekly publication, when the due

date for publication is reached, the print cycle is begun on the computer. A Photon tape is produced by the Weekly Production Print Cycle, and this tape is run on a Photon Pacesetter Mark III to produce a high quality negative. This negative is used to print the Notice to Mariners. Also, at that point, there is a History File Update and a Summary File Update for the ANMS data base. The Summary File forms the data base for subsequent navigation publications and for public use. As a benefit to mariners in general, the ANMS is equipped with query programs. These programs output navigation information in a variety of formats that will provide the remote user with a rapid chart correction capability. In order to optimize use of long-distance communications, chart corrections may be ascertained from the last printed Notice available on board the ship, and the navigator may query the data base for later corrections. The data base may be queried for all the effective corrections pertaining to a chart or up to 10 charts on one query. User instructions (see Appendix II) enable maritime users to make the most effective use of expensive communications time.

New commercial global communications systems, such as INMARSAT, can provide instant links to the DMAHTC data base from anywhere in the world. At present, a query may be placed over the Telex keyboard of the shipboard satellite terminal or a telephone query may be made if the user has a small inexpensive data terminal with acoustic coupler attached. There are four commercial data lines installed at DMAHTC and one Telex line. The user dials in over one of these communications links and, as mentioned earlier, there are several public-use options to query the available DMAHTC data base. At sea, users could use the Telex system or one of the voice-grade channels of the INMARSAT system. The "land-line" communications link is the less expensive alternative. This could be used from any port in the

world and allow the ship's navigator to correct charts. Further, it would be of great use to cover unplanned changes to his schedule or to ascertain the very latest navigation information. It is too early at this point to predict the number of "at-sea" and remote "in-port" users of this system (summer of 1983 there were 342 remote users of ANMS placing 4000 queries). It is a new and revolutionary capability, and factors, such as reduction of insurance rates and burden of proof in marine accidents, could greatly affect it's usage.

Probably the most important contribution that the ANMS will make to nautical cartography is a capability to query for new chart corrections at any stage of chart production. During normal chart compilation procedures, the chart corrections will be requested at the beginning of the task. The capability to query the data base for any new corrections which were recorded during compilation will be an important new benefit for cartographers.

4.4 Rationale for the Transition to Automated Procedures for Canadian Notices to Mariners

In the preceding chapters, strong evidence was presented leading to the conclusion that the electronic chart is going to assume a major role in marine navigation in the very near future. Although, as shown in Table 4.1, much effort now goes into insuring that mariners can keep up to date on changes affecting safety, it is doubtful if there is anyone involved with this activity that is not at least occasionally frustrated by the delays and by the difficulties in making the system work.

In the long-term (20 to 30 year) scenario (see section 2.5) outlined above, it is not difficult to visualize a situation where the entire chart

system is in digital form and there are communication links such that any mariner can query the central data base and get an immediate or an almost immediate update of his files. As outlined in section 4.3 above, this is technically possible now. If this seems a little far-fetched, one has only to reflect on what has happened in the airline reservation business during the last decade; it is not difficult to remember when each airport was allocated a certain number of seats on a flight, and only after much delay was it possible to find out whether additional seats could be sold at that airport. Now, travel agencies and sales offices anywhere can check the central data base and find out in a matter of seconds, or at most in minutes, whether there is a seat available on any of the major airline flights. The improvement in electronic communications has corresponded with a deterioration in postal service such that electronic mail is becoming more and more feasible.

Because of the long lead time in developing and debugging a major data base and an associated query system it is a matter of the greatest urgency that a start on the automation of Notices to Mariners in Canada begin without delay. There are three reasons for this.

(1) National integrity. If Canada does not very quickly develop an automated system for Notices to Mariners, the automated Notice to Mariners system of DMA will become, by default, the primary source of current information for mariners in Canadian waters. Although now, Canadian Notices to Mariners are primary sources and DMA notices, whether on paper or automated, can be regarded as secondary sources, this is because they are taken from Canadian notices and published with an additional delay. However as navigation by electronic chart becomes the norm rather than the exception and as DMA's automated notice system is perfected, it is not

unrealistic to expect that mariners will plan on updating their charts, electronic and paper, at sea rather than waiting to pick up written notices after reaching port. Thus even in Canadian waters mariners, including Canadian mariners, would be inclined to use DMA charts because they were easier to keep up to date. They would presumably conform to Canadian regulations and have Canadian charts on board without using them. The implications for Canadian integrity, especially in time of crisis, are obvious.

(2) Safety. It is obvious that "time is of the essence" in so far as safety at sea is concerned. This is why, as explained in section 4.1 above, Notices to Shipping are broadcast repeatedly day and night.

As previously discussed, the reason that the interactive navigation system is appealing to mariners is its capabilities for "decluttering", that is, for displaying everything a mariner needs and only what he needs. High technology keeps providing better widgets, radar, low drift gyro compasses, LORAN-C, Doppler satellite positioning, yet, although the magnetic compass has been demoted to a remote location, nothing else has been removed from the bridge. To sail with safety the mariner must look at his chart then at his radar then at his ship's log, then from time to time he must get an independent position fix either by visual sighting or by plotting a LORAN-C, an Omega, or a satellite position fix on his chart. On the high seas he has time for all this, but in narrow channels or in heavy traffic sectors there is the risk of failing to notice some important item, thus it is not surprising that he is welcoming a device by which he can see in one display everything that he needs to see.

"Real time" is new jargon meaning that there is no significant delay. It differs from instantaneous in that delays of seconds, minutes or even

hours may be tolerated as long as there is no adverse effect. Thus in the interactive navigation system it is implicit that all the inputs must be in "real time". When the display of the radar traces and the display of the ship's position are in real time, i.e., within seconds of being instantaneous, it follows that all the electronic chart data must also be in real time. If everything the mariner needs for maximum safety is on his screen except the changes from Notices to Mariners, it is inevitable that sooner or later an important Notice that is in the manuscript file but not in the electronic chart data base will be overlooked and a major accident will occur because a change was not displayed on the screen. Real time updating of shipboard electronic charts will be essential, and for this the automation of the data base for Notices to Mariners and the appropriate facilities for transmitting it to ships at sea will be essential.

(3) Economy. In principle, mariners are responsible for ensuring that they get all the corrections for their charts and that they make the corrections to the charts. In practice, the CHS undertakes to ensure that all the charts distributed by CHS are correct to the date of distribution. Making these corrections is a full-time job for several (7 in Ottawa in 1983) people. Despite this zealous effort by CHS, many charts are held by chart dealers for months and sold without being further corrected. It is mandatory that these charts--and all other charts carried by the mariner--be kept up to date; traditionally this is one of the duties of the second mate and a most unenviable job it is. Chart updating is a task that cries out for automation. By the traditional methods it is always in arrears. Even if the quartermaster makes the corrections the moment he receives them, the chart will be at least three weeks in arrears (see section 4.2); this is because the cut-off date for entries to the Notices

is two weeks prior to the mailing date. Thus even if done meticulously, the present method is not fully effective. Quite apart from this defect, the task is tedious, it is prone to human error, and it is costly.

As mentioned above, there are several CHS staff full time on updating the stock of maps in the CHS stockroom; there are some conscientious dealers who do employ staff to update their stocks, and there are the countless ship's officers who labour over the shipboard charts. In addition to the manpower, there are direct costs, such as postage, estimated at a quarter of a million dollars per year.

In time, it is inevitable that an automated query system will evolve in Canada; it will most likely be along the lines of the DMA system whereby mariners can query a Notices data base at any time from any location and get the updating information that they need. There will be an interim period when the data will be printed out and the paper chart will be corrected by hand, but undoubtedly the time will come when, as illustrated on Figure 4.3, the Notices will be either interactively or automatically merged with the shipboard electronic chart data base. Following each such update, the conscientious mariner would get a paper copy of the changes to verify that the changes were correctly made, but at no time would he make corrections by hand. Even allowing for the cost of the hardware, this method cannot but be much less costly than the present labour-intensive method.

4.5 Updating for the Electronic Chart

In the discussion of safety in the preceding section, it was shown that, as interactive navigation systems mature, the weak link--the Achilles heel--will be the delay in keeping the electronic chart data base up to

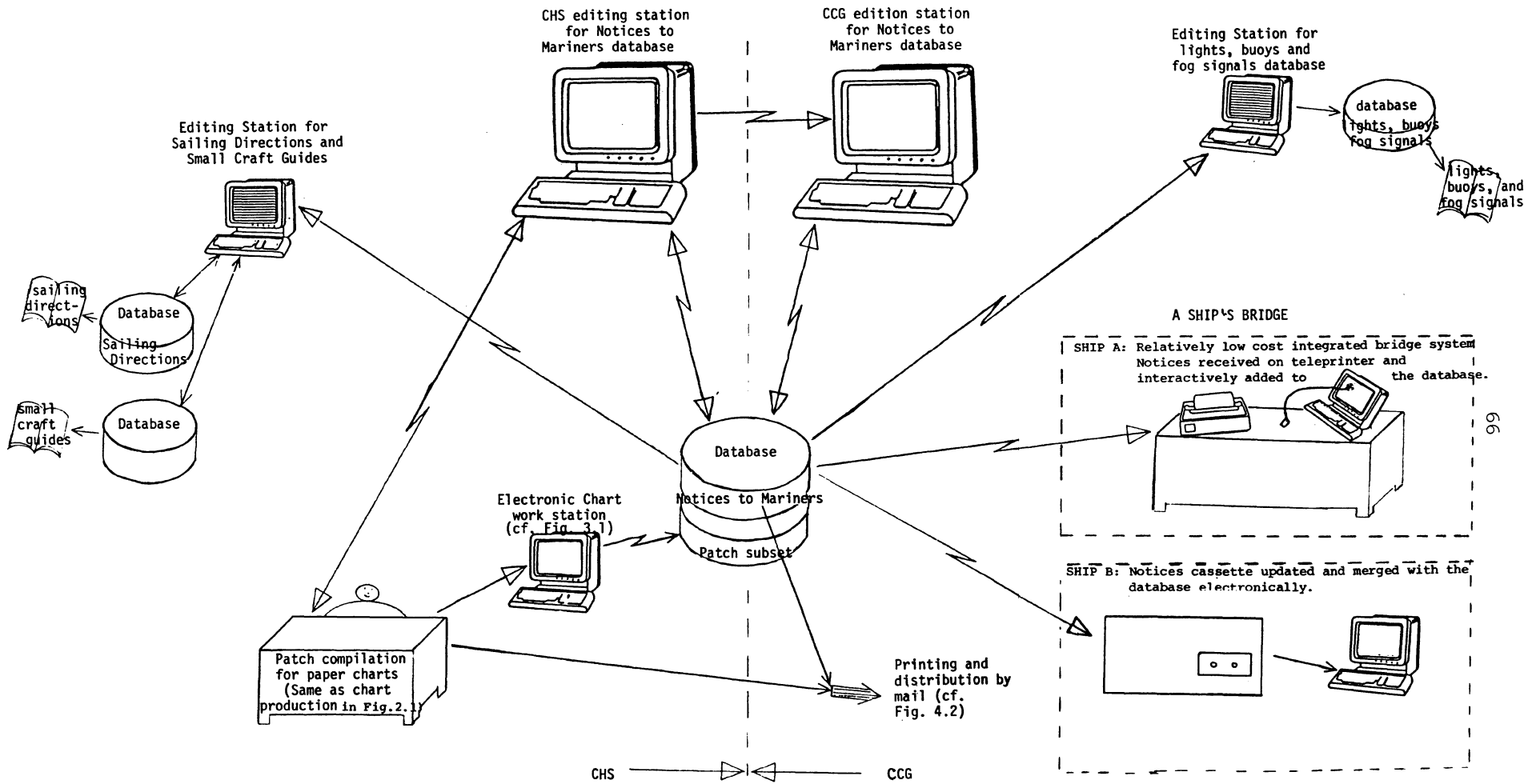

FIGURE 4.3 Conceptual flow of information to the first generation of mariners using the Electronic Chart. Up-to-date paper charts, printed copies of Sailing Directions and Lights, Buoys and Fog Signals will still be required.

date. This, along with the need to achieve economy, gives two strong arguments in favour of proceeding with development of automation for Notices to Mariners in Canada.

In Figure 4.3, a conceptual flow chart for an automated Notices to Mariners system indicating the linkage to the electronic chart data base on board ship is shown.

It is implicit that there are many institutional and technical problems to be addressed in proceeding with the development of an automated system for Notices to Mariners in Canada, nevertheless *it is our conclusion that the requirement for an automated Notices system is one of the major impacts that the advent of the electronic chart will have on the Canadian Hydrographic Service.*

5. STANDARDIZATION

The form, content, symbolization and other properties of the CHS nautical charts have evolved slowly, conservatively, and generally in accordance with the resolutions agreed upon by the International Hydrographic Organization. It is inevitable that there will be some differences between new charts and older charts and between CHS charts and those of other nations. These differences, however, are minor compared with the differences between electronic chart symbolology used for navigational aids (see Table 5.1) and paper chart buoy symbolology (see Figure 5.1). Differences in the colour used by interactive navigation systems to display different features is also evident (e.g., VIEWNAV uses red for radar returns; Tokyo Keiki (ANCDS) uses blue). These differences are in addition to the large difference in information content of electronic charts compared to paper charts discussed in Chapter 3. The question then arises as to which differences have consequences sufficient to warrant efforts at standardization.

Two categories of standardization are evident. One category is standardization of symbolology and colours used by the shipboard display; the other category is standardization of the electronic chart data bases. A discussion of each follows.

Standardization of symbols and colours used by the shipboard display:
As consistency of symbols and colours is of concern to all mariners, there are several national agencies, such as the CCG and the CHS, that are concerned with the standardization of symbols and colours. At the international level there are several organizations, such as the IMO (International Maritime Organization) and the IALA (International

Table 5.1 Examples of Symbols Used for Nav aids
by Interactive Navigation Systems.

<u>System</u>	<u>Symbol</u>
CAS _{TM} II	+ or X (primary (fixed), secondary (floating))
COMDAC	🏠 123
VIEWNAV	🗺️ (coloured e.g. red, green)
HICANS	▼
ANCDS	□
Furuno	■ or ◆ or ◆ (user selectable, coloured)
JRC	X or X
TI 8000	+ or X (navaid or hazard)

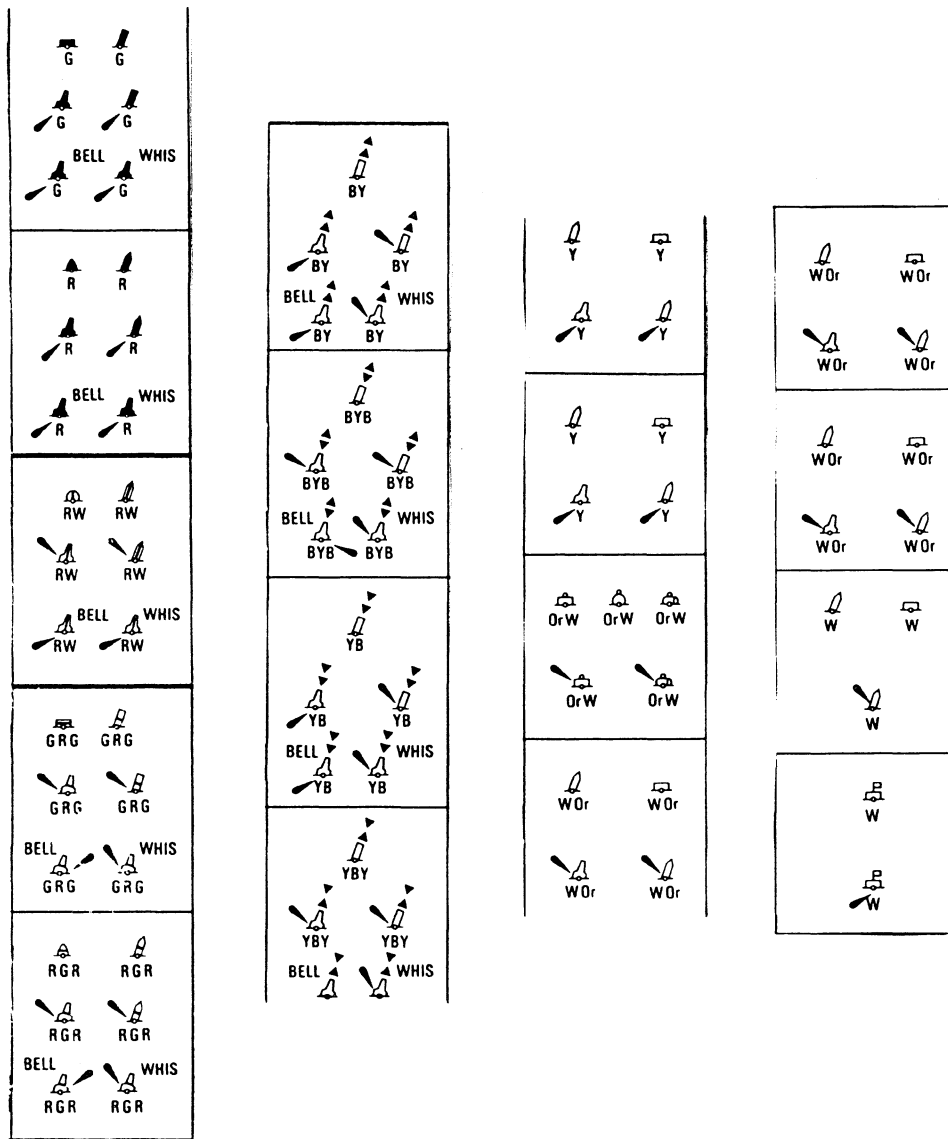

Note: All shapes  are nautical purple in the original.

Figure 5.1 Present CHS Chart Buoy Symbols

Association of Lighthouse Authorities) as well as the IHO (International Hydrographic Organization) concerned with and having some responsibility for standardization of nautical charts.

Standardization of electronic chart data bases: As CHS has a large investment in the existing nautical chart data base and because it will soon have a sizable investment in the electronic chart data base, standardization is extremely important to the CHS. Thus there is a strong incentive for the CHS to promote standardization as vigorously as possible.

Three basic questions about data base standardization must be answered. They are:

- (a) What data or feature types must be included in the electronic chart data base?
- (b) Within each feature type, what distinctions are necessary?
- (c) What format (e.g., size of data blocks = 5' x 5'?) should the data base have?

Specific questions arising from these basic ones are:

- (a) Which categories of navigational aids should be identified?
- (b) How is the positional accuracy of floating navigational aids captured and conveyed?
- (c) How is the accuracy of depth contours captured and stored? One can easily visualize a mariner displaying data digitized from a 1:30,000 chart at a scale of 1:5000 if no restrictions are imposed on the use of the data.
- (d) What units should be used for shoal lines (i.e., feet, fathoms, or metres)?
- (e) At what density should shoreline and shoal lines be digitized (e.g., 1 point per mm)?

- (f) Which shoal lines should be included (e.g., 5 m for fishermen, 10 m for merchant marine, 30 m for supertankers)? It is important that each shoal line be specifically identified so that any one shoal line by itself can readily be retrieved from the data base.
- (g) Should all soundings be omitted?
- (h) Should a shoreline be included when it is not a radar feature?
- (i) Is a low tide and high tide shoreline necessary?
- (j) What criteria should be established for the identification of radar features?
- (k) What structure (i.e., polygons (areas) or line features) should be used to represent radar features?
- (l) Should there be several families of radar features for each coastline (e.g., one for ships 2 miles from shore and one for ships 10 miles from shore)?
- (m) What units should be used to store feature coordinates (e.g., 0.1")?

Question (c) above points out the necessity of a geographically referenced data base structure for the electronic chart. Only one representation of a shoal line should exist for any area. If it is being displayed at a scale of 1:5000, and was originally digitized from a 1:5000 scale chart, it will show as a fairly smooth line. If it was digitized from a 1:50,000 scale chart, it will show up as a very jagged line, provided that both charts were digitized using the same data density. This would provide a visual warning to the mariner that the shoal line may not be exactly as indicated.

Two examples of existing data base definitions are the ARINC (Aeronautical Radio Incorporated) Specification 424-1 and the NOS/AIS format specification documents 1908 and 1909. The ARINC specification

defines the "Navigation System Data Base" used by the air transport industry for the preparation of airborne navigation system reference data tapes. The Boeing 767s being flown by Air Canada have their navigation data encoded according to their specification. NOS documents 1908 and 1909 set down the data base specifications used by their Automated Information System (AIS) (see section 2.2).

ARINC specification 424-1 was adopted by the Airlines Electronic Engineering Committee on June 17, 1980 and defines such things as:

- (i) Nine track tape should be used for master tape files.
- (ii) Data should be encoded at a bit density of 1600 bits per inch.
- (iii) Data should be encoded in the IBM Extended Binary Coded Decimal Interchange (EBCDIC) code.
- (iv) A ninth bit should be added to each eight-bit character byte encoded so as to render the parity odd.

Very detailed specifications on the organization of the characters within each record of each section of the data base are also given. The document contains 105 pages, including a 17-page supplement.

An organization, such as the International Hydrographic Organization (which already has a subcommittee to investigate the future design of nautical charts), should define a proposed standard for both the bridge display and the electronic chart data base. This could then be distributed to member countries for comments and suggestions.

If worldwide standardization of automated Notices to Mariners is achieved, automated updating of the data bases for interactive navigation systems will develop relatively quickly; without standardization, the automated notices receivable on the high seas will resemble a "tower of Babel".

6. FINDINGS, CONCLUSIONS, RECOMMENDATIONS
AND IMPACT STATEMENT

FINDINGS

- (1) Video navigation plotters and associated adaptors, linkages, and interfaces to the other components of interactive navigation systems, are being manufactured in quantity and used widely to provide mariners with an electronic chart.
- (2) Manufacturers and mariners are presently digitizing existing paper nautical charts for use in these systems.
- (3) The electronic chart data bases currently in existence differ significantly from the digital data bases for CHS paper charts in that
 - (i) The present electronic chart data bases do not include many of the features in the CHS digital paper chart data base, specifically:
 - soundings
 - depth contours other than shoal lines
 - topographic contours
 - all of the fine coastline detail.
 - (ii) The present CHS digital data base for paper charts does not include some of the features that are in all of the electronic chart data bases; most significantly, it does not include floating aids.
 - (iii) All of the electronic chart data bases are stored online in geographical (latitude/longitude) coordinates (e.g., all data for one 5' by 5' block stored in one record) with only one

coordinate definition for each feature, i.e., completely chart independent. This is in sharp contrast to the CHS digital data base for paper chart production which is entirely chart oriented where the data is stored as X,Y digitizer coordinates and more than one coordinate definition of a specific feature may exist if there is more than one chart scale representing the same geographical area.

- (iv) From discussions with officials of the Japanese Maritime Safety Agency, it is apparent that they have concerns about the impact of the electronic chart similar to the concerns identified in this report.

CONCLUSIONS

- (1) The electronic chart and the interactive navigation system which makes it possible is a major breakthrough in marine navigation the success of which is inevitable.

This is because, for the first time since high technology began producing aids for the mariner (e.g., gyrocompass, radar, LORAN-C) rather than adding to his information overload the interactive navigation system relieves the mariner of the time-consuming and mentally demanding task of collecting data from several sources and enables him to concentrate on navigating his ship safely.

- (2) The CHS should accept the responsibility for providing up-to-date nautical chart information in electronic form suitable for use in modern interactive navigation systems.

This is necessary because

- (i) The CHS has a mandate to "distribute nautical charts... required to permit safe navigation by all users of navigable waters in Canada".
 - (ii) Regulations under the Canada Shipping Act state that "every ship shall have on board...the latest edition of the CHS charts" and "shall ensure that any chart...is corrected up to date".
 - (iii) When interactive navigation systems become the norm rather than the exception in navigation, the intent of the regulation ((ii) above) will be thwarted. This is because, from a safety aspect, only what is displayed on the CRT will contribute materially to the safety of navigation in Canadian waters. To facilitate the display of correct up-to-date data and hence the safest possible navigation, the CHS must make the data base for the display available.
 - (iv) If the CHS does not provide a correct up-to-date electronic chart data base, countless unofficial ad hoc variations will appear, the intent of the regulation requiring correct up-to-date charts will be thwarted, and the relevance of CHS charts and hence of the CHS itself will be diminished.
- (3) A data base for the electronic chart should be created and maintained quite separate from the digital data base for the production of paper charts. This is because
- (i) Only a very small percentage (4% for the Atlantic region) of the paper charts currently have a digital data base. At current production rates it will be the year 2000 or later before there is a digital data base for all the paper charts.

- (ii) The electronic chart data base will have to be kept up to date on a daily basis whereas corrections for updating a paper chart can be stockpiled until that chart is to be revised.
 - (iii) The end product is quite different. Only a small percentage (less than 10% is a preliminary estimate) of the digital data for a paper chart is needed for an electronic chart. Other differences are noted in the findings above.
- (4) The requirement for an automated Notices to Mariners system is one of the major impacts that the advent of the electronic chart will have on the Canadian Hydrographic Service. It is expected that in the electronic chart era an automated Notices system will contribute to safety and it will, in time, be more economical.
- (5) Standardization of both the display of the electronic chart (e.g., colour scheme and symbology) and the information content of electronic chart data bases should begin immediately. Never before has the need for international standardization been so clearly presented to the marine community prior to countless independent standards being adopted. A set of standards (similar to the ARINC specification 424-1 for aircraft electronic charts, spelled out in the Workshop report) should be proposed now before major hardware and software commitments are made in many different systems for both the production and display of electronic chart information. Electronic chart systems are still in their infancy, and consistent worldwide electronic chart presentation would undoubtedly lead to improved maritime navigation safety and to faster acceptance of their presence on the bridge.

RECOMMENDATIONS

- (1) It is recommended that an evaluation project be undertaken for "proof of concept" and to determine answers to the following questions:
 - (i) What is the density of coastline data necessarily digitized for both harbour/channel and arctic navigation?
 - (ii) What is the density of shoal line data necessarily digitized? Are there two different densities required (i.e., one for harbour entrance/channels; another for non-harbour channel areas)?
 - (iii) What should be used for shoreline? Is the tidal area to show up?
 - (iv) What is the solution to the problem of having many different types of shoal line (e.g., 18 feet, 30 feet; 3 fathoms, 6 fathoms; 5 m, 10 m) on adjacent charts which must be combined to form the electronic chart?
 - (v) How long will it take to digitize one harbour area for this electronic chart data base?
 - (vi) What are the problems in capturing radar features for inclusion in the electronic chart data base?
 - (vii) What, if any, are the problems of a clutter of buoy symbols masking the coastline when the chart scale is decreased to, e.g., 1:200,000 using the same data displayed at 1:30,000?
- (2) It is recommended that planning for the development of an automated Notices to Mariners system proceed without delay. As the first step all personnel with significant roles (administrative or operational) in the production of the Notices and the related publications (Sailing Directions, Small Craft Guides and Lights, Buoys and Fog

Signals) should be involved in either a task force or a workshop.

IMPACT SUMMARY STATEMENT

The expected impact of the electronic chart on the Canadian Hydrographic Service is that its principle product, the paper nautical chart which has been at centre stage in marine navigation for centuries, is being relegated to the role of understudy to the electronic version of the nautical chart.

BIBLIOGRAPHY

- Canadian Hydrographic Service (1979). Role of the Canadian Hydrographic Service. 2nd ed.
- Bass, G.R. (1981). A geographic coordinate database approach to nautical chart compilation: The National Ocean Survey Automated Information System. Proceedings of the 20th Annual Canadian Hydrographic Conference, Burlington, Ontario, pp. 93-97.
- Hamilton, A.C. and S.E. Masry (1980). A review of alternatives for managing arctic hydrographic data. Department of Surveying Engineering Technical Report 81, University of New Brunswick, Fredericton, N.B., 89 pages.
- Hamilton, A.C. and B.G. Nickerson (1983). The electronic chart. Department of Surveying Engineering Technical Report 102, University of New Brunswick, Fredericton, N.B., 45 pages.
- Oswitt, R.P. and G.S. Steinfort (1983). The Command, Display and Control (COMDAC) system for U.S. Coastguard cutters. Proceedings of the American Institute of Aeronautics and Astronautics /SNAME/ASNE, 7th Marine Systems Conference, New Orleans, LA.
- Puckett, L. (1982). "HICANS-Navigation for high speed ships." Proceedings of the (U.S.) Institute of Navigation National Marine Meeting, Cambridge, MA, October, pp. 32-41.
- Sinclair, R.E. (1981). The evolving capability for automated production of hydrographic products at DMAHTC. Proceedings of the 20th Annual Canadian Hydrographic Conference, Burlington, Ontario, pp. 17-25.

LIST OF CONTACTS MADE
DURING THE
"STUDY OF THE IMPACT OF THE ELECTRONIC CHART
ON THE
CANADIAN HYDROGRAPHIC SERVICE"

1. Brian Hanley and
Capt. John Mallard
Raytheon Marine Co.
New Hampshire
U.S.A.
(603) 668-1600
Reference RAYCAS 5 or
JRC NWU-50A
2. John Volpi
Texas Instruments Marketing
Lewisville, TX
U.S.A.
(214) 462-4957
Reference TI 8000
Integrated Marine System
3. (a) Frank Soccoli
Sperry Corporation (Marketing)
Great Neck, NY
U.S.A.
(516) 574-1761
Reference CASII with
channel navigation option
- (b) Charlie Owston
Sperry Rockland (Marketing)
Highway 17
Rockland, Ontario
K0A 3A0
(613) 446-6011
- (c) Harrold Ferrell
Sperry Marine (Engineering)
Charlottesville, VA
(804) 973-0100, ext. 234
Reference CASII channel
navigation option
- (d) Lanny Puckett and
Fred Penar
Sperry Corporation (Electronic Systems)
12010 Sunrise Valley Drive
Reston, VA 22091
U.S.A.
(703) 620-7086 (Lanny)
620-7105 (Fred)
Reference HICANS or COMDAC

4. Capt. R.P.E. (Rodger) Miners
Director, Flight Technical
Air Canada Base 25
Montreal International Airport (Dorval)
Montreal, P.Q.
H4Y 1C2
(514) 636-2775
Reference Boeing 767
navigation
5. Gregory R. Bass,
Lt.Cdr. NOAA Corps
U.S. Dept. of Commerce
National Oceanic and Atmospheric Administration
Marine Data Systems Project
Rockville, MD 20852
U.S.A.
(301) 443-8874
Reference NOS/AIS
6. Mortimer Rogoff and
David S. Julyan
Navigation Sciences, Inc.
6900 Wisconsin Ave., Suite 301
Bethesda, MD 20815
U.S.A.
(301) 951-5225
Reference VIEWNAV system
7. LCDR Gary Steinfort
COMDAC Project
VITRO LAB
14000 Georgia Ave.
Silver Spring, MD 20910
U.S.A.
(301) 871-3393
Reference COMDAC system
8. Capt. John Hammer and
Mr. Bob Beaton
Defense Mapping Agency
Hydrographic Topographic Center
Washington, DC 20315
U.S.A.
(202) 227-3112 (John)
227-1364 (Bob)
9. Kinji Iwasa, Director
Shigeki Kuramoto, Planning Division
Kunikazu Nishizawa, Coastal Survey &
Cartographic officer
Hidetoshi Ueda, Notices To Mariners
Division
Masayosi Yamaguti, Oceanographic Data
& Information Division
Kunio Yashima, Planning Division
Hydrographic Department
Marine Safety Agency
3-1 Tsukiji, 5-Chome, Chuo-Ku
Tokyo 104 Japan
Reference Hydrographic
Department's response to
the use of electronic
chart data.

10. Gen-Ichiro Tomioka, General Manager,
Navigation & Super Sonic Equip.
Chogo Sekine, Asst. General Manager,
Second Engineering Dept.
Japan Radio Co., Ltd.
Mitaka Plant
5-1-1, Shimorenjaku 5 Chome
Mitaka-Shi
Tokyo 181 Japan
- Toshishaburou Kawana, Marine Electronics
Section II
Japan Radio Co., Ltd.,
Foreign Trade Department
Akasaka Twin Tower
17-22, Akasaka 2 Chome
Minato-Ku
Tokyo Japan
- Reference Japan Radio Co.
Ltd. colour video plotters
and total navigator
11. Yasuo Ogo, Assistant Chief,
Section II
Furuno Electric Co. Ltd.
International Division
No. 9-52, Ashiharo-Cho
Nishinomiya-City, Japan
- Reference Furuno GD-200,
GD-170 and Navguide 1000
12. Y. Hiraoka, Manager
Marine Sales Dept.
Tokyo Keiki Co., Ltd.
Nihon Seimei Gotanda Bldg.,
31-1 Nishi-Gotanda 1-Chome
Shinagawa-Ku
Tokyo 141 Japan
- Reference ANCDs for
Hydrographic Dept.
13. Minoru Nagatani, Managing Director
Motoji Kawanabe, Staff Member
Japan Hydrographic Association.

APPENDIX I

THE ELECTRONIC CHART

R.M. Eaton, N.M. Anderson, T.V. Evangelatos
Canadian Hydrographic Service

A paper presented at the Canadian Hydrographic Service
Centennial Conference, Ottawa, 6-8 April 1983.

PREFACE - A Navigation Day-Dream

Imagine the scene on the bridge shortly after the year 2000. Newfoundland and the federal government have recently reached agreement on offshore resource ownership, and the tanker, "Concord Yemani", light out of Bahrein, is crossing the Grand Banks en route to Come-By-Chance. At 2200 that night the second mate is on the bridge getting the consolidated Notices to Mariners for the Atlantic coast by telex from St. John's radio; he records them on a diskette which he loads into the Electronic Chart Storage Controller, and thus automatically updates the chart data in storage. The Captain comes out of his sea cabin, and notes that on the real time chart video display there is a strobe flashing on the Virgin Rock, with a warning that on the present course and speed made good the ship will pass within 2 miles of the 30 m contour in 18 minutes time. The mate on watch assures him he is keeping an eye on this while he manoeuvres to clear a group of draggers, and as has become quite a habit with him, he again comments on how useful it is to have the NAVSTAR/LORAN driven electronic chart look after position plotting, leaving him free to concentrate on avoiding collision. The Captain is satisfied, and goes to the auxiliary video display and calls for the ephemeris to display tomorrow's time of sunrise and sun's true bearing (for a gyro check), followed by tides for the day computed from harmonic constituents included in his Atlantic coast chart disc. He also checks "S.D." for details of reporting and traffic regulations for Come-By-Chance. Then he calls up the Chart 1:5,000,000 and zooms the scale until the Bay fills the screen. He superimposes fishing areas in green and traffic control zones in purple, then erases them to have a clearer look at the depths. As he scans over the chart up to Come-By-Chance, enlarging the scale as he goes, he finds he cannot go above 1:24,000 for the outer approaches as that was the scale of the original survey. The Captain uses the

"track-plan" routine to put on his courses for the next day. He selects a 10m keel clearance and 5 cables lateral clearance; flashing danger strobes come up on a couple of points where these are not satisfied. Once he is happy with his planned track he transfers it to the chart controller so that it will appear on the real time plot when the ship reaches that area.

As the ship rounds Cape St. Mary's next morning and approaches Argentina traffic control, the mate on watch superimposes the digital radar output in green on the chart video display, and by radar joystick he matches the radar coastline to the chart coastline, thus removing a small residual ASF correction in the Loran-C that is driving the ship position. He confirms at a glance that there are no islands three miles ahead up the coast, so these radar echoes must be fishing boats. As the ship nears Argentina they pick up the shore radar re-broadcast, and superimpose that video image on the chart in orange to keep track of other ships in the vicinity not yet on their own radar. At the same time the captain puts the "track profile" on the auxiliary display; this shows a graph of the under-keel clearance along his planned track, with the ships sonar graph superimposed.

An hour later, in preparation for berthing at the loading dolphins, the Captain locks on the differential Loran-C monitor for maximum accuracy with respect to the dock, and switches the real time display to docking mode. At a scale of 1:1,000, (no soundings) this shows the ship 15cm long, making it easy to judge her orientation and distance from her berth.

Mr. Smallwood is first aboard the ship when the gangway goes down.

The Electronic Chart Is Coming

As we celebrate the 100th Anniversary of the Canadian Hydrographic Service and look back to the beginning of the Service

and the ways and means used to collect data and present it to the mariner, it is equally of interest and of value to look ahead to where we are going. The nautical chart has evolved from a map showing the shoreline and prominent features and depths along navigation tracks, to the depth contour, more shoreline information, and then the cultural features as settlements developed. Today, the nautical chart is a comprehensive document showing not only detailed depth contours, and the shoreline and the foreshore information, but also considerable additional navigational aid information which may be relevant to navigation, notes about the tides and currents, harbour information, etc. As the chart has evolved it has become more cluttered with information; consequently the challenge to the cartographer is to show more and more and more information on a document which is limited in scale and size. This necessarily means that at some point information has to be dropped to make space for other higher priority information. It means that colours need to be used, symbols need to be developed to graphically show more information in a small space, and that eventually special purpose charts are required. Charts for offshore navigation, recreational charts, fisheries charts, etc. are examples.

On the bridge of a ship the nautical chart today is an important document for navigation, for recording the tracks of the ship, and to carry the additional notes that a mariner or fisherman may add to his chart relevant to his particular mission. The nautical chart as it is now will continue to be used for many years into the future. We are not suggesting that the nautical chart will cease to exist in the near future. However, it does have limitations, and current technical developments can possibly be applied to mitigate these.

Television today is an important form of information transfer, and along with television a whole array of new developments are occurring showing the direction of the future in terms of using

the electronic technology to show visual information. For example, you do not go very far today without seeing an arcade with video games. Well there are other applications, less profitable perhaps but nevertheless more practical, of the same video technology. For example, Ford Motor Company is now demonstrating a video map which is placed in the car and keeps track of the car's position relative to the map and shows the driver where he is within the streets of the City. Texas Instruments have developed simulators and are in the process of developing equipment for the video display of digital terrain models of the earth so that the pilot in the cockpit if he loses his view of the ground, has a digital version of the terrain shown to him on the video display within the cockpit.

A year ago we field tested a Japanese video plotter attached to a Loran-C receiver onboard C.S.S. "Dawson". It had a 30 cm screen, and displayed the ships track from Loran-C on mercator projection at any scale from 1:10,000 to 1:1,000,000 adjustable instantly by zoom control. Way points entered in the Loran-C receiver microprocessor were displayed on the plotter, and the operator could tag points on the plot by various symbols positioned by a cursor. The plotter stored several hours of track in its own memories, and these could be backed off onto a cassette recorder to be stored for replaying onto the plotter at a later date. The most impressive demonstration of its usefulness came when the release of a seabed transponder failed, and the ship had to drag for the mooring. The ships track when laying the transponder and its 600m ground line was replayed onto the plotter at 1:10,000 scale, and with this it was child's play to control the ship in dragging for the ground line and when that parted, successfully grappling the mooring itself. It was successful because the Captain had an immediate, continuous, complete, record of the ships track, without plotting a single fix. He had plenty of time to manoeuvre the ship, keep an eye on work on deck, and watch the radar for other traffic, because he did not have to dive for plotting sheet every minute to update the ships position.

The video chart is not a new idea. Some years ago Sperry (Tiblin 1977) added chart information to collision avoidance radar (there is no point in substituting a grounding for a collision). The

U.S. Coast Guard are evaluating video charts now. (Puckett H. 9278, Erickson 1982). Companies such as Texas Instruments and Navigation Sciences Inc., of Washington D.C. have done contract and in-house research on electronic charting (figure 1.)

What is the electronic chart? Is there a firm definition of the electronic chart at this time? No, it is too early to see what the end product will be. The term is for discussion purposes only. At its most elementary level it could be envisioned to be that information which is used on a video display where the Loran-C position and the radar are integrated and some shoreline information is added to the display, possibly also containing some navigational way points. At its most comprehensive level, it can be envisioned as a digital data base of the bathymetry, other navigational information, shoreline, sailing directions, nautical publications, Notice to Mariners and that the data manipulation system has the ability to zoom in on specific information, select certain information, integrate computations from several sensors compare measured depths to the depths in the digital data base or project cause and identify possible hazards, etc. Its development will depend on the pace of technological advances; on the introduction of Navstar GPS as a universal, precise navaid; and on shipowners and legislators of being convinced that it will make navigation safer and more efficient. In this paper we would like to show how the electronic chart can help the mariner and to discuss the impact of advancing technology on the electronic chart. We do this with the idea of generating discussion rather than laying down a cut and dried programme.

Features of the Electronic Chart

No one supposes the Electronic Chart will simply arrive in 1990, fully developed and with every imaginable feature. Instead it will evolve from the present limited starts, and at anytime different versions will have as much variety in features as there are in automobiles. However there are some basic features which will be common to all electronic charts, and we will consider those after making a general comparison with paper charts.

90

In concept at least, the electronic chart has advantages over paper charts. One is flexibility the ability to move from one part of the ocean to another by slewing a joystick, or automatically following the ship, and to zoom the scale by pressbutton control. Perhaps the most important is the ability to display the ships' position on the chart, and to maintain a continuous plot with the full accuracy of whatever nav aids are being used. The navigator can see at a glance where he is, without putting his head into the chart table and plotting a fix, and he will be able to compare the radar directly with Loran-C/Decca/Navstar G.P.S., and so solve positioning inconsistencies. Another difference is that the video display can be animated, to put a red flasher on a navigation hazard; to show a pulsing blue wave on a tide rip; to show the track of bergs and growlers. It can be programmed to display notes at appropriate times; for example that "strong tidal streams occurs three hours after high water i.e. at 1997/03/04007".

The video display also has drawbacks. The resolution is not as good as on paper. (but it is arguable that the display should be kept bold and uncluttered so that it can be assimilated quickly.) All chartwork at present done by pencil and parallel rule will have to be done electronically on the display (but that should cause the new generation no trouble.) If a component fails you lose the chart (but you can also lose radar and the ships steering gear). Perhaps the greatest problem will be that flexibility has an inevitable twin - complexity; it will be vitally important to make the electronic chart user-friendly, and to have some international set of uniform standards and procedures.

The electronic chart system comprises a great many features. Here are some of them, starting with the video display:

The Video Display of the Chart

The projection can be a choice. The computer will generate rhumb lines or great circles, so Mercator or Gnomonic are not essential.

The scale can be varied from very small (which requires that the computer generalize the data) to very large. However the scale of the original survey must not be exceeded, or if there is good reason to exceed it, this fact must be flagged, perhaps by pecking or blurring the lines. Evidently the data base for such a chart has to cover the area of the smallest scale chart and yet have the detail of the largest scale - a formidable problem in data storage and manipulation.

Because the resolution is less than that of the paper chart, less data can be displayed and some selection will be necessary. But critical features such as shoreline and conspicuous objects, shoals, critical depth contours, fixed and floating aids, power cables in anchorages etc, must always be shown.

Optional data should be available on demand. A minimum set for a complete electronic chart is everything on the paper chart, grouped under classifications such as "depth contour," "type of bottom", "tides and currents", "traffic control" etc. Other features not always on the paper chart, such as "special fishery information", "main shipping routes"; "distribution of iceburgs for the month of June", could be added for display one at a time.

Survey data recorded on NAD 27 datum should be transformed to WGS '72, if necessary by the electronic chart itself.

Displaying the Ships' Position

Video plotters are already driven from TRANSIT SATNAV plus log and gyro, or by LORAN-C etc. The continuous track they generate is a great advance over occasional hand-plotted positions in detecting gross errors, or the effect of currents, etc.

To equal the accuracy of the paper chart, Loran-C fixes must be corrected for land - path errors.

A visual fix by cross bearings (or range and bearing) could be plotted by putting a cursor onto the object and entering the range and bearing on the control panel; this would display a range arc and bearing LOP on the video.

It is fundamentally important that the electronic chart is integrated with the radar display, preferably by superimposing a digitized radar image (with brightness control) on the chart video. This will help to identify radar targets, especially when the shoreline is low or masked by sea ice, and will distinguish between radar echoes from buoys and from other ships. By joystick control, the radar image (and the ships position that goes with it) can then be moved to correspond with the shoreline, thus eliminating residual errors in the radio navaid, which will thereafter serve to keep the radar on the target by dead-reckoning the ship along the track. The OOW can check at a glance that this is in fact happening.

Making Chart Corrections

The basic chart data must be on a protected, read only, memory; this will be revised when major changes occur, just as a paper chart is reprinted. Automatic chart corrections will be applied from a temporary correction memory which the mariner replaces each time he obtains a fresh set of corrections.

Planning a Passage

Instead of using a pencil, parallel ruler, dividers, and a whole chart folio, the mariner will plan a passage by first zooming down to a scale small enough to show both the port of departure and the destination, and run the track cursor along the proposed passage in order to read out total distance and given speed, the time on

passage. Then he will increase scale and re-frame the chart to cover the first leg of the voyage and put a cursor at each end of the first leg. The computer will draw a line between, and in a sophisticated model chart, it will flash any hazards within a selected distance of the track. After displaying and checking auxiliary information such as tidal streams and fishing vessel concentrations for that time of year, the mariner presses "hour" to generate ticks at one hour intervals along track, and then "store", which records the track on the passage diskette, which can then be filed until the ship sails. Once that route has been proved satisfactory, the passage diskette can be reused indefinitely.

Ephemerides

In a sophisticated model, navigation programs can be selected from a wide range, and an annual ephemeris tape will update sight reduction calculations; compute time and the sun's true bearing at sunrise and sunset; compute tides from stored tidal constituents; etc. Similar programs will provide magnetic variation; Omega diurnal correction; geoid height for Transit Satnav corrections; geographic datum transformation etc.

Track Record

In addition to a continuous record of ships position, the electronic chart logger could record the scale used and class of information being displayed at any time, plus a digitised radar picture at intervals. Stored in a sealed unit "black box" this would be a more reliable record than a pencil track on a paper chart plus pencil entries in the ships' log.

The Hardware Technology

The hardware that could be used to build an electronic chart is more or less available now. The cost of the hardware alone is probably still too high to make such systems attractive to many users. The cost of developing general purpose software is also very high at this time, but with current and predicted reduction in hardware prices of over 20% per year, it should not take very long for the cost of the hardware components to reach a reasonable level. The foundation of the software is being laid through the construction of special purpose systems and from the progress being made in computer-assisted cartography and hydrography.

The major components of the electronic chart as currently visualized are:

- Microprocessor central processing unit (CPU)
- Data storage medium
- Electronic display
- Radar and positioning systems

Microprocessors

Today's lowcost computer is typically an 8 bit microprocessor with a capability of executing around 1/2 million instructions per second. Such a chip sells for about \$5.00. Chips that can run up to 10 times faster are now available at slightly higher cost. By 1985 it is predicted that the 8 bit microprocessor will have been supplanted by the 16 bit chip or 32 bit. The major obstacle in moving to the larger chip is not the extra cost of the hardware but the very large variety of existing and relatively inexpensive (often free) software for the 8 bit units. Current 32 bit microprocessor chips range from \$400 up and we expect the electronic charts will be based on this technology. Of course to the cost of the chip must be added memory and hardware to control the various peripherals and perform other functions; the cost of the chip is only a small part of the overall computer system cost.

The striking decrease in cost of the hardware for storing digital data over the past decade has been a significant factor in creating the microprocessor revolution. For some types of memory storage the costs have dropped by a factor of 100 and this trend is expected to continue for the foreseeable future.

The electronic chart will employ different types of storage. These are illustrated in Figure 2. The primary memory, packaged with the CPU, consists of a main memory and a cache. Main memory will contain the program and data currently being processed. Faster memory costs more, and the use of a high speed cache memory between the slower and cheaper main memory and the CPU is a way of speeding things up in an economical fashion. As memory get faster and cheaper, the cache may not be required. At present primary memory is constructed from semi-conductor arrays which are still too expensive for storage of very large amounts of data, this creates the need for the secondary, mass storage, memory.

The mass storage memory could probably be a magnetic disk, but in the future the optical disk may be more attractive due to its greater capacity. It may be feasible to store all the hydrographic charts of Canada on one 30cm diameter disk!

Auxiliary or archival memory is used for data that is not accessed very often. It must be reliable and relatively low cost. Although magnetic tape is typically used, this medium might not be suitable for shipboard use. A potential application of the archived memory might be to automatically log the vessel's track and any other important activity that can be monitored. In the event of an accident or other mishap the record would be available for analysis.

Electronic Displays

The specification, design and selection of the display and the operator's console will be a crucial element in the design of the electronic chart. A high resolution colour display is mandatory for a general purpose system, although single colour, medium resolution displays may be adequate for special purpose systems. High resolution means at least 1000 per line elements in each axis. Our work in computer-assisted cartography suggests a minimum dimension of 40cm square. With current technology these requirements can only be met with a cathode-ray tube (CRT) type of display. Liquid crystal and plasma displays are being developed but it will be some time before they can compete with the CRT in terms of size and resolution. Liquid crystal and plasma displays are flat, operate at lower voltages, consume less power and are more compact than the CRT display.

The CHS Technology Base

In the 1950's the CHS introduced electronic navigation and positioning to the field surveys and in the 1960's the computer was added to the field survey operations. From those meagre beginnings the use of the computer has increased to where today it is used extensively for survey computations, data logging, processing and plotting. The result is an ever increasing accumulation of digital hydrographic data.

In the late 1960's, automated plotting was introduced in CHS chart production to handle the mathematical functions such as navigation lattices and borders and grids for the nautical chart. The digitizing was developed so that graphic data could be converted into computer compatible form. The equipment that the CHS now has is flexible, interactive and is effectively used for chart production.

The introduction of interactive graphics in the late '70's was an important innovation in the chart production process because this put into the hands of the cartographer the same decision-making power that he had before in compiling the charts manually. Interactive chart compilation is now a practical process provided the cartographer has available to him the data in digital form to work with. One of the holdbacks in this process is that most of the hydrographic data base required for chart production is still in graphic form. Today we see the automated logging of digital hydrographic field surveys where the position and depth and time are recorded and processed and the field sheet automatically plotted in the field. Currently the software is being developed to handle the automated contouring of the digital hydrographic data. Charts are compiled and the compiled information is digitized, interactively edited, and automatically drawn so that the colour negatives used in the chart printing processes now are automatically drawn on high resolution plotters such as the Gerber 32 and the Kongsburg plotters. The Canadian Hydrographic Service is in the process of developing a digital hydrographic data base and a digital chart data base as a result of these ongoing production processes. The question to be addressed is whether these data bases will be appropriate for the customer who doesn't want the hard copy version of the data, but the digital data itself for an integrated navigation system on the bridge.

Radar

The mariner's first reaction upon hearing about the proposed electronic chart is that it must show the radar information. Two choices exist: attempt to overlay the radar "picture" on the electronic chart display, or alternately add the chart data to radar display; the latter would require a major redesign of the radar system, and therefore it is felt that the first method would be easier and less costly.

Two techniques to add the radar information to the electronic chart display have been suggested. The radar returns could be digitized, processed to match the scale of the electronic chart display and then added to the display. The second technique would use a scan converter to convert the radar picture to a raster display, which would also be scanned and added to the electronic chart display. Both of these approaches require investigation.

The Data Base

The electronic chart may just be a cataloguing system which simply accesses digital versions of our existing charts with their overlapping scales and limited coverage. But since the electronic chart will be more flexible than the paper chart, both in scale and in selecting certain classes of data, it is capable of containing much more information than the paper chart does. In principle it is possible to provide a completely general data base, conceivably containing all available hydrographic information. Whether this is practical is another matter. The choice between a paper chart oriented system and a general system is an important question since many years will be needed to build up the digital data base.

It is not the CHS's responsibility to research and develop the electronic chart for use by mariners. However, if we are to have a data base which will meet the needs of the future, we need lead time to begin its development and to bring it into place when the technology becomes available for the mariner. Therefore, there are certain areas in which we will conduct research, in order to give direction to our data base development. We need to know what will be required of the data base. We need to develop the procedures for

selecting and generalizing the data. We need to know what kind of symbols will be used on a video display; they will not necessarily be the same symbols used on the traditional nautical chart. We need to plan the production, maintenance and distribution of the digital chart data base. Although we do not see the electronic chart coming into full use for many years, we recognize that it is important to start to plan for it today.

The electronic chart may just be a cataloguing system which simply accesses digital versions of our existing charts with their overlapping scales and limited coverage. But since the electronic chart will be more flexible than the paper chart, both in scale and in selecting certain classes of data, it is capable of containing much more information than the paper chart does. In principle it is possible to provide a completely general data base, conceivably containing all available hydrographic information. Whether this is practical is another matter. The choice between a paper chart oriented system and a general system is an important question since many years will be needed to build up the digital data base.

Hydrographers and cartographers have only begun to use and be comfortable with computerized systems. The expertise and experience established in applying automation to hydrography and cartography will be an asset in the development of the electronic chart. We will be conducting a study to review the state of the art at determining what is happening in other offices and companies around the world, in developing and applying the technology. We will also be conducting pilot projects to provide more specific information relevant to the development and specification of the data base. A prototype electronic chart is now being planned to simulate a commercial electronic chart. The objectives of this project are to develop:

1. data base specifications
2. minimum standards for the use of the hydrographic data base
3. standard video symbols and conventions

Conclusion

Some forms of electronic charts will evolve over the next decade. The world's hydrographic offices will then face a new situation, and some new challenges. Their chart production monopoly, based on selling charts as a government service at less than cost, will disappear as industry begins to produce electronic charts. Industry will ask for a logically organised, complete, data base. If there are no guidelines, each manufacturer will make his own selection of which chart features should be shown, and his own selection of which chart features should not be shown, and his own choice of colours to identify them and symbols to portray them. In an extreme example he may eliminate everything except the shoreline, and blow up a 1:50,000 scale survey to a 1:5,000 scale display.

Issues that the world hydrographic offices need to reorganize include base format; minimum standards for the use of hydrographics data; colour code conventions for various features; and standard symbols. These matters cannot be finally settled until electronic charts have been produced and used, and even then regulations that are too strict are undesirable as they tend to stifle development. But general guidelines need to be established before bad practices become entrenched, and difficult to undo. The air industry is ahead on this, with, for example, specifications for a computer readable IFR cockpit display (ARINC 1980). We cannot establish standards before we know a fair amount about how an electronic chart will work. The studies and seminars over the past year are only a beginning, but we hope will stimulate ideas and further work in this new and exciting frontier of hydrography.

APPENDIX II

Automated Notice to Mariners
Communications Users' Manual
April 1983 (abridged)

Published by
The Defense Mapping Agency
Hydrographic/Topographic Center
Washington, DC 20315
U.S.A.

INTRODUCTION

This manual provides instructions for remote access to the Automated Notice to Mariners System (ANMS) which contains the data used to print the Summary of Corrections (updated every week) and Broadcast Warnings (updated daily). The Defense Mapping Agency Hydrographic/Topographic Center (DMAHTC) offers this service as a supplemental convenience to mariners, providing access to up-to-date navigation data. Figure 6 provides a flow chart of the ANMS. The remote access subsystem remains under development and improvements will be made for user convenience. It is not a replacement for the official weekly Notice to Mariners publication.

AVAILABLE DATA

Initially, four programs are available to the mariner (hereafter identified as user):

- (1) The Mailbox Data Entry program (job code MP01) provides a means for users to input data or messages to DMAHTC from the field.
- (2) The Summary Extract of Chart Corrections program (job code QS37) provides corrections by chart number from the current Notice to Mariners back to a specified notice number or all corrections to the current edition of a chart (i.e., all corrections since 1975 when the ANMS data base began).

- (3) The Broadcast Warning program (job code QB11) provides broadcast warnings affecting a specific (selected) geographic subregion back to a user specified date. Geographic subregions are shown on page "v" of each weekly Notice to Mariners.
- (4) The Extract of Warnings affecting a NAVAREA program (job code QB12) provides all Broadcast Warnings for a NAVAREA.

TELECOMMUNICATIONS ACCESS

The telecommunications networks providing remote access to the ANMS are as follows:

- (1) Teletypewriter (record) networks including Western Union TWX and Telex services. Any International Record Carrier (IRC) can be used through interconnections to Telex. TWX use is limited to continental U.S. TWX users only. The TWX number for the ANMS is 710-824-0551. The Telex number is 908140.
- (2) Dial-up voice networks include the U.S. domestic telephone network, the official AUTOVON service, and any foreign telephone system which interfaces with these. The U.S. domestic telephone number for the ANMS is (area code 202) 227-3351. The AUTOVON number is 287-3351 for U.S. Government users.
- (3) International users may access the ANMS on dial-up voice circuits for information. CCITT V.21 standard modems are installed on ANMS telephone lines (202) 227-3457 and 227-3458.
- (4) Ships at sea can access the ANMS data files through the INMARSAT system either via Telex or over dial-up voice circuits (which involve use of additional equipment, such as a portable, acoustic coupled data terminal).

PROGRAM STRUCTURE

ANMS programming was designed to aid the user by providing chronological prompting instructions and error messages. Once a user has entered the remote query routine, the prompts and the menu should lead the user through the individual programs. The computer responds to operator inputs only after a carriage return is executed.

OPERATIONAL/COST CONSIDERATIONS

Customers will pay the cost of each of the telecommunications networks used. To minimize cost:

- (1) Users should be prepared with all needed input data before LOGIN (e.g., this is the ANMS code word to begin a query).
- (2) All inputs should be carefully typed to avoid error messages or receipt of unwanted data.
- (3) Consider the total cost for selection of a particular communication network. Some networks may cost less per unit of time but more per query.
- (4) Ask for only the minimum amount of data required.
- (5) SIGN OFF and disconnect the terminal from the communication link as soon as the query is completed. Telecommunication networks charge for total connect time whether user is actually using the ANMS system or not.

INPUT PARAMETERS

Each ANMS task (or program) requires a few input parameters which should be determined before the communications connection is made (and charges begin to accrue). They are as follows:

For the Mailbox routine (MP01):

- (1) The code or name of the person for whom the message is intended.
- (2) The name of the originator or origin of the message.
- (3) Any references.
- (4) Write down the exact text of the message.

NOTE: The ANMS computer will automatically assign a message number for ANMS internal reference. When typing the text portion of the message, the double quote marks (") and the question mark (?) cannot be used in the message itself. The intended purpose of both of these characters is to produce a clean, clear message by allowing users to delete their typing errors. Use of the double quote mark (") will delete only the letter or character that it follows, and the use of the question mark (?) will delete everything on the same line preceding the question mark.

For Chart Corrections routine (QS37):

- (1) Chart Numbers (corrections for up to 10 charts may be requested per query; however, program QS37 may be invoked as many times as required).
- (2) Notice number and year back to corrections which are desired (note: data base began in 1975).

For Broadcast Warnings routine (QB11):

- (1) World subregion should be ascertained from chart on page "v" of any weekly Notice to Mariners.
- (2) The date back to which broadcast warnings (in force) are needed.

For Broadcast Warnings Affecting a NAVAREA (QB12):

- (1) Enter NAVAREA number, Code or type in HELP which lists areas and Codes.

(2) HELP gives the following information:

VALID CODES AND AREAS ARE:

CODE	AREA
12	NAVAREA XII
P	HYDROPACS
4	NAVAREA IV
A	HYDROLANTS

Enter NAVAREA, CODE or HELP.

(Above text is an example of a remote terminal's printout.)

(3) Once code or NAVAREA is entered, the computer asks for starting date by day, month, year (i.e., 12 February 1983).

INSTRUCTIONS FOR USE OF EACH COMMUNICATIONS SYSTEM

Telex. Any Telex terminal can be used to access the ANMS through the number 908140. Procedures for direct domestic access through the Western Union Telex service differ slightly from access relayed through IRCs. Domestic users will receive the answerback code NTMDMA BHDA if they send a WRU (which stands for "Who are you") and it is produced by pressing the "FIGURES" key, followed by the "D" key. After that, they must send a character and carriage return to initialize the LOGIN program. IRCs trigger the answerback automatically but may also send an initial message to the computer which will automatically initialize the LOGIN program. The user may then see a few garbled characters caused by the network switch and the ANMS computer simultaneously sending messages. If a LOGIN request appears clearly, the computer has already been initialized; otherwise, the user should send a carriage return for initialization. User should not proceed to the Program Execution Instructions. Figure 1 shows an example

of a query printout from a domestic Telex terminal and Figure 2 shows an example of a Telex printout from a satellite ship earth station receiver.

(Instructions for dial-up voice circuits and for TWX have been omitted in this abridged version.)

GENERAL PROGRAM EXECUTION INSTRUCTIONS

Examples of queries made by the use of several different communications links are shown in Figure 1. The following comments are general and apply to all communications links. The remote user's computer-to-terminal circuit is initialized when the following statement is received:

LOGIN PLEASE

ER!

To log-in type:

LOGIN ANMS (followed by a carriage return)

The system will respond by acknowledging the LOGIN and requesting the users to type in their unique user identification code. Users' ID's are assigned by DMA based upon a simple written request. Once the ANMS users send their assigned Identification Number, followed by a carriage return, the computer should acknowledge the identification code with a welcome statement. The ANMS computer may reject it if the transmission is not received accurately or if a typing error is made. After three rejections, the program will automatically log the unsuccessful users out of the system. If this occurs, the circuit was probably noisy or weak. Users should start over once again and repeat all the above steps (also refer to the note in the next section on procedure to handle repeat requests for data entry). Once

the computer recognizes a valid identification number, it sends the welcome statement and requests a job code. Valid job codes are:

MENU
CHART CORRECTIONS/BROADCAST WARNINGS

JOB
CODE

MP01 - MAILBOX DATA ENTRY
QS37 - SUMMARY EXTRACT OF CHART CORRECTIONS
QB11 - EXTRACT WARNINGS AFFECTING A SUBREGION
QB12 - EXTRACT WARNINGS AFFECTING A NAVAREA

ENTER JOB TO RUN; MENU TO RE-DISPLAY MENU
OR SIGN OFF TO TERMINATE PROGRAM

If the menu is selected, the valid job codes will be typed out along with the program titles. Once a job code is entered, the program will indicate the appropriate responses. When the program has finished, it will provide the user with the option to select another program, the menu, or to terminate the run. To terminate the program, type:

SIGN OFF (followed by a carriage return).

The program will acknowledge the SIGN OFF and indicate the time used. The first of the three times printed will give the total time used in hours and minutes.

TO FINISH A QUERY OR RESOLVE A PROBLEM

Noise on the telephone circuits can make data entry difficult and several repetitions may be needed. When the terminal repeats a request for data entry and the input appears to be correct, users should start their next attempt to enter the required data with a question mark (?). This tells the ANMS computer to ignore any signals received before the input data. If the computer rejects the input again, this indicates that the telephone connection is not usable. Hang up the telephone and try again

later. However, users should not terminate the circuit after a successful LOGIN unless the circuit is completely unusable because the computer communications port will become temporarily unusable to others. Users cannot terminate any ANMS program until one of the prompts indicates that SIGN OFF is an option. However, if the line is so bad that users are not able to SIGN OFF, it is correct to disconnect from the line in order to minimize costs. Users should then wait a few minutes and try again. If there is difficulty in entering data or users find that a program has been selected that was not wanted, follow through the program until it allows a recovery or until the system types out the SIGN OFF option. The ANMS operates in a full duplex mode for telephone dial-up service and the use of a control "S" will stop a long print run and allow user to SIGN OFF. If unsuccessful, users should not hesitate to try again after SIGN OFF.

Figure 1

 NTMDMA BHDA
 LOGIN PLEASE
 ER\$ LOGIN ANMS

PRIMOS VERSION 18.2
 ANMS (7) LOGGED IN AT 19:33 0033082

PLEASE ENTER YOUR USER IDENTIFICATION
XXX

WELCOME TO THE AUTOMATED NOTICE TO MARINERS SYSTEM

OK, R ANMS

ENTER JOB TO RUN OR MENU TO DISPLAY PROGRAM MENU

QS37

SUMMARY EXTRACT OF CHART CORRECTIONS
 PLEASE SELECT ONE OF THE FOLLOWING OPTIONS:

1. ALL CORRECTIONS TO SELECTED CHARTS
2. CORRECTIONS FROM CURRENT NOTICE BACK TO A SELECTED NOTICE

PLEASE ENTER YOUR SELECTION (1 OR 2)

1
 ENTER CHART NUMBER
12323

ENTER: NEXT CHART NUMBER
 OR CARRIAGE RETURN TO START PROCESSING

		AUTOMATED NOTICE TO MARINER	3/30/82
		CHART CORRECTION QUERY SYSTEM	
		EXTRACT ALL CORRECTIONS TO SELECTED CHARTS	QS-37
12323	19ED.11/15/80	NEW EDITION	4/81
			(NOS= 51/80 CG3)
	DELETE	BUOY +LE+	
		39DEG 28.2MIN N 74DEG 15.9 MIN W	
12323	19ED.11/15/80	LAST NM	4/81
			1/82
			(47/81 CG3)
	RELOCATE	BUOY (39DEG 44MIN 45SEC N 74DEG 34MIN	
		51SEC W) TO	
		39DEG 44MIN 14SEC N 74DEG 35MIN 18SEC W	
	ADD	DANGEROUS WRECK (PA)	
		39DEG 44.2MIN N 74DEG 08.4 MIN W	
12323	19ED.11/15/80	LAST NM	1/82
			7/82
			(1(43)81 OTTAWA)
	DELETE	ALL REFERENCE TO LORAN-A RATES	
		NOTE: STATIONS PERMANENTLY DISCONTINUED	

EOJ-QS37

ENTER JOB TO RUN, MENU TO RE-DISPLAY MENU
 OR SIGN OFF TO TERMINATE PROGRAM

SIGN OFF
OK, LO

ANMS (7) LOGGED OUT AT 19:47 033082
 TIME USED 0:17 0:31 0:24
 OK,

**Chart Corrections
 Subsystem
 QS37
 (From Telex Query)**

**Underlined entries are
 typed in by users.
 Refer to text for instructions.**

Figure 2

COMSAT USA 06019 03/30 2025Z#
1503167 CGTS

GA
00230908140+

03/30/82 2026Z HLOGIN PLEASE
ERS LOGIN ANMS

PRIMOS VERSION 18.2
ANMS (7) LOGGED IN AT 20:29 0033082

PLEASE ENTER YOUR USER IDENTIFICATION
XXX

WELCOME TO THE AUTOMATED NOTICE TO MARINERS SYSTEM

OK, R ANMS

ENTER JOB TO RUN OR MENU TO DISPLAY PROGRAM MENU

QS37

SUMMARY EXTRACT OF CHART CORRECTIONS
PLEASE SELECT ONE OF THE FOLLOWING OPTIONS:

1. ALL CORRECTIONS TO SELECTED CHARTS
2. CORRECTIONS FROM CURRENT NOTICE BACK TO A SELECTED NOTICE

PLEASE ENTER YOUR SELECTION (1 OR 2)

1
ENTER CHART NUMBER
12323

ENTER: NEXT CHART NUMBER
OR CARRIAGE RETURN TO START PROCESSING

		AUTOMATED NOTICE TO MARINER	3/30/82
		CHART CORRECTION QUERY SYSTEM	
		EXTRACT ALL CORRECTIONS TO SELECTED CHARTS	QS-37
12323	19ED.11/15/80	NEW EDITION	4/81 (NOS= 51/80 CG3)
	DELETE	BUOY +LE+	
		39DEG 28.2MIN N 74DEG 15.9 MIN W	
12323	19ED.11/15/80	LAST NM	4/81 1/82 (47/81 CG3)
	RELOCATE	BUOY (39DEG 44MIN 45SEC N 74DEG 34MIN 51SEC W) TO	
		39DEG 44MIN 14SEC N 74DEG 35MIN 18SEC W	
	ADD	DANGEROUS WRECK (PA)	
		39DEG 44.2MIN N 74DEG 08.4 MIN W	
12323	19ED.11/15/80	LAST NM	1/82 7/82 (1(43)81 OTTAWA)
	DELETE	ALL REFERENCE TO LORAN-A RATES	
		NOTE: STATIONS PERMANENTLY DISCONTINUED	

EOJ-QS37

ENTER JOB TO RUN= MENU TO RE-DISPLAY MENU
OR SIGN OFF TO TERMINATE PROGRAM

SIGN OFF
OK, LO

ANMS (7) LOGGED OUT AT 20:47 033082
TIME USED 0:18 0:31 0:22
OK,
03/30/82 2045Z 018.7 MIN

**Chart Corrections
Subsystem
QS37
(From Satellite Telex Query)**

**Underlined entries are
typed in by users.
Refer to text for instructions.**

AUTOMATED NOTICE TO MARINERS (ANMS) FLOW CHART

