

# THE ELECTRONIC CHART

A REPORT BASED ON A WORKSHOP  
HELD AT THE  
UNIVERSITY OF NEW BRUNSWICK  
21-23 JUNE 1982

ANGUS C. HAMILTON  
BRADFORD G. NICKERSON

July 1982



TECHNICAL REPORT  
NO. 102

## PREFACE

In order to make our extensive series of technical reports more readily available, we have scanned the old master copies and produced electronic versions in Portable Document Format. The quality of the images varies depending on the quality of the originals. The images have not been converted to searchable text.

## FOREWORD AND ACKNOWLEDGEMENTS

This report is the result of the first "Workshop on the Electronic Chart". The workshop, held at the University of New Brunswick, Fredericton, from 21 to 23 June 1982, brought together mariners (users), hydrographers (chart producers), marine regulation administrators, and researchers in relevant fields (see 'Participants').

Although each participant spoke briefly on his area of expertise, much of the time was spent in semi-structured discussion. Sessions were designated for discussion of:

Rationale: Why? When?

The long term goal (assuming no constraints).

Technology review and critique: Hardware/software potential and limitations (constraints).

Non-technical constraints: Legal, regulatory, administrative, and financial constraints were all considered.

The short term objective.

A development scenario.

The aim of the workshop was to explore the implications of electronic technology advances on the production and use of the nautical chart. In this report, the authors have tried to incorporate the consensus from the presentations and discussions at the workshop. Much of the detail presented in the technology review session has been included in the appendices, along with additional material provided subsequently by the participants.

In mid-July a draft of this report was distributed to all participants for review. On receipt of the reviews, considerable re-structuring of the report was done, but no significant changes were made in the executive summary or in the conclusions. Having followed this procedure, the authors are confident that the significant statements and conclusions presented here are a valid consensus of the discussions.

The Electronic Chart Workshop and preparation of this report were sponsored by the Canadian Hydrographic Service, Department of Fisheries and Oceans, Ottawa, through DSS contract serial number OSC82-00127. Mr. R.M. Eaton was project officer for this contract and, in collaboration with Mr. N.M. Anderson, did the pre-workshop planning.

The authors gratefully acknowledge the expertise of Ms Wendy Wells in editing the text and in compiling it on the word processor.

## PARTICIPANTS

### Canadian Hydrographic Service

Mr. Neil Anderson. Director, Planning and Development, Ottawa  
Mr. Tim Evangelatos. Acting Director, Marine Cartography, Ottawa  
Mr. George Yeaton. Chief, Nautical Geodesy, Ottawa  
Mr. Patrick Hally. Head, Hydrographic Development, Quebec Region  
Mr. Tony Mortimer. Hydrographer, Pacific Region  
Mr. George MacDonald. Head, Hydrographic Development Section, Central Region  
Mr. Mike Eaton. Head, Navigation Group, Atlantic Region

### Canadian Coast Guard

Mr. William Vasiliou. Marine Casualty Investigation Division, Ottawa  
Mr. Rick Bryant. Regional Manager, Aids and Waterways, Vancouver

### Department of Energy Mines and Resources

Mr. Roger Defoe. Chief, Aeronautical Charts Division, Surveys and Mapping Branch, Ottawa

### Department of National Defence

LCmdr. Earl Dawson. Directorate of Cartography, National Defence Headquarters, Ottawa

### Newfoundland School of Fisheries, Navigation, Marine Engineering and Electronics

Capt. Doug Skinner. Instructor, St. John's

### Texas Instruments Incorporated

Dr. Gerry Burnham. Manager, Advanced Navigation Technology Branch, Lewisville, Texas

### Navigation Sciences Inc.

Mr. Mortimer Rogoff. Consultant, Washington, D.C.

### Department of Surveying Engineering University of New Brunswick

Dr. Salem Masry. Professor & researcher in digital mapping  
Dr. John McLaughlin. Professor & researcher in cadastral systems and legal aspects of mapping and charting  
Dr. David Wells. Professor & researcher in hydrography and marine geodesy  
Prof. Angus Hamilton. Chairman of the Department & researcher in land information systems  
Mr. Bradford Nickerson. Lecturer & researcher in geodesy and graphic display systems

## TABLE OF CONTENTS

	<u>Page</u>
FOREWORD AND ACKNOWLEDGEMENTS	i
PARTICIPANTS	iii
TABLE OF CONTENTS	iv
LIST OF FIGURES	v
LIST OF TABLES	vi
GLOSSARY OF TERMS	vii
EXECUTIVE SUMMARY	1
1. Definition of 'Electronic Chart'.	4
2. Rationale.	5
3. Development Scenarios.	10
3.1 Arctic Navigation	11
3.2 Harbour Navigation	13
4. Summary and Conclusions	14
REFERENCES	16
APPENDIX 1: CHS Chart Production	18
A1.1 Interchange format	18
A1.2 GOMADS format	23
A1.3 Comments on the database requirements for the electronic chart	25
APPENDIX 2: Radar	27
A2.1 Radar processing	29
APPENDIX 3: Display Technology	34
A3.1 CRT fundamentals	35
A3.2 Flat panel displays	38
A3.3 Display of graphics	40
APPENDIX 4: IFR Electronic Charts	42
A4.1 IFR analogy	42

## LIST OF FIGURES

	<u>Page</u>
1. Computer Memory Density and Cost.	8
2. Integrated Navigation Information System.	10
3. Arctic Navigation Route.	12
4. Canadian Hydrographic Service Automated Cartography System.	19
5. Interchange File Format.	23
6. Freeman Vectors.	23
7. GOMADS File Structure.	24
8. Marine Radar Block Diagram.	27
9. DSC Block Diagram.	30
10. Functional Diagram of a DSC.	30
11. Pulse-to-Pulse Integrator.	31
12. Write-Address-Generation.	32
13. DSC Memory Organization.	33
14. Electronic Display Market.	34
15. Basic CRT Construction.	35
16. Geometry of the Interlaced Scanning Pattern.	36
17. Scanning Technique.	37
18. Horizontal Scan Resolution.	37
19. Plasma Panel Schematic.	39
20. Plotting Graphic Data.	40
21. Aircraft Electronic IFR Chart Generation.	42
22. Sample Cockpit Displays of Navigaton Database Information.	45

## LIST OF TABLES

	<u>Page</u>
1. Atlantic Canada Fishing Fleet.	7
2. The Content of the Header for Each Interchange Format File.	20
3. The Content of the Descriptor.	21
4. The Coding for the Content of a Data String.	22
5. Technical Data of Radar Equipment.	28
6. Sections and Sub-Sections of IFR Navigation Database.	43
7. Airport Reference Point Record Definition.	44



## GLOSSARY OF TERMS

AES	Atmospheric and Environment Service.
ARINC	Aeronautical Radio Incorporated, a publisher of aeronautical literature.
ARPA	Automatic Radar Plotting Aid. A computer analyses the "blips" on a radar screen: for example, if a blip is moving it computes the direction and speed of motion.
ATC	Air Traffic Control.
BIONAV	Bedford Institute of Oceanography Integrated Navigation System.
Bit	One binary digit (1 or 0).
BRM	Binary-rate multipliers.
Byte	Eight bits—1 alphanumeric character expressed in binary notation.
CCG	Canadian Coast Guard.
CHS	Canadian Hydrographic Service.
CRT	Cathode Ray Tube (similar to a TV tube).
DAD	Descriptor And Data string.
DSC	Digital Scan Converter.
GOMADS	Graphic On-line Manipulation And Display System. That part of the CHS automated cartography system in which the interactive editing and compilation is done.
GPS	Global Positioning System. A network of satellites planned by the United States military to serve as navigation aids anywhere in the world at any hour of the day.
IFR	Instrument Flight Rules (for aircraft).
IMCO	Inter-governmental Maritime Consultative Organization.
LCD	Liquid Crystal Display.
LORAN-C	Long Range Navigation. A hyperbolic long wave navigation aid maintained in North America by the Canadian and U.S. Coast Guards.
nmiles	Nautical miles.
NTX	Interchange. Designation for the file into which digitized data is collected and stored in the CHS automated cartography system.
PDI	Position Description Instructions.

PPI	Plan Position Indicator. A CRT display of radar echoes.
RADAR	Radio Aid for Direction And Ranging.
RAM	Random Access Memory.
RGB	Red, Green and Blue dot pattern of a colour CRT.
ROM	Read-Only Memory.
TCR	Tailored Company Route.

## ELECTRONIC CHART WORKSHOP

### EXECUTIVE SUMMARY

The workshop on the electronic chart brought together a group of individuals with different but relevant expertise pertaining to the development of the electronic chart. After three days of discussion, the group had a much better concept of the electronic chart and a better understanding of the potential and of the limitations of the relevant technology. To the best of our knowledge, the electronic nautical chart had never been discussed previously in any forum or at any formal meeting in Canada.

When all the expectations for navigation to meet modern shipping requirements are combined with the present and imminent state of the art in technological advances, it becomes clear that the evolution of the electronic chart is inevitable, and the only uncertainty is in the tempo of this evolution and of the specific ways in which it will evolve. There are at least six different forces contributing to the rationale for the evolution of the electronic chart.

1. There is a need for electronic charts to complement the navigational arsenal that will be needed for safe transportation of oil and gas from the arctic islands to the east coast. One reason that the arctic poses a special navigation challenge is that due to ice floes, conventional channel markers and buoys cannot be maintained. Similar conditions and a similar challenge will arise if, as has been proposed, the St. Lawrence seaway is kept open all winter. It needs no imagination to recognize that navigating in channels without markers and buoys can only be done safely by having additional navigational tools on every ship.
2. There is a technological push from developments such as LORAN-C, the Global Positioning System (GPS), the modern radars, and the Automatic Radar Plotting Aids (ARPAs) as well as new and upcoming improvements in display technology, all supported by low cost microprocessors.
3. There is a general transportation industry thrust. This is most apparent in flight management computers for Instrument Flight Rule (IFR) flying by the airlines. There is also the as-yet novel idea of an electronic road map in a dashboard display along with a GPS receiver in automobiles.

4. There is a Canadian Hydrographic Service (CHS) development momentum. This started some 15 to 20 years ago and is evident in developments such as the Bedford Institute of Oceanography Integrated Navigation System (BIONAV) and the now generally common digital data collection, not to mention digital chart production.
5. There is societal pressure for regulations aimed at reducing marine fatalities and pollution hazards; when it can be shown that the electronic chart will help in meeting this objective, we can be assured that there will be pressure for regulations to make it mandatory in tankers and larger vessels.
6. Finally, the most compelling evidence of the need for the electronic chart is the fact that other agencies are now digitizing existing nautical charts at their own expense.

When presented with this array of evidence, the workshop had no difficulty in reaching a consensus that the CHS should be moving cautiously but steadily in the development of the electronic chart. It was apparent that the digital data base now available as a by-product in the production of conventional CHS charts should be exploited for use as a "user" product in its own right.

As is often the case, it was not difficult to get a consensus on a long-term scenario. Specifically, the workshop agreed that some form of fully integrated position and navigation system will evolve. Some type of master monitor will be available for the officer on watch to have an overview that includes a display of all the relevant information from the electronic chart, from the radar or radars, as well as the position of the ship and any other inputs such as visual observations, etc. It is obvious that there is a problem not only in selecting and deciding what he should have on his monitor but also a problem in insuring that irrelevant, distracting material is not allowed to clutter the monitor.

When it came to the discussion of the short term scenario, there was agreement that we simply did not have the information at our disposal to resolve this question unequivocally. Rather it was agreed that the options should be stated as clearly as possible and left for further discussion. The options are: Should the path toward the master monitor be by enhancing and superimposing chart and position data on the radar data, or should position and selected radar data be superimposed on the electronic chart?

At this stage it appears that promising developments along both avenues should be explored, and those that withstand the tests of the real world will survive and the others will fall by the wayside.

## 1. DEFINITION OF 'ELECTRONIC CHART'.

There is as yet no widely accepted definition for the term 'Electronic Chart'. In fact, during the planning of the workshop, alternative titles, such as 'Video Chart', were considered. In other words, even though the concept is fairly clear, the terminology is not. The concept is that all of the data needed by a mariner on the bridge of a ship would be stored in computer memory and would be instantly available for display.

Language has its own way of evolving. Reference to a comparable evolution of the name for a new concept may be instructive. Radar, as everyone knows, originated as an acronym--Radio Aid for Detection And Ranging--which, through widespread usage, became a noun. Before the acronym, radar, appeared, several other labels, such as 'radio direction finding', usually abbreviated to r.d.f., were used.

As the main purpose of the workshop was to get a better understanding of the concept and to develop a consensus on what should be done, it would have been counter-productive to engage in a semantic debate on terminology prior to addressing the concept. Ultimately, a "natural" label for this concept will win acceptance. Whether or not it is 'electronic chart' is not important now. In the meantime, the Workshop participants accepted 'electronic chart' without debate.

## 2. RATIONALE

As noted in the Foreword, the aim in this report is to present a consensus of the discussions rather than to compile "proceedings". Nevertheless, it is appropriate to cite one statement verbatim. Mike Eaton, who did much of the planning for the workshop, has been thinking about the concept of the electronic chart for some time. His opening remarks, cited below, set the tone for the discussions that followed.

"I look on the electronic chart as an almost inevitable step in the development of the equipment on the bridge of a ship. It will free the officer of the watch from the "blind periods" when he cannot see what is going on because he has his head in the chart table plotting the ship's position; and it will relieve him of worrying about what dangers the ship may be running into when he cannot plot his position because he is talking on the radio to Traffic Control or carrying out a collision avoidance manoeuvre.

Putting together the hardware and the software for the electronic chart is a job for industry. The part the Canadian Hydrographic Service should play is firstly to provide as appropriate a data base as we can, and then to take responsibility for how that data base is used. Our paper charts display prominently the main hazards to navigation (shoals and danger line contours), and the primary aids (buoys, beacons, etc.), and they are never drawn on a larger scale than the survey, to avoid exaggerating survey errors; these and other essential features must somehow be retained in the electronic chart.

There are two ways of responding to this responsibility:

- (1) Wait until electronic charts are being produced commercially, and then adapt our data base as best we can, and fire-fight any bad practices that occur in the use of it.
- (2) Operate a pilot scheme ourselves, in collaboration with industry, so that we build up some experience in using the present hydrographic data base to produce an electronic chart, and in using the electronic chart at sea.

Obviously, the second option is preferable. We should not invest large sums of money in this, yet we need to make our electronic chart

close enough to the final version to get meaningful results from it; and we need to do it soon enough to have our conclusions ready by the time the commercial demand arises."

Although discussion of the rationale for proceeding with the development of the electronic chart following Mike's opening remarks was scheduled to be completed in the first session, questions and comments on rationale recurred frequently throughout all three days of the workshop. From these discussions the following signposts emerged as representing the more significant items of support for proceeding with the development of the electronic chart.

1. Transportation of oil and natural gas, discovered in the Beaufort Sea and the arctic islands, through the northwest passage to the east coast (see Figure 3) is expected in 1986. Because it is impossible to maintain buoys and channel markers in ice and because, at any reasonable cost, it is also impossible to maintain lights and radio navigation aids dependably in remote areas, real-time tracking will be essential. The problem is further aggravated by the fact that where there is no significant coastal relief, radar cannot discriminate between the ice edge and the shoreline. Under these conditions, the need for accurate, real-time tracking of the ship will generate pressure for the rapid development of electronic bridge displays of ice and environmental conditions, of true position, of radar input, and of chart information.

2. Provision of a navigational system database for flight management computers on aircraft using IFR procedures is being done today (1982). Detailed documentation of this database has been available since 1980 [ARINC, 1980]. Such a system would not be evolving in the cost-conscious air industry if it were not essential. For shipping the same basic problem--information overload--is creating excessive pressure for the officer on watch: more traffic, higher speeds, more dangerous cargoes, and more information coming from nav aids, from traffic control radio, and from other ships are creating overload conditions similar to those that have already occurred in the air.



3. Widespread acceptance of LORAN-C by the marine community and its integration with video displays of ship's track, waypoints, and overlaid grids [Furuno Electric Co. Ltd., 1981; JRC, 1981; Navigation Sciences Inc., 1981] provides continuous real-time positioning. As of 1981, more than 50% of vessels over 25 tons (about 40 feet) in areas of LORAN-C coverage on the east coast of Canada have LORAN-C receivers (see Table 1).

VESSEL CHARACTERISTICS				VESSEL EQUIPMENT (%)		
<u>Tonnage</u>	<u>Length (ft)</u>	<u>Value (K\$)</u>	<u>Total Fleet</u>	<u>Sounder</u>	<u>Radar</u>	<u>Loran (NS/NB only)</u>
0- 10	0- 30	1- 3	27000	2- 27	0- 3	1
10- 25	30- 40	3- 20	5000	74- 85	43- 60	22
25- 50	40- 50	20- 70	700	64-107	66-114	101
50-100	50- 70	70- 250	300	92-127	96-143	124
100-150	70-100	250	80	75-121	100-139	120
150+	100+	250-2000	<u>300</u>	99-140	100-162	157
			33500			

TABLE 1. Atlantic Canada Fishing Fleet (1979-1980 statistics [Wells, 1982]).

4. Worldwide, real-time navigation capability with GPS is scheduled for service in 1987. Any ship in the world with a GPS receiver will be able to determine its position within 500 m without worrying about lane slips or limited coverage.

5. Collection and processing of hydrographic field data in a digital form is becoming increasingly common. This provides an impetus to carry the digital format right through the chart production process.

6. Modern radars which can display true motion as well as waypoints and planned voyage information are now (1982) on the market (although rather expensive). Integration of radar and positioning equipment leads naturally to the requirement for nautical chart information in digital form for radar display.

7. The possibility of winter navigation through the St. Lawrence seaway and the Great Lakes will require some form of integrated positioning and electronic chart or radar system; such a system will be necessary because the presence of ice will make it impossible to keep buoys in position.

8. Computer memory is becoming increasingly cheaper and denser (see Figure 1). Considering that 256 KBit memory chips are now being fabricated [Electronics, 2 June 1982, p. 56], computer memory size and cost will have a favourable influence on the development of the electronic chart.

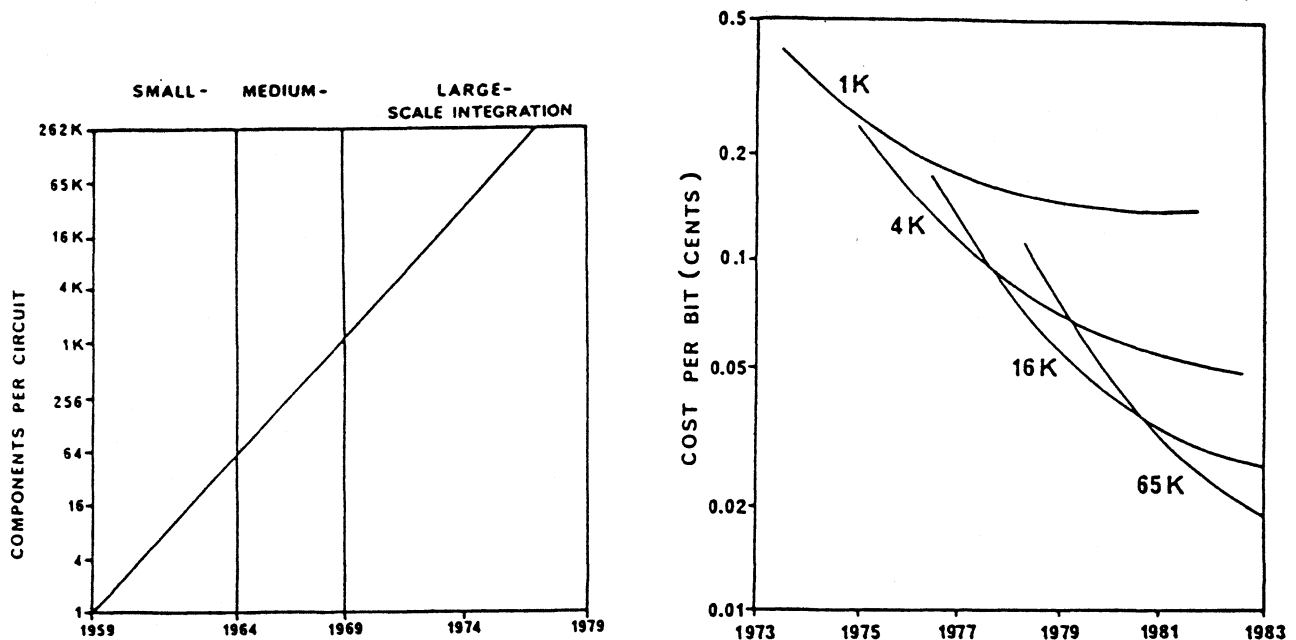

FIGURE 1. Computer memory density and cost (after Noyce [1977]).

9. Digital mapping technology for land-based maps is maturing and becoming widely available. Maps at 1:50 000 are being produced digitally now, and a program to digitize all of the 1:250 000 maps is in the advanced planning stage.

10. A North American automobile manufacturer is presently showing prototypes of a dashboard map display integrated with a Doppler satellite positioning receiver [Electronics, 2 June 1982, p.54].

11. Other organizations are already digitizing CHS charts for their own purposes [Mortimer, 1982]. Widespread digitizing of CHS charts by others creates inconsistent versions and confusion which can only have an adverse backlash on CHS.

12. Current regulations require several electronic navigation aids including radar—one radar for ships larger than 500 tons and two for ships larger than 1600 tons [Government of Canada, 1978]. Revisions to these regulations are a precursor to the requirement for electronic charts.

13. Display technology is progressing somewhat differently than computer memory technology. Standard radar Plan Position Indicator (PPI) displays usually are viewed with a hood during daylight. Standard raster television monitors are available in colour with 525 by 525 pixel resolution. These units are relatively large and susceptible to interference and maintenance problems due to the high voltage required for CRT displays. Availability of flat, tubeless, high resolution (1024 by 1024), relatively cheap displays will be a major breakthrough for electronic charts.

14. Manual plotting of position fixes on paper charts by the officer on watch aboard a ship occupies precious time when other things may be happening on the bridge. Automatic plotting of the ship's position overlaid on an electronic chart display would relieve the officer on watch of this time-consuming task, and free him or her for more immediate duties. ARPAs (see Appendix 2) now being developed will contribute to the solution of this problem.

All of the above signposts point to the inevitable fact that some form of electronic chart is just on the horizon. At first, it may not look like the paper nautical chart mariners are accustomed to seeing. By the year 1990 electronic technology will have advanced to the point where an electronic display of paper chart quality will be feasible for many applications.

### 3. DEVELOPMENT SCENARIOS

From the discussion in the session on technology, it was clear that electronic technology advances are paving the way for major changes in marine navigation. Availability of low-priced, single-chip microprocessors with 32 bit registers provides tremendous potential for computationally intensive tasks to be performed electronically. One such example is the plotting of marine charts on a video display using some form of electronic chart. Instead of being the medium on which it is printed (paper), the chart assumes its analytical form. The spatial relationships of coastline, hazards, shipping channels, navigational aids, and bathymetry are stored digitally on a medium readable only by computer. The capability to display any portion of the chart, to change its scale, to plot and erase waypoints, to plot and maintain a permanent record of course made good, to add or delete grid lines, and to implement without delay current notices to mariners makes the electronic chart a very useful entity.

Consideration of methods for development of a prototype electronic chart for the CHS must have both long-term and short-term development in mind. In the long term, it is inevitable that a relatively low cost integrated navigation information system will be developed commercially. An example of this is depicted in Figure 2. A system (without GPS) similar to that

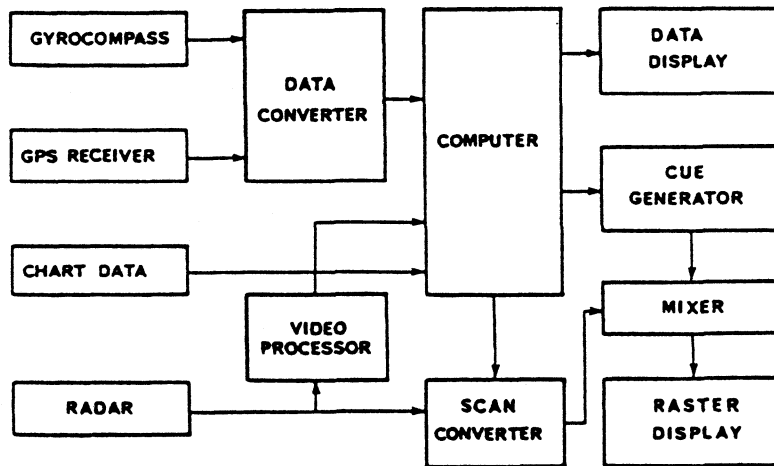

FIGURE 2. Integrated Navigation Information System (after Tiblin [1978]).

depicted in Figure 2 was built by Sperry and installed aboard the USS McCandless in 1973 [Tiblin, 1978]. The high cost of such a system at the

time prevented it from becoming widely used.

Availability of nautical chart data in digital form is an essential prerequisite for a system such as that shown in Figure 2. For channel and harbour navigation, the digital data may include a shoreline with buoys, channel depths, prominent shoals, lights and other navigational aids. This corresponds roughly to the IFR digital chart now available for the air industry (see Appendix 4). High traffic areas, such as Vancouver harbour, Georgia Strait, the Great Lakes, the St. Lawrence seaway, and Halifax harbour, would be the most logical place for such charts.

In the opinion of the users [Skinner, 1982; Dawson, 1982], the electronic chart must provide at least all the data presently on the paper chart. This implies that user pressure will require no deletion of information from the present format. In order to prevent cluttering of the display, it will be necessary to categorize data for display as required. Selective recall of spot soundings, navigation lattices, fishing zone boundaries, light information, bathymetric contours, topographic information, and shipping channels are some possible categories. Essential navigation information, such as shoals and channel buoys, should be "locked in" and always displayed on the chart.

The fundamental role of CHS in the future will be to provide the digital database for the chart information. Since digital data files have already been developed for in-house production of paper charts (see Appendix 1), the logical extension would be to provide these digital files to users on some electronic medium. As mentioned above, their long-term utility for the integrated navigation information system will depend on how easily the file structure will respond to selective queries.

In the short term, implementation of a prototype electronic chart system would be a valuable test of present CHS nautical chart digital data [Eaton, 1982]. Two development scenarios where the electronic chart would be useful are in hazardous navigation areas, such as the arctic, and high traffic areas at busy harbours. Both of these situations are considered to point out their differing requirements.

### 3.1 Arctic Navigation

Figure 3 shows the proposed route for transporting arctic oil and

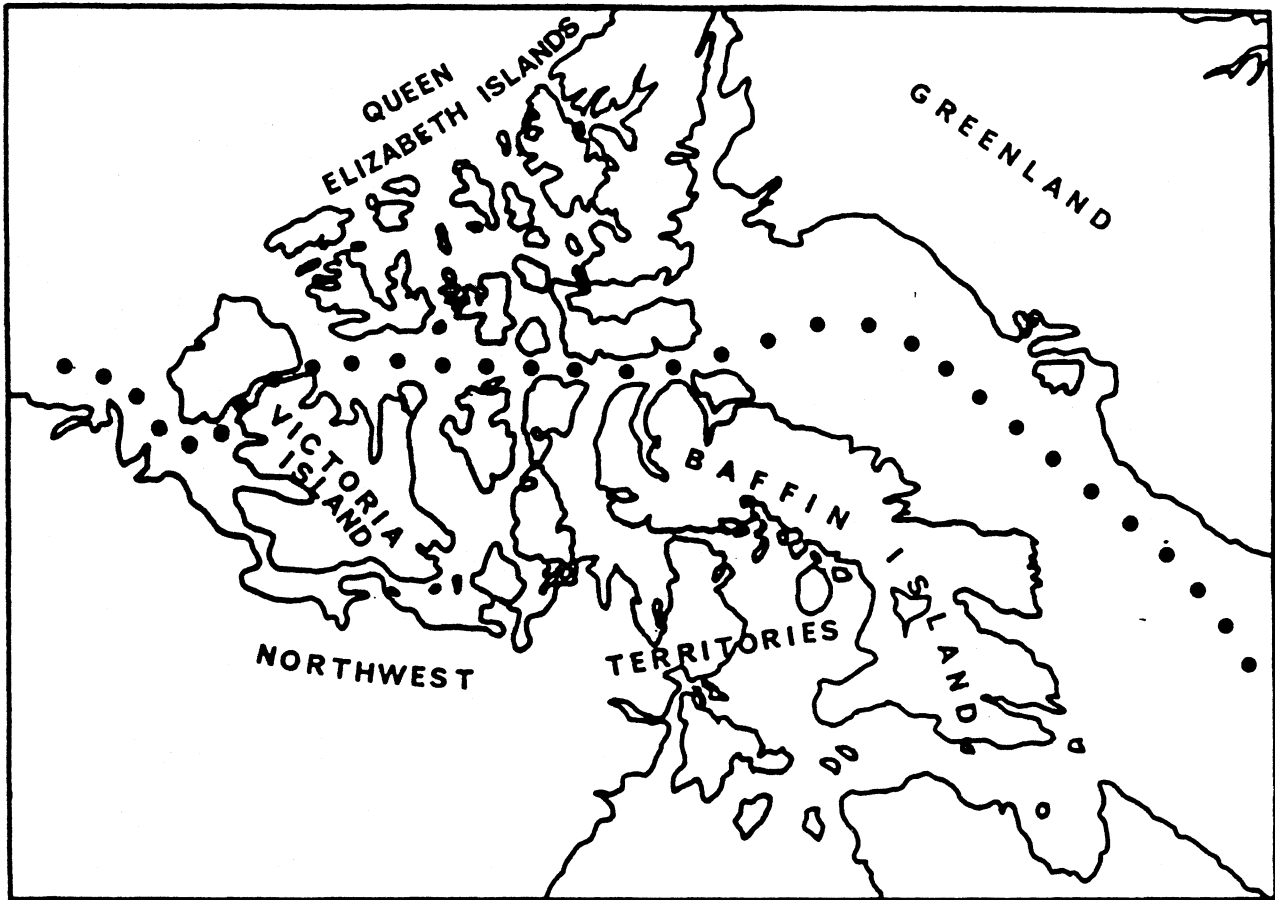

FIGURE 3. Arctic Navigation Route (after Mungall [1982]).

natural gas. Navigation through this arctic island route will be hazardous due to narrow channels, to lack of navigation aids, to year-round ice, and especially due to the fact that radar definition of a coastline with shore-fast ice is unreliable. A bridge display of the actual coastline, any shoals or pingoes, and selected soundings would be extremely valuable. In addition, the capability to overlay real-time transmitted ice charts from the Atmospheric and Environment Service (AES) fixed-wing ice reconnaissance flights would be very useful. These ice charts show different ice types and coverage using different codes. Interpretation of these codes is sometimes done by a colour scheme whereby older, thicker ice shows up as a more dangerous colour (e.g., red) [Nickerson, 1982].

For arctic electronic charts, the primary requirement is to be able to superimpose the charted coastline on the radar return. Other features which would be useful are the capabilities

- (1) to display ice conditions in colour;
- (2) to store and update ice maps in near real time;

(3) to incorporate new hydrographic survey data as it becomes available.

To accommodate all of these features, an integrated computer driven colour display console is necessary.

### 3.2 Harbour Navigation

This development scenario is somewhat analogous to the IFR electronic chart (see Appendix 4) of the air industry. Primary navigation aids, such as buoys, lights, prominent coastline features, shipping lanes, communication frequencies and depth contours, would all be necessary. The capability to integrate with radar and electronic positioning equipment, such as LORAN-C, is important. This gives a moving display of the radar returns superimposed on the electronic chart with the ship's position determined relative to the chart data.

Requirements for large scale digital chart data with the capability to selectively plot different features of it are the main requirements for harbour navigation. Any critical hazards, such as prominent shoals or primary navigation buoys, should be "locked in" to the display. The capability to automatically warn of imminent collision is a feature (similar to that on modern ARPAs (see Appendix 2)) which could be implemented on an electronic chart.

Many features of the arctic and harbour navigation development scenarios are common. Both need integration in some fashion with the radar and positioning system. Arctic navigation may have more of a real need for colour display of the chart. Harbour navigation needs a capability to keep track of moving targets and to display large scale charts accurately. The capability to operate with an interface to the depth-sounder and VHF radio could eventually lead to automatic pilots which determine position with respect to depth contours, and automatically steer the ship by means of a VHF radio link.

#### 4. SUMMARY AND CONCLUSIONS

1. The electronic chart is evolving and will evolve in diverse formats unless there is leadership and visible progress by the Canadian Hydrographic Service.

2. Some form of on-going forum for discussion of the electronic chart by mariners (users), by regulators, by hydrographers (producers), and by industry (navigation equipment) is needed.

3. The question of whether the display of the electronic chart will be merely one more "black box" on an already-congested bridge or whether it will be part of an integrated navigation system was resolved by concluding that mariners would eventually have to do as aviators are already doing—that is, develop an integrated navigation system with provision for warnings from any sensor detecting a possible hazard or a possible malfunction.

4. The fully integrated bridge system in which inputs on ship performance, fuel consumption, etc., are merged with navigation and safety information was raised and considered to be beyond the scope of this discussion on the electronic chart.

5. (a) The rate of development of ARPAs will have a significant bearing on the evolution of the electronic chart.

(b) It is generally agreed that only manually assisted ARPAs will have the confidence of mariners.



6. Recognizing that the electronic chart will evolve as an integral part of a fully integrated navigation system, three alternatives were identified:

- (a) A position centred system:  
selected electronic chart data and relevant interpreted radar data would be merged with position on one master monitor.
- (b) An electronic chart centred system.
  - (i) The position of the ship plus relevant interpreted radar data would be superimposed on the electronic chart in much the same way that various inputs are currently plotted on the paper chart.
  - (ii) Position plus relevant interpreted radar data along with selected electronic chart data would be presented on one master monitor.
- (c) A radar-centred system.
  - (i) Position plus selected electronic chart data would be superimposed on a radar screen.
  - (ii) Position plus selected electronic chart data would be presented along with interpreted radar data on one master monitor.

7. It should be noted that the differences between 6(a), 6(b)(ii), and 6(c)(ii) are more a matter of form than substance. There was a consensus in the workshop that such a system would evolve in the long term, however it was recognized that the question of the route, i.e., by 6 (a), by 6(b), or by 6(c), could not and should not be specified at this time.

8. Recognizing that the electronic chart is an integral part of all three alternatives outlined in (7) above, there was a consensus that CHS should proceed with one or more pilot projects as soon as possible.

## REFERENCES

- ARINC (1980). "Navigation system data base". Specification 424-1, Aeronautical Radio, Inc., Annapolis, Maryland.
- Bendix (1982). Advertisement for RDR 230 HP colour weather radar. Canadian Aviation, p.
- Bown, H.G., C.D. O'Brien, W. Sawchuk, J. Storey and R. March (1980). "Comparative terminal realizations with Alpha-Geometric coding". IEEE Spring Conference on Consumer Electronics, Chicago, Illinois.
- Burnham, G. (1982). "Electronic chart technology". Paper prepared for the Electronic Charts Workshop, University of New Brunswick, Fredericton, N.B., June.
- Burnham, G. (1982b). Personal Communication.
- Czartoryski, J. and C. Levy (1980). "Feature code manual". Canadian Hydrographic Service, Cartographic Research, Ottawa.
- Dawson, E. (1982). Presentation at the Electronic Charts Workshop, University of New Brunswick, Fredericton, N.B., June.
- Decca (1981).
- Eaton, R.M. (1982). Presentation at the Electronic Charts Workshop, University of New Brunswick, Fredericton, N.B., June.
- Evangelatos, T.V. (1982). Presentation at the Electronic Charts Workshop, University of New Brunswick, Fredericton, N.B., June.
- Fink, D.G. (1952). Television Engineering. 2nd ed., McGraw-Hill, New York.
- Fowler, K. and H.B. Lippert (1953). Television Fundamentals. McGraw-Hill, New York.
- Furuno Electric Co. Ltd. (1981). Advertising brochure for the Video Plotter, Model GD-102.
- Government of Canada (1978). Navigation appliance regulations. Canada Shipping Act, Queen's Printer, Ottawa.
- Hitachi America Ltd. (1981). Advertising brochure for Hitachi colour display monitors with in-line gun CRTs.
- Japan Radio Co. Ltd. (JRC) (1981). Advertising brochure for the JRC colour plotter, model NWU-50A.
- Mortimer, A. (1982). Presentation at the Electronic Charts Workshop, University of New Brunswick, Fredericton, N.B., June.

- Mungall, C. (1982). "Through the northwest passage." GEOS, Vol. 11, No. 2, pp. 1-5.
- Navais (1981). "Requirements for the carriage of navigational aids". Special Supplement to the International Convention for the Safety of Life at Sea (SOLAS 1974) protocol adopted by the IMCO Conference on Tanker Safety and Pollution Prevention (TSPP), 1978.
- Navigation Sciences Inc. (1981). "View-nav navigation system". Paper describing the View-nav system.
- Nickerson, B.G. (1982). "The SIAM system." Paper distributed at the Electronic Charts Workshop, University of New Brunswick, Fredericton, N.B.; June.
- Noyce, R. (1977). "Microelectronics." Scientific American, Vol. 237, No. 3, pp. 62-69.
- Oraas, S.R. and J.L. Kestner (1976). "GOMADS system overview". Unpublished paper, Canadian Hydrographic Service, Cartographic Research, Ottawa.
- Rogoff, M. (1982). Presentation at the Electronic Charts Workshop, University of New Brunswick, Fredericton, N.B., June.
- Skinner, D.G. (1982). Presentation at the Electronic Charts Workshop, University of New Brunswick, Fredericton, N.B., June.
- Sonnenberg, G.J. (1970). Radar and Electronic Navigation. 4th ed., van Nostrand Reinhold Company, New York.
- Suydam, S.E. (1982). "The world market for electronic displays". Electronics, May 5, p. 128.
- Tiblin, B.V. (1978). "Analysis of coastal navigation techniques".
- Wells, D.E. (1982). Presentation at the Electronic Charts Workshop, University of New Brunswick, Fredericton, N.B., June.

## APPENDICES

To fully understand the implications of, and problems inherent in, the electronic chart, the following review is made of the present CHS digital chart file structure, modern radar technology, general display technology, and the aircraft industry's approach to the electronic chart.

### Appendix 1

#### CHS Chart Production

Figure 4 gives an overview of the automated cartography system as it presently (1982) exists. The system is geared to produce film plots on a flatbed plotter as its end product. Each chart exists as its own file in so-called interchange (NTX) format. If the chart is to be interactively edited and compiled, using the Graphical On-line Manipulation and Display System (GOMADS), it must be transformed into the GOMADS data file structure. Similarly, if it is to be plotted, a file in plot tape format must be generated. There are thus three possible formats for the digital chart data:

- (1) interchange format;
- (2) GOMADS format; and
- (3) plot tape format.

#### A1.1 Interchange format

NTX format is the primary format presently used for data exchange and long-term data storage [Evangelatos, 1982]. Both the plot tape format and NTX format are essentially sequential files (see Figure 5) of records. The combined Descriptor And Data record is called a DAD. Each DAD has a maximum length of 72 words (144 bytes) if it is a Freeman vector line (see Figure 6), or 270 words (540 bytes) if it is another data type. DADs can be linked together for data longer than 270 words. The detailed contents of the file header, descriptors, and data are contained in Tables 2, 3, and 4. Approximately 1 MByte is required to store one chart in interchange format [Evangelatos, 1982].



Words	Contents	Words	Contents
1	Record length in 16-bit words (usually 150).	21-22	Scaling latitude (or central latitude).
2	Data source code, 2 ASCII characters: AP - aerial photography CH - chart CI - compiled information HP - harbour and other plans IN - inset FS - field sheet GS - GEBCO source MO - mosaic RE - reports and other sources TE - tests TM - topographic maps	23-24	Second scaling latitude.
3- 6	Data source number, 8 ASCII characters - field sheet number, etc.	25-26	Major semi-axis of the spheroid (A) in centimetres. When left as zero, the Clarke 1866 spheroid is used.
7	Source part number, 2 ASCII characters - used if source document is divided into parts.	27-28	Minor semi-axis of the spheroid (B) in centimetres. When left as zero, the Clarke 1866 spheroid is used.
8- 9	Source section number, 4 ASCII characters - used to identify various areas, if desired.	29-30	Scale factor at the central meridian for UTM or TM projections. When left as zero, .9996 is used.
10-11	Digitization date, if applicable.	31-38	Covering rectangle for the entire chart. All coordinates are in units as defined by the increment size (see No. 55 below).
12-13	Survey date, if applicable.	39-54	Lat./long. corners of the same rectangle calculated by MOSAIC.
14	Sounding units, 2 ASCII characters FF - fathoms FT - feet MR - metres or meters and decimetres.	55	Increment size--one 16-bit integer giving size of grid cell in .0001 inch units (e.g., 20 means digitizer units are 0.002 inches).
15	Survey type, 2 ASCII characters LL - lead line RC - reconnaissance (controlled) RU - reconnaissance (uncontrolled) ST - standard TS - track soundings	56	Number of descriptors. Zero, if unknown.
16	Projection, 2 ASCII characters LC - Lambert Conformal ME - Mercator PO - polyconic PS - polar stereographic TU - transverse Mercator UM - universal transverse Mercator	57	Number of records. Zero, if unknown.
17-18	Scale, one 32-bit integer.	58	= 'RE' for registered by MOSAIC. = 'NR' for not registered. The first DAD must be a graticule record. = 'XY' for cannot be registered--there is no graticule record.
19-20	Central meridian.	59	Number of times the data has been converted.
		60-61	Date that this tape was last processed.
		62	Time of day of last processing.
		Notes:	(1) All dates are 2 integer words. The first word contains the year (e.g., 1975) and the second contains the Julian day (e.g., 174). (2) Time of day is one integer word, hours and minutes on a 24 hour clock, (e.g., 1427 is 2:47 p.m.). (3) All latitudes and longitudes are expressed as one 32-bit integer, in milliseconds (e.g., 53° 12' = 191520000). (4) All character information is stored in 8-bit ASCII where the most significant bit is always zero (e.g., A is stored as octal 101). Two characters are stored per word. (5) All integers are in 16-bit two's complement form.

TABLE 2. The Content of the Header for each Interchange Format File.  
There is, generally, one file for each digitized map or chart.

Words	Contents
1	String length--length of DAD including string length word and all end-of-string indicators. In words. For code 1, maximum is 72. For all other codes, maximum is 270.
2	Source number--integer word from 1 to 32767 labelling the source from which this DAD is derived. If all DADs in a file come from the same source (e.g., the same field sheet), all descriptors will have the same source number.
3- 7	Feature code--10 ASCII characters, refer to digitization manual for explanation of these.
8	Min X )
9	Min Y )
10	Max X )
11	Max Y )
12	<p>Flags--16 bits, each of which can be set to indicate various things. At present, the following bits are used:</p> <p>bit 0 - set means this DAD is graphically linked to the next one.</p> <p>bit 1 - set means this DAD is logically linked to the next one.</p> <p>bit 15 - set means this DAD has been symbolized and thus represents graphical data. If code type is 1-4, then line weight word must be filled in.</p>
13	Line weight and/or extra flags--if code type is 1-4, then bits 0-5 contain the line weight, in .001 inch units.
14-15	Reserved for use by GOMADS.
16	Code type of data string to follow.

Note: Logical end of file is indicated by a descriptor completely filled with the number 100,000 octal.

TABLE 3. The Content of the Descriptor.  
 There is one descriptor for each short (up to 270) string of digitized data points. Each descriptor is used in the GOMADS sub-file as well as in the interchange file.

<p style="text-align: center;"><u>Code 1 - Freeman Vector Lines (see Figure 5)</u></p> <p>Word 1 - X ) Start coordinates of line, with reference to grid defined in 2 - Y ) main header.</p> <p>3 - X ) End coordinates of line. 4 - Y )</p> <p>5 - first vector word (contains 5 vectors). 6 - second vector word. . . n - 3 - last complete vector word. n - 2 - final vector word (contains up to 4 vectors). n - 1 - 100,000 octal ) end code n - 100,000 octal )</p> <p>NOTE: First vector word to the last complete vector word are in the following format:</p> <p>bit 15 - 0 12-14 - first vector 9-11 - second vector 6-8 - third vector 3-5 - fourth vector 0-2 - fifth vector</p> <p>The final vector word is as follows:</p> <p>bit 15 - 1 12-14 - number of vectors in this word (0-4) 8-11 - first vector (if necessary) 6-8 - second vector (if necessary) 3-5 - third vector (if necessary) 0-2 - fourth vector (if necessary)</p> <p style="text-align: center;"><u>Code 3 - Point to Point Lines.</u></p> <p>Word 1 - X ) First coordinate of line 2 - Y )</p> <p>3 - X ) Second coordinate of line 4 - Y )</p> <p>. . n - 3 - X ) last coordinate of line n - 2 - Y )</p> <p>n - 1 - 100,000 octal n - 100,000 octal</p>	<p style="text-align: center;"><u>Code 4 - Dashed Lines.</u></p> <p>Same format as Code 3 lines, but there must be an even number of points.</p> <p style="text-align: center;"><u>Code 5 - ASCII Text.</u></p> <p>Consists of a variable length text string (in 7 bit ASCII with the eighth bit zero) terminated by a null word, followed by another string, and so on until two null words in a row appear. Two words each containing 100,000 octal follow. The variable length text string must contain an even number of characters. If odd, a zero byte must be added.</p> <p style="text-align: center;"><u>Code 6 - Position with Text.</u></p> <p>Consists of 2 words containing an XY coordinate, followed by a variable length text string terminated by a null word, followed by another coordinate and text string, and so on until two words containing 100,000 octal are found in the position which should be occupied by the next coordinate.</p> <p style="text-align: center;"><u>Code 7 - Names.</u></p> <p>Names, each character has its own position and rotation angle.</p> <p>Word 1 - height of characters. ) 2 - slope of characters, degrees ) repeating group, 3 - line weight (units of 0.001 inches) ) one for each 4 - font of character ) character 5 - X ) in a 6 - Y ) name 7 - character, 7 bit ASCII ) 8 - rotation angle, degrees counter-clockwise. )</p> <p style="text-align: center;"><u>Code 8 - Position with Symbol.</u></p> <p>Repeating groups, each consisting of</p> <p>Word 1 - X 2 - Y 3-6 - label.</p> <p>The label words can be interpreted two ways. If bit 15 of the first word of the label is a zero, then the label consists of an eight character feature code extension. In this case, only the first two characters of the feature code in the descriptor are used, and the characters in the label are added to them. If bit 15 of the first word of the label is a one, then the label consists of the graphical information required to flash a symbol. In this case, we have</p> <p>Word 1 - X 2 - Y 3 - bit 15 set 4 - bit 0-14 - symbol disc number 5 - magnification 6 - symbol number 7 - rotation angle.</p> <p>The groups are repeated until two words each containing 100,000 octal are found in the next coordinate position.</p>	<p style="text-align: center;"><u>Code 10 - Soundings.</u></p> <p>Repeating groups, each consisting of</p> <p>Word 1 - X ) Coordinate of optical centre of sounding. 2 - Y )</p> <p>3 - depth, binary integer in feet or decimetres. If negative, sounding is underlined. 4 - flag word.</p> <p>The flag word has the following bits in use:</p> <p>bit 0 - sounding deleted due to overplot 1 - sounding selected 2 - sloped sounding 3 - manually digitized sounding 4 - contour label 5 - this sounding has been converted from one set of units to another 6 - deep soundings (metres or fathoms) 8-11 - reliability and saliency 12 - swept depth 13 - no bottom found 14 - bracketted sounding. The XY for this sounding is not the position of the depth, but is the position where the depth is plotted. 15 - reserved.</p> <p>The groups are repeated until two words each containing 100,000 octal are found in the next coordinate position.</p> <p>NOTE: Code 6 is used by the digitizing program for storing the graticule intersections that are used by the MOSAIC program to register the newly digitized graphic.</p>
-------------------------------------------------------------------------------------------------------------------------------------------------------------------------------------------------------------------------------------------------------------------------------------------------------------------------------------------------------------------------------------------------------------------------------------------------------------------------------------------------------------------------------------------------------------------------------------------------------------------------------------------------------------------------------------------------------------------------------------------------------------------------------------------------------------------------------------------------------------------------------------------------------------------------------------------------------------------------------------------------------------------------------------------------------------------------------------------------------------------------------------------------------------------------------------------------------------------------------------------------------------------------------------------------------------------------------------------------	--------------------------------------------------------------------------------------------------------------------------------------------------------------------------------------------------------------------------------------------------------------------------------------------------------------------------------------------------------------------------------------------------------------------------------------------------------------------------------------------------------------------------------------------------------------------------------------------------------------------------------------------------------------------------------------------------------------------------------------------------------------------------------------------------------------------------------------------------------------------------------------------------------------------------------------------------------------------------------------------------------------------------------------------------------------------------------------------------------------------------------------------------------------------------------------------------------------------------------------------------------------------------------------------------------------------------------------------------------------------------------------------------------------------------------------------------------------------------------------------------------------------------------------------------------------------------------------------------------------------------------------------------------------------------------------------------------------------------------------------------------------------------------------------------------------------------------------------------------------------------------------------------------------------------------------------------------------------------------------------------------------------------------------------------------------------------------------------------------------------------------------------------------------------------------------------------------------------------------------------------------------------------------------------------------------------------------------------------------------------------	------------------------------------------------------------------------------------------------------------------------------------------------------------------------------------------------------------------------------------------------------------------------------------------------------------------------------------------------------------------------------------------------------------------------------------------------------------------------------------------------------------------------------------------------------------------------------------------------------------------------------------------------------------------------------------------------------------------------------------------------------------------------------------------------------------------------------------------------------------------------------------------------------------------------------------------------------------------------------------------------------------------------------------------------------------------------------------------------------------------------------------------------------------------------------------------------

TABLE 4. The Coding for the Content of a Data String.

A data string may consist of any one of eight types of data. The format and content of a data string in the GOMADS sub-file is the same as it is in the interchange file.



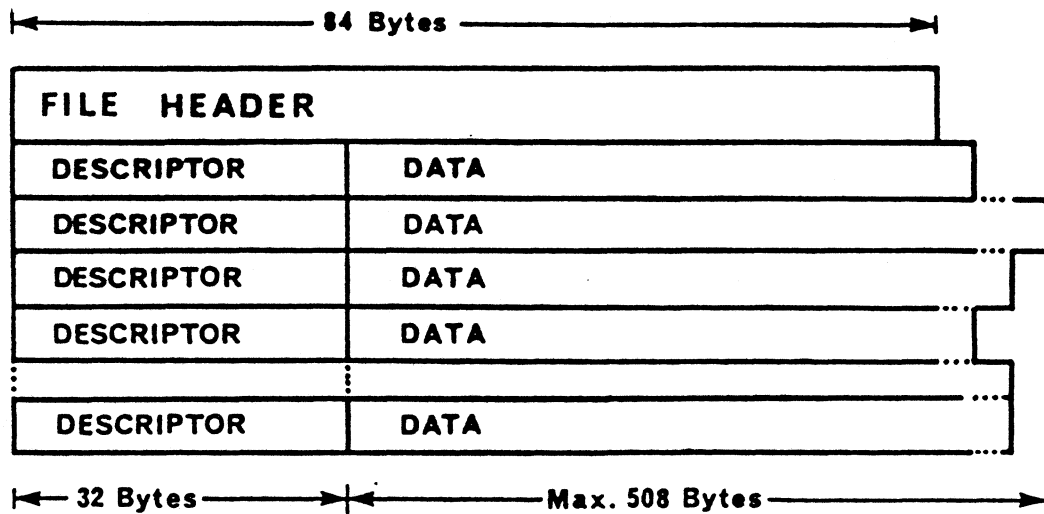

FIGURE 5. Interchange File Format. This is the format of the data when it is first digitized. There is one file header for each map sheet, and there is a DAD (Descriptor And its Data string) for each segment of data. A segment is up to 270 words in length.

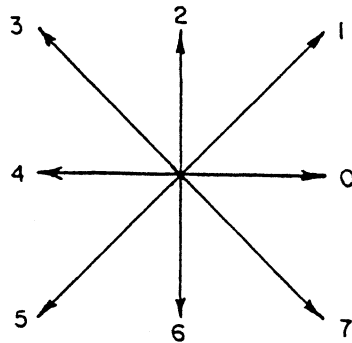

FIGURE 6. Freeman Vectors. The direction of a very short segment of a line is approximated by one of seven directions, called Freeman vectors. By representing each of these directions by a number from 0 to 7, five vectors can be put in one 16 bit word. This is much more compact than storing two x-y coordinates for each segment.

#### A1.2 GOMADS Format

The GOMADS file structure is designed for interactive editing of a chart file. It adds approximately 256 KBytes to the storage requirements for a single chart. Utility program GMDBLD is used to convert interchange format into GOMADS format. A gridded cell pattern, as shown in Figure 7, is superimposed on the chart. The 64" by 64" grid of 1/2" squares produces

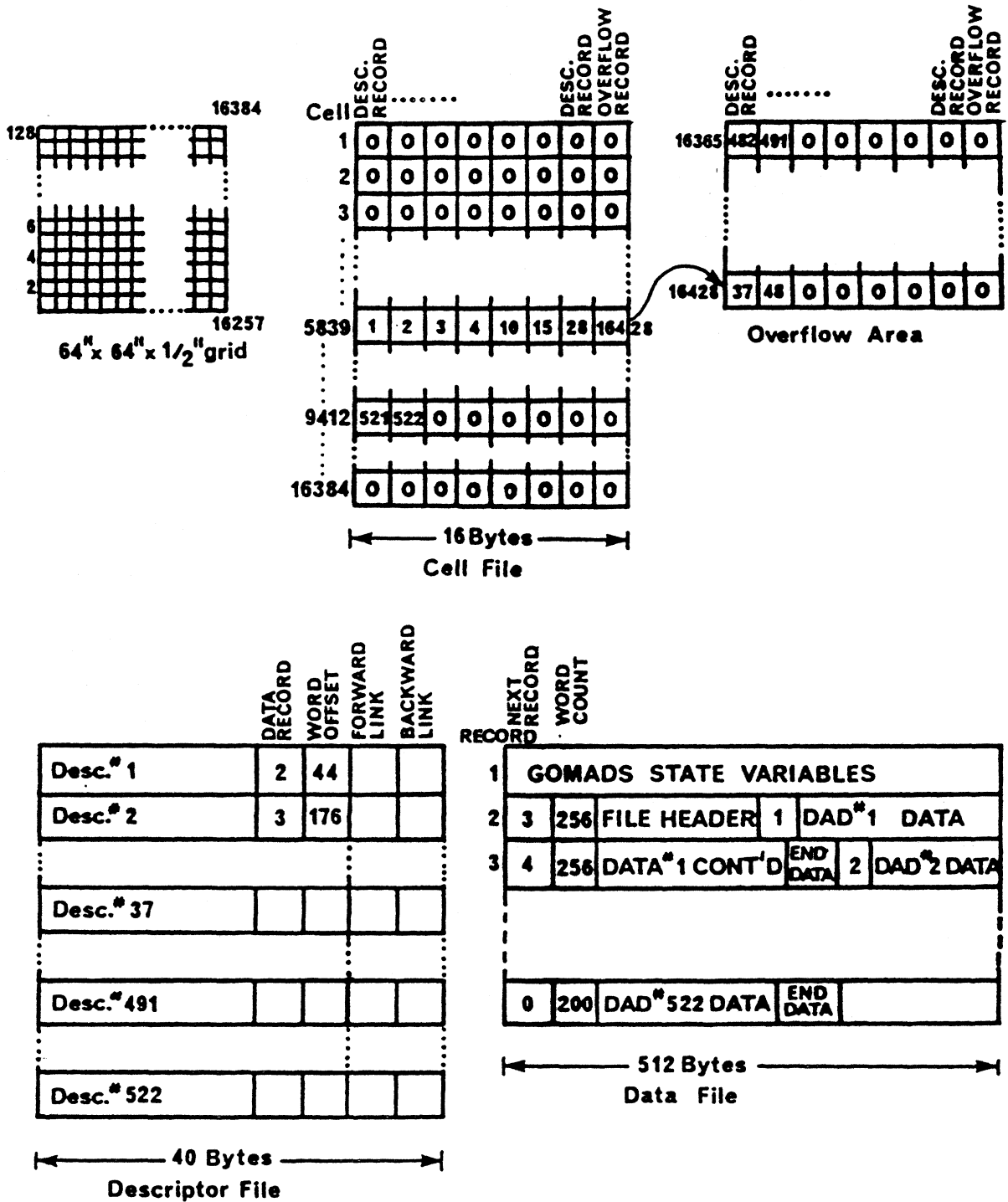

FIGURE 7. The GOMADS (Graphical On-line Manipulation And Display System) File Structure. There are three sub-files in GOMADS. The cell sub-file, the descriptor sub-file (see Table 3) and the data sub-file (see Table 4). The cell sub-file serves as an index to the other two sub-files.

16 384 source cells, each of which has its own 8-word record in the cell file. Each word of the cell record contains the number of a descriptor whose data intersects this cell. Since more than 8 descriptors may intersect it, an overflow area for cell intersections is provided.

The descriptor file contains the descriptors as in the interchange format but with four extra words appended to it. The first word gives the record number of this descriptor's data in the data file, and the second word is the offset (in 16 bit words) within the record where the data actually begins. If this descriptor is linked to another (e.g., part of a continuous shoreline), the last two words give the forward and backward descriptor numbers to which this descriptor is linked.

The data file contains all of the actual data from the interchange format files. In addition, the first record contains critical variables and I/O buffers which must be available when recovering from a system crash or power failure. These are rewritten every time a GOMADS command is executed. The data records are contained in 512 byte records, and can start or end anywhere within it. By knowing the next record (for this descriptor's data), and the number of words occupied in the record, each descriptor's data can be found within the data file.

The GOMADS file structure is composed of three sub-files. The gridded cell structure facilitates rapid search and recovery of data when editing a chart. Transforming the cursor position of the Tektronix 4014 into "source coordinates" enables immediate identification of the cell where the required data is located. All data intersecting this cell is recorded by its descriptor in the individual cell file records, and looking through this data is much faster than searching through the whole chart's data. The rapid adding, deleting, and moving of lines, symbols, names, and other chart entities is also facilitated by this structure.

#### A1.3 Comments on the database requirements for the electronic chart.

Interactive editing of the chart is not a requirement for shipboard use. The digital chart will be displayed at various scales, with additional waypoints and track plots superimposed on it. The primary demand will be to display within a specified window only certain types of data at a time, to erase those and plot others, or to point at a feature (e.g., a lighthouse), and find out specific information about it (e.g., flashing sequence and

foghorn patterns). Chart information does not regularly need to be deleted, moved, or added to (real-time implementation of notices to mariners is the exception). Some facility to "lock in" essential chart features, such as shoals and channel markers, so that they are always displayed should be considered.

The type of data within a specific record is identified by its feature code (see Table 2). There are presently 500 possible feature codes [Czartoryski and Levy, 1980] (e.g., 29 different symbols for 29 different "bottom qualities"). Requirements for displaying these features on an electronic chart will probably be different from their display on the paper chart. Queries such as finding all contours less than six fathoms or finding all bottom quality symbols within a specified area are examples.

Searching for data within a moving window (i.e., the shipboard display of the chart area of interest) will be faster if the data is maintained in some sort of gridded cell fashion as for the GOMADS file structure. Identification of the cells viewable in the window will be relatively simple knowing the ship's location and scale of the display. Searching only these cells will be much faster than searching all of the cells in a chart file.

Another requirement for shipboard use will be relating chart coordinates to latitude and longitude values in real time. Plotting of reference grid lines, calculating distance to chart symbols (e.g., headlands, shoals, buoys), and plotting of waypoints and ship's track on the electronic display are some examples of the need for this capability. Since the digitized data is stored in "source coordinates" (usually digitizer increments; see Table 3), this may not always be a trivial problem.

Crossing chart boundaries may not be a smooth transition, but since most charts are produced with some overlap, this may not be a problem. Presently inserts are shown to one side of a chart at a larger scale than the main chart. These should be identified as separate files so that a mariner can navigate on them individually.

## Appendix 2

### Radar

Most marine vessels rely primarily on radar for safe navigation. The electronic chart must be interfaced to it in some direct way to be of the most value (either the chart displayed on the radar, or the radar displayed on the chart) [Rogoff, 1982]. To understand the problems involved in doing this, a quick review of radar is worthwhile.

Figure 8 is a block diagram of a marine radar system. A pulse of

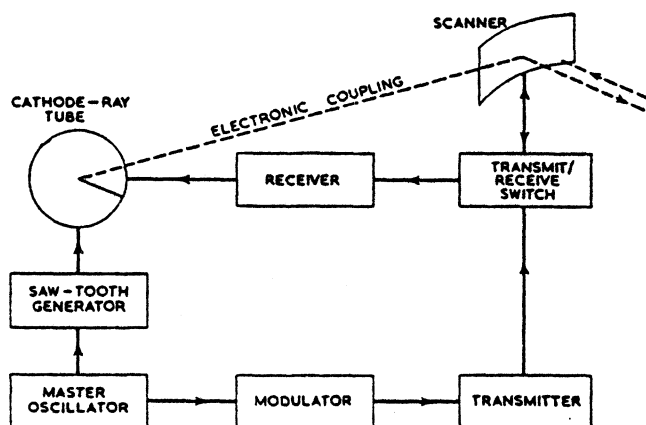

FIGURE 8. Marine Radar Block Diagram (from Sonnenberg [1970]).

microwaves (usually 3 cm wavelength) lasting from 0.05 to 0.5 microseconds is emitted at a repetitive rate of between 500 and 4000 pulses per second (depending on the manufacturer). This high energy pulse (e.g., 30 kW peak power or more) is transmitted from a directional antenna, which also receives any waves reflected back to it by nearby objects. Since the microwaves travel at the speed of light, the time after transmission that an "echo" is heard corresponds to the distance the target is from the antenna. For example, when a pulse is transmitted and an echo obtained back again in 99 microseconds (in a vacuum, the pulse will travel at 299 792 458 metres per second), the distance travelled is

$$d = 99 \times 10^{-6} \text{ sec} \times 299\,792\,458 \text{ ms}^{-1}$$

$$d = 29.68 \text{ km} = 16 \text{ nmiles,}$$

which means that the reflecting object is 8 nmiles away. Most radars presently display the echoes or returns directly on a cathode ray tube (CRT) (see Appendix 3) display, called a PPI. By supplying a sawtooth current to the deflection coils, the electron beam is deflected from the centre of the CRT to the outside edge. The time it takes the beam to go from the centre to the outside edge corresponds to the selected range (usually 1/2, 1 1/2, 3, 6, 12, or 24 nmiles). Any radar return is converted into a voltage which when applied to the CRT anode increases the electron beam intensity and results in a bright spot being displayed on the phosphor screen. By rotating the antenna and deflection coils through 360° at a rate of 15 to 25 rpm, the direction of the target can also be determined relative to the ship. Table 5 lists features of various marine radars.

Make and Type	Wave-length in cm.	Pulse duration in sec.		Pulse Recurrence Frequency, pulses/sec.		Horizontal beam width	Vertical beam width	Bearing discrimination	Range discrimination on ranges with short pulse length in yds	Bearing accuracy degrees	Range accuracy in percentage of range scale in use or in yards whichever is greater	Number of revolutions per min of scanner	Diameter screen inches	Ranges in nautical miles
		Short range	Long range	Short range	Long range									
Decca TM 629	3	0.05	1.2	2000	500	0.8°	15°	1°	10	1°	1% or 50 yds	20	12	1/2, 1, 1 1/2, 3, 6, 12, 24, 48
Decca D 202	3	0.1	0.5	1000	1000	1.9°	27°	2°	30	1°	1 1/2% or 75 yds	24	with lens 7 1/2	1/2, 1 1/2, 3, 6, 12, 24
Marconi Raymarc 16	3	0.06	0.6	2000	1000	1°	23°	1°	20	1°	1 1/2%	24	16	1/2, 1 1/2, 3, 6, 12, 24, 48
Kelvin-Hughes 17/12	3	0.06	0.5	2200	1100	1.2°	25°	1.2°	15	1°	1%	24	12	1/2, 1, 1 1/2, 3, 6, 12, 24
Raytheon 1660	10	0.05	0.6	4000	1000	1.8°	22°	2°	22	1°	2 1/2%	27	16	1/2, 1 1/2, 3, 6, 12, 24, 48
Furuno (Japanese) FR-151-TR	3	0.1	0.6	800	800	1.8°	25°	—	27	—	2%	20	7 with lens	1/2, 1 1/2, 4, 12, 32
Atlas (German) 5000	3	0.08	2.0	2000	500	0.9°	21°	—	19	—	1 1/2%	17	12	1/2, 1 1/2, 3, 6, 12, 24, 60

TABLE 5. Technical Data of Radar Equipment (from Sonnenberg [1970]).

Some modern marine radar sets provide the capability to display discrete lines on the CRT which do not correspond directly to any radar return signal. Air Traffic Control (ATC) radar displays operate in this fashion, continually drawing lines representing flight paths on top of the radar returns. Modern aircraft weather radar systems convert the return signal into digital form and perform signal analysis on it before displaying it on a colour CRT. This type of system can be easily interfaced with electronic chart files, and commercial aviation products to do this are now being sold

[Bendix, 1982].

ARPAs are now being installed on some larger (greater than 10 000 tg) ships. Inter-Governmental Maritime Consultative Organization (IMCO) performance standards specify that an ARPA must be able to

- (1) operate on 20 targets simultaneously if it is equipped with an automatic acquisition feature;
- (2) show at least 8 minutes of past history of targets being tracked;
- (3) provide target course and speed data in true and relative vector format;
- (4) provide visual and/or audible warning of (i) the approach of a distinguishable target within a chosen range, (ii) predict closest approach within a chosen time, and (iii) loss of a tracked target;
- (5) present, alphanumerically, for any tracked target, (i) range and bearing, (ii) predicted closest approach with a chosen time, and (iii) true course and speed.

These are just some of the performance standards specified [Nav aids, 1981].

At least nine companies are now producing ARPAs (some with two-colour displays), and all have the above mentioned features. Some units have straight line plotting capabilities to represent voyage planning or shipping channels. ARPAs integrate positioning and collision avoidance on the radar screen at a cost of roughly \$50,000.00 and up.

#### A2.1 Radar Processing

This section is an edited version of material supplied by Dr. G. Burnham of Texas Instruments Inc.

Integration of the nautical chart with radar is most easily performed if both data sources are in digital format. Radar digitization and display is normally done by a Digital Scan Converter (DSC). The basic functions are depicted in Figure 9. Analog video output from the radar is processed and stored in a random access memory (RAM). At the same time, the RAM contents are read out at a 525 line, 60 Hz rate to form standard television composite video for display on a television monitor.

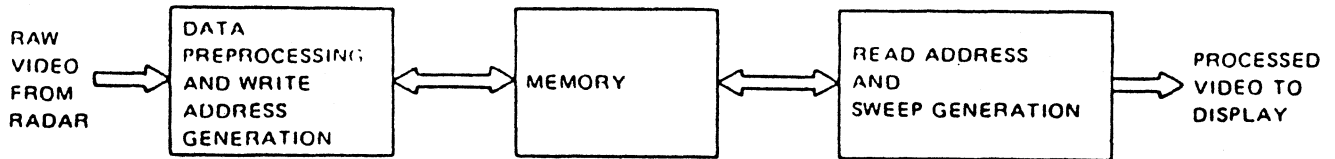

FIGURE 9. DSC Block Diagram (from Burnham [1982b]).

Figure 10 shows the identifiable functions contained within a DSC. Each

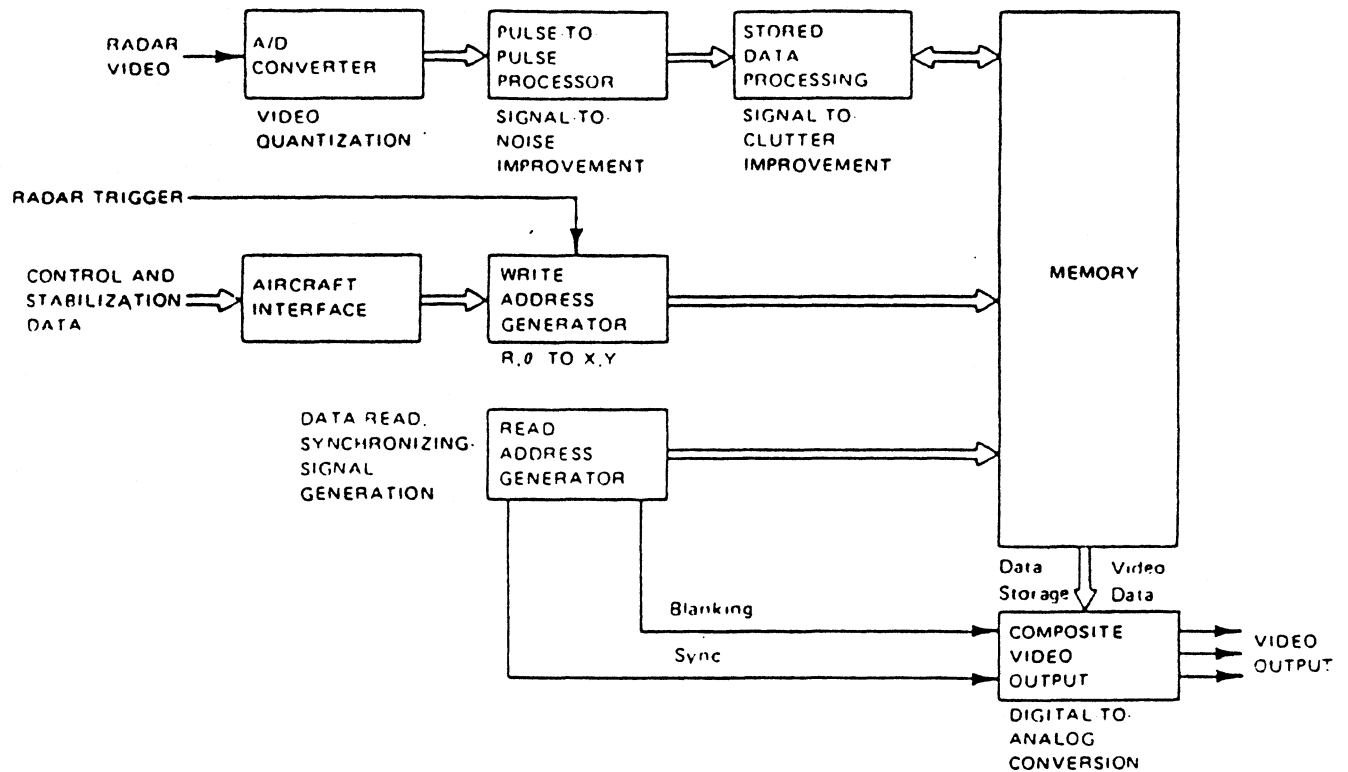

FIGURE 10. Functional Diagram of a DSC.

function is (usually) separately implemented on its own group of printed circuit boards as follows:

1. video quantization to convert the radar signal to a digital form;
2. pulse-to-pulse processing to improve the signal to noise ratio;
3. stored data processing to discriminate against sea clutter;
4. memory;



5. interfacing to obtain operator commands (such as radar range selection) plus ship's position, speed, and orientation;
6. write-address-generation to convert the input (R,  $\theta$ ) polar coordinates to (X,Y) memory cell coordinates;
7. read-address-generation to read data from memory synchronized with a television display raster;
8. generation of the composite video signal required for raster CRT display.

One important function of the DSC is to match the resolution of radar video to the raster display. Display resolution is determined primarily by the monitor bandwidth (see Appendix 3), whereas radar range resolution is determined by the radar pulsewidth. For example, a radar with a 20 nmile display and a 0.5 microsecond sample period would be capable of resolving 494 ( $\approx$  512) elements in one direction. "Stretching" the resolution by a ratio of 2:1 to give 256 elements enables the PPI display to be centred in a 512 by 512 memory. Stretching is accomplished by comparing the amplitude of adjacent cells and selecting the largest of the two for further processing and entry into the memory.

Pulse-to-pulse integration is mechanized with an array of shift registers operating in parallel as shown in Figure 11. Quantized video is

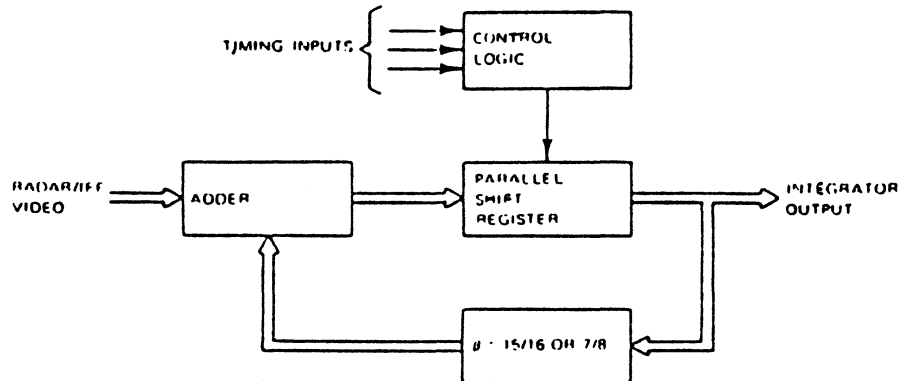

FIGURE 11. Pulse-to-Pulse Integrator.

added to a percentage of stored target information and stored in the shift registers. The stored information is derived from previous target returns which were previously stored in the shift register. A feedback factor defines the percentage of old information that is added to the new data. It is selected to produce an integrated time constant which matches the time

required to accumulate target returns from the number of radar pulses occurring in an antenna beamwidth.

For example, a radar with approximately 20 hits per two-way antenna beamwidth would use a feedback factor of 15/16. After 16 consecutive hits, the integrator would contain 63% of its maximum value. The signal to noise improvement caused by integrating 16 pulses would be at least 16 or 6 dB.

Write-address-generation is accomplished using the circuit depicted in Figure 12. The polar format of the radar data is converted into (X,Y)

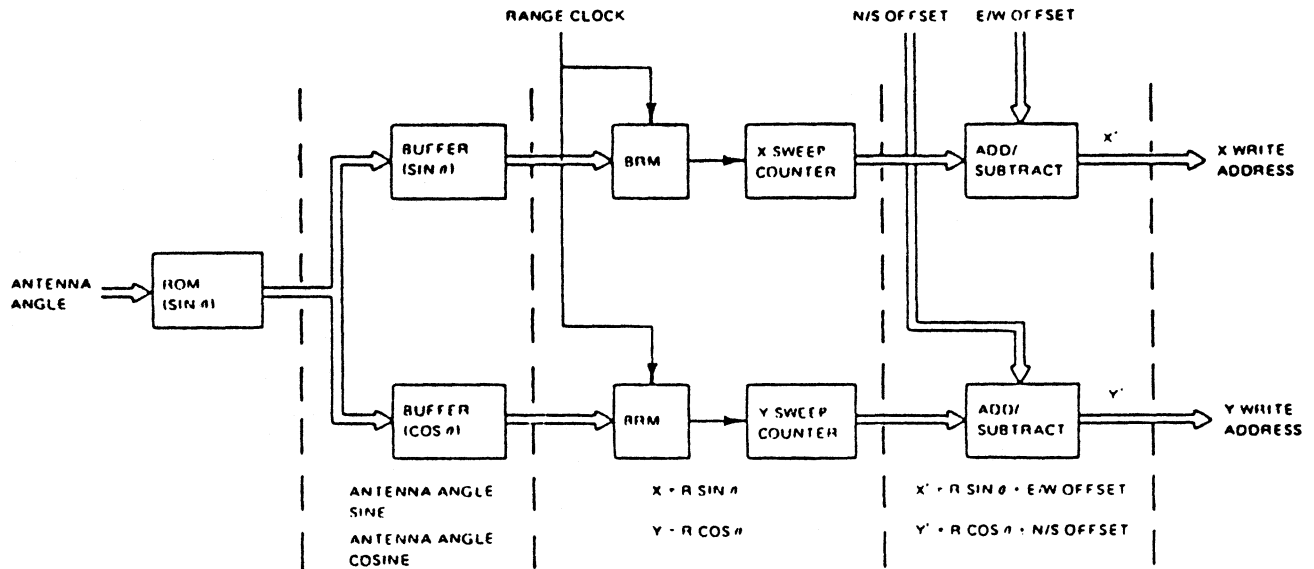

FIGURE 12. Write-Address-Generation.

format for the DSC memory. Polar to rectangular conversion requires generation of  $X=R \sin \theta$  and  $Y=R \cos \theta$ , where  $R$  represents radar range and  $\theta$  represents radar antenna azimuth. A read-only memory (ROM) is used to generate sine and cosine functions. Two binary-rate multipliers (BRMs) are used for multiplication by the radar range. Clock pulse outputs of the BRMs represent increments of  $X$  and  $Y$  target positions which are accumulated in counters. The capability of adding a translation in the  $X$  and  $Y$  directions permits implementation of scan-to-scan processing algorithms.

Organization of the DSC random access memory is an important consideration. One megabit (1 048 576 bits) of memory permits a display resolution of 512 by 512 cells with a video dynamic range of 16 levels (4 bits) (see Figure 13).

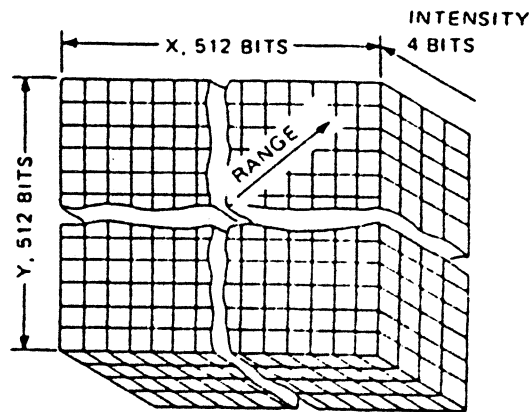

FIGURE 13. DSC Memory Organization.

Since 16 video levels exceed the 10 shades of grey normally achievable in a CRT display, the extra levels are available to store symbol and cursor data. To accommodate scan-to-scan integration, it may be desirable to extend video dynamic range by providing additional memory. Information from several radar scans is stored but only data integrating into the major bits is displayed, thereby excluding noise or clutter spikes which persist for insufficient time to integrate to full intensity.

The cost of the hardware to implement the DSC operations described above is approximately \$5000.00 [Burnham, 1982b]. Engineering design and implementation of a prototype for marine use would naturally require much more cost in manpower and time. Anyone attempting this task should have a strong background in radar signal processing. It is obvious that some of the components described here are already in use by modern ARPAs (see Appendix 2).

Appendix 3  
Display Technology

The most widely used medium (other than ink and paper) for information display is the CRT. From Figure 14 it can be seen that the market for CRT displays is more than 10 times that for other display types with the primary market (\$4 billion) being for television tubes. Both liquid crystal and plasma displays are presently being advanced to the point where they may become a viable alternative for electronic chart displays.

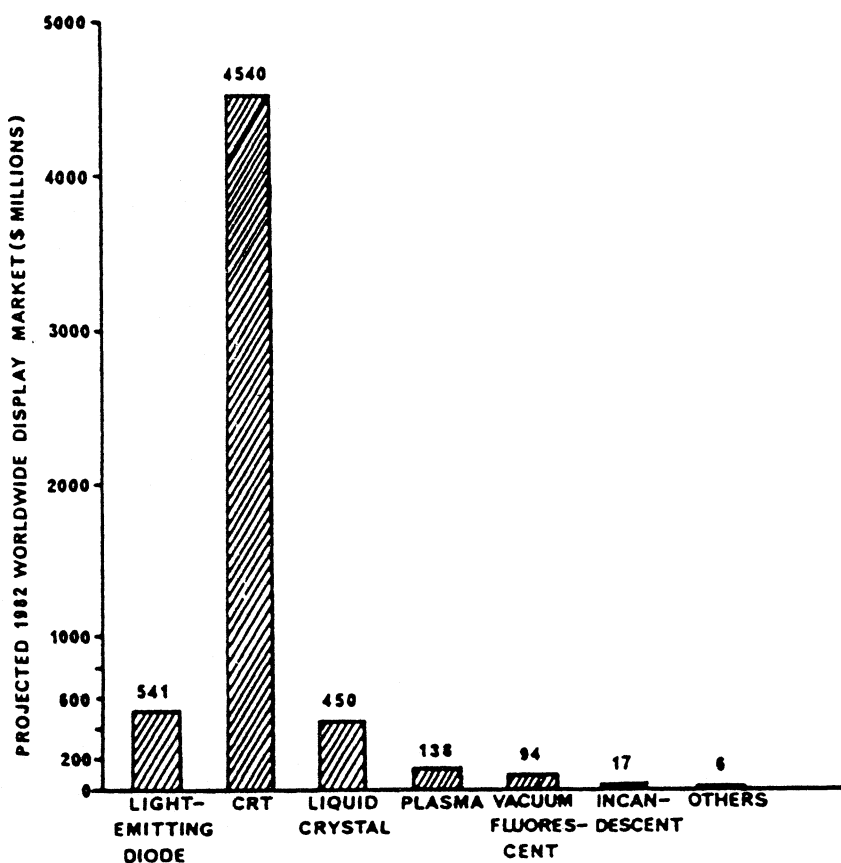

FIGURE 14. Electronic Display Market 1982 (from Suydam [1982]).

### A3.1 CRT fundamentals

Figure 15 shows the basic principle of an electromagnetic deflection type CRT. A ray or beam of electrons is emitted by the cathode when heated. The first and second anodes accelerate the beam which is focussed and deflected by other hardware. By having a large potential (usually 10 000 volts) applied to the second anode, the electron beam gains enough energy to excite the phosphor coating at a spot on the inside of the front of the tube. Varying the current (usually up to 400 microamperes) causes the phosphor to glow more or less brightly.

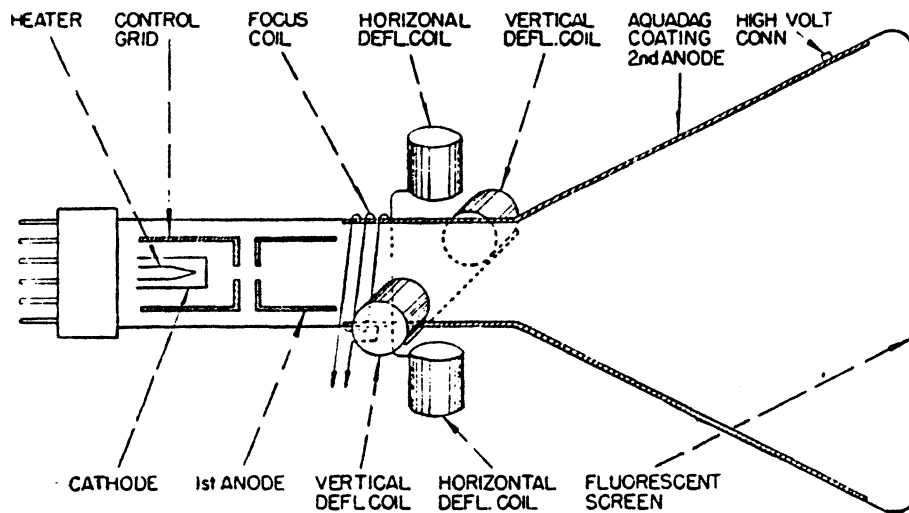

FIGURE 15. Basic CRT Construction (from Fowler and Lippert [1953]).

To understand the inherent resolution of CRTs, a quick look at television picture tubes (for which most CRTs are used) is helpful. North American black and white television scanning standards are defined as follows:

- (1)  $n = 525$  = total number of scanning lines per frame;
- (2)  $w/h = 4/3$  = width to height ratio;
- (3)  $H = 1/(525 \times 30) = 1/15\,750 = 63.5$  microsec = time between the beginning of one scanning line and the next;
- (4)  $V = 1/60$  = time between the beginning of one field and the next.

An interlaced scanning technique means that the odd numbered lines are

scanned first, then the even numbered lines (see Figure 16). This

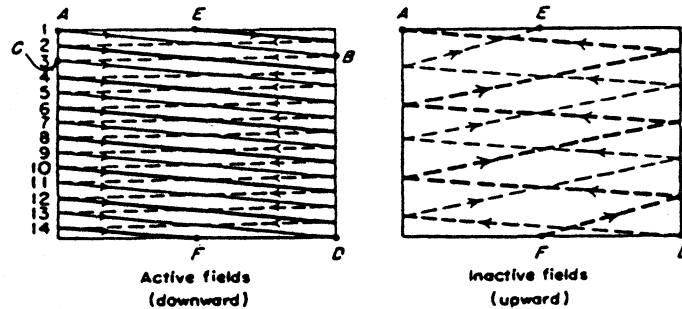

FIGURE 16. Geometry of the Interlaced Scanning Pattern (from Fink [1952]).

effectively doubles the scan rate to 1/60 of a second so that the picture does not appear to flicker.

The vertical resolution of raster television display tubes is limited to these broadcast 525 lines. About 35 of these are lost in the blanking interval when the beam is repositioned for the start of another field.

Horizontal resolution for a raster display is dependent on the frequency bandwidth of the CRT. Contrast variations or brightness levels are obtained by varying the electron beam intensity (see Figure 17). Horizontal resolution is determined by the maximum number of changes in intensity (current) which can occur as each line is scanned. As shown by Figure 18, the signal intensity must be able to change from top to bottom with a frequency capable of displaying the required resolution. For example, to resolve 512 picture elements, 256 complete cycles of the sine wave are needed. In addition, all 525 vertical lines must be scanned 30 times per second. This gives a minimum frequency of

$$f = \frac{256}{1/(525 \times 30)} = \frac{256 \text{ cycles}}{63.5 \cdot 10^{-6} \text{ sec}} = 4.03 \times 10^6 \text{ Hz} = 4.03 \text{ MHz}$$

necessary for a resolution of 512 picture elements. Only 83% (approximately) of the time is available for scanning due to synchronization and retrace functions. This increases the necessary frequency requirements. Normal television transmission is done within a 6 MHz bandwidth, with the video portion occupying 4.25 MHz. Normal television CRT displays are therefore built to handle this range of frequencies.

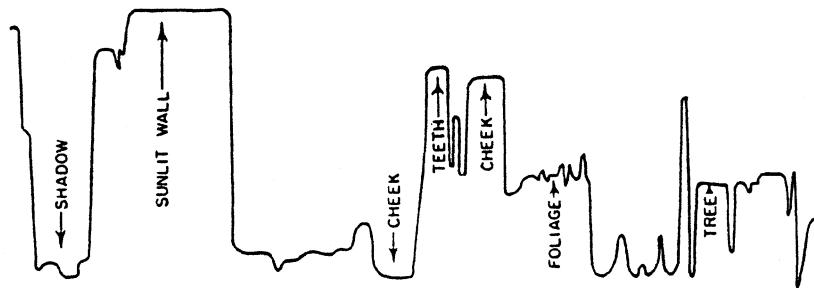
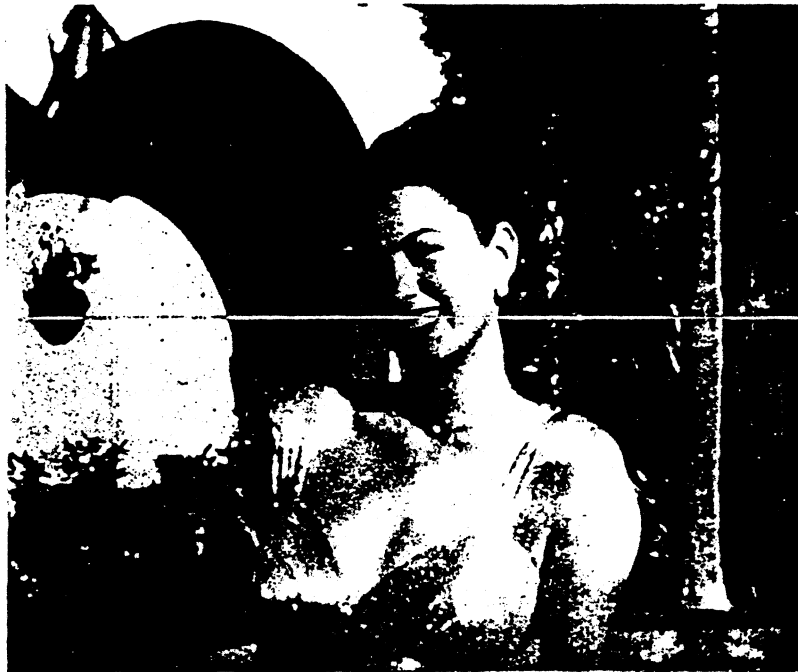

FIGURE 17. Scanning Technique (from Fink [1952]).

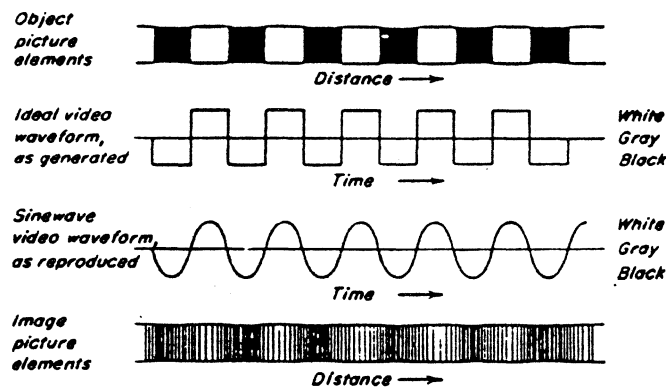

FIGURE 18. Horizontal Scan Resolution (from Fink [1952]).

In order to get a resolution of 1024 by 1024, the bandwidth must increase proportionally. The CRT must then be capable of a frequency response of

$$f = \frac{512}{1/(1024 \times 30)} = \frac{512 \text{ cycles}}{32.5 \text{ } \mu\text{sec}} = 15.75 \text{ MHz} .$$

Manufacturing the hardware for these high resolution CRTs is therefore more expensive and useable only in a monitor situation since television video signals are never wider than 4.25 MHz (in North America).

Colour CRTs operate with three electron guns (one red, one green, one blue), and are forced to focus on individual red, green, and blue (RGB) dot patterns on the inside of the face of the CRT. Resolution of colour CRTs is also somewhat dependent on the spacing of these RGB dot triads. Some recent specifications give a triad pitch (width) of 0.31 mm (0.012"), corresponding to 1083 triads in a 13" horizontal line [Hitachi, 1981]. Although relatively expensive (US\$7500.00), some 19 inch colour monitors are now available with a 40 MHz bandwidth and a pixel resolution of 1280 by 1024.

To compare this with standard 35 mm movies, the usual fine-grain film has a resolution of about 110 lines per mm. Due to loss of resolution in the printing and projection systems, the actual displayed resolution is roughly 60 lines per mm. With a standard frame aperture of 20.95 by 15.25 mm, this gives a frame of 1257 by 915 picture elements. Modern high resolution CRT monitors compare favourably with this figure.

### A3.2 Flat panel displays

In recent years, much research has been devoted to flat panel displays not using the conventional CRT approach. Liquid crystal displays (LCD) are already widely used for watches and calculators due to their very low power consumption. Problems arise when the number of pixels to be addressed becomes large. LCDs use reflected light for their contrast, and are therefore limited to two colours. IBM has recently announced a laser addressed 2000 x 2300 dot LCD for projection of images. Plasma panel displays are rapidly becoming more viable as a graphics display terminal. Figure 19 shows the basic idea behind it. The standard ac panel consists of



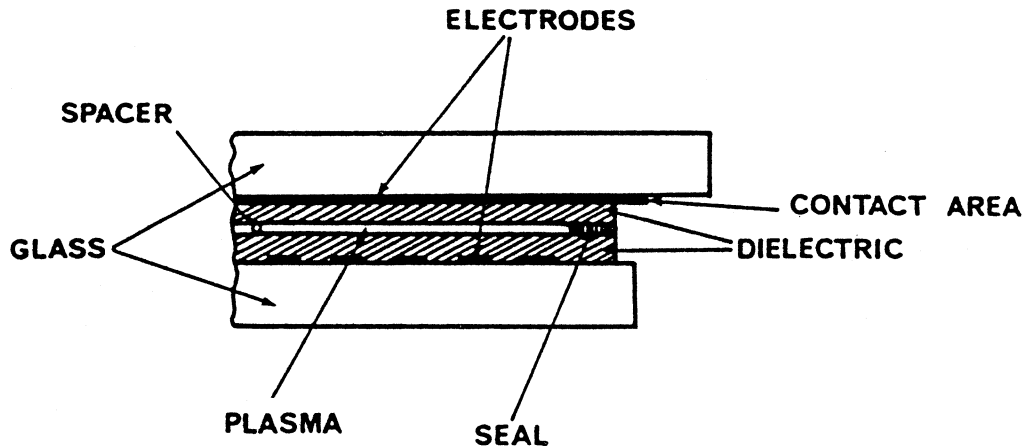

FIGURE 19. Plasma Panel Schematic.

two flat pieces of ordinary glass with electrodes and a dielectric layer deposited on them, held apart by spacers and hermetically sealed around the outside edges. The space between the glass is evacuated and filled with a plasma (a neon-argon or neon-xenon mixture) under a pressure of  $1/5$  to  $1/2$  atmosphere. A visible orange discharge occurs at the intersection of selected electrodes when the voltage applied between the electrodes exceeds the ionization voltage of the gas. Approximately 100 V charges are necessary to excite the plasma into discharging. Sony Corporation, Tokyo, have recently developed a 127 line per inch plasma panel capable of 512 by 1024 dots using 30 V drive circuitry. Photonics Technology, Ohio, now have a 1 metre (diagonal) plasma display capable of addressing 1200 by 1600 dots, with a thickness of five inches. Standard plasma displays are usually only two colours (orange and black).

In a recent announcement [Electronics, 2 June 1982, p.90], Siemens AG of Munich has married the best of both plasma and CRT technology to produce a 14 inch (diagonal) full colour display only  $2 \frac{1}{4}$  inches thick. The plasma is used as a source of electrons, rather than being the light source, and these electrons are pulled to a matrix of anodes and control electrodes and then accelerated through a space 1 mm wide toward the phosphor screen. The voltage (0 - 50 V) at the control electrodes determines the brightness of the picture. Acceleration voltage is 4 KVolts. The display has a resolution of 720 by 448 pixels, which corresponds to West German television standards. Both brightness and contrast compare favourably with standard colour CRT displays. Due to the short acceleration distance of 1 mm, the

electrons always land on the same spot, which means that very little distortion will occur for graphics applications.

This discussion points out that electronic technology is pushing display technology advancements significantly. Smaller, more rugged, and less power-hungry displays with high resolution will undoubtedly be available for electronic chart display in the near future.

### A3.3 Display of graphics

Graphic information is almost always stored as coordinate values with respect to some local X, Y plane grid. This makes possible the easy identification of lines, points, symbols, and polygons. As well the data is device independent. The Canadian Telidon videotex system [Bown et al., 1980] uses a Position Description Instructions (PDI) coding scheme which is device independent by virtue of this technique (data is handled in television pages instead of a continuous chart mode).

Most modern computer graphics terminals are using raster displays on (usually) high resolution colour CRT monitors. Each pixel addressed on the CRT must have at least one bit to define whether it should be on or off. More than two colours or gray levels require more bits per pixel (e.g., 2 bits = 4 colours, 3 bits = 8 colours, 4 bits = 16 colours). Graphics memory to hold 1024 x 1024 pixels with up to 8 colours defined would require 3 bit planes of 1 MBit each or a total of 384 KBytes. This is only 12 memory chips using the 256 KBit density now (1982) coming into production.

This graphics memory is only the bit map for the pixels to be displayed on the CRT. As shown in Figure 20, conversions must take place to get the

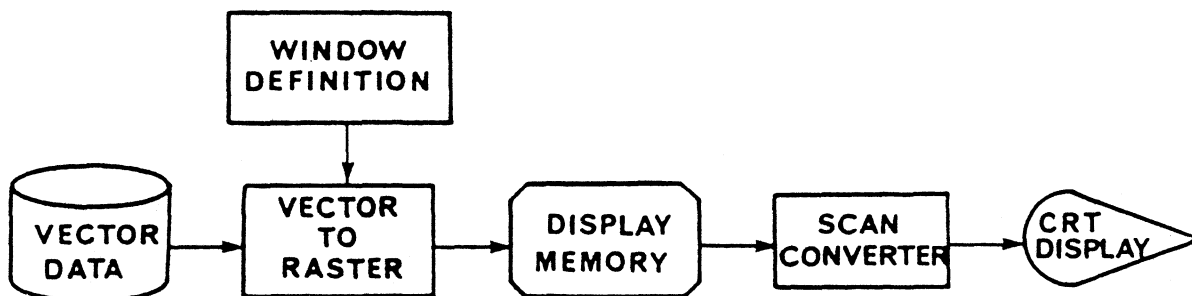

FIGURE 20. Plotting of Graphic Data.

vector data into raster, and the raster into analog form for the scanning system of the CRT. For the direct view storage tube graphics terminal (i.e., Tektronix 4010 series), the CRT gun does not scan as in the television CRT, but is directed by the actual screen coordinates coming from a display controller.

The raster scanning technique of television type CRT displays have the capability to be refreshed or changed at 30 times per second so that movement of the data being displayed is easily done. The storage tube CRT must normally erase the entire screen to change any portion of the display.

Appendix 4  
IFR Electronic Charts

A4.1 IFR Analogy

Some air transport industry aircraft flying with flight management computers now have the equivalent of their IFR chart available on a transportable electronic medium readable only by computer. Figure 21 shows the basic routes available for an individual airline (A/L) to obtain the

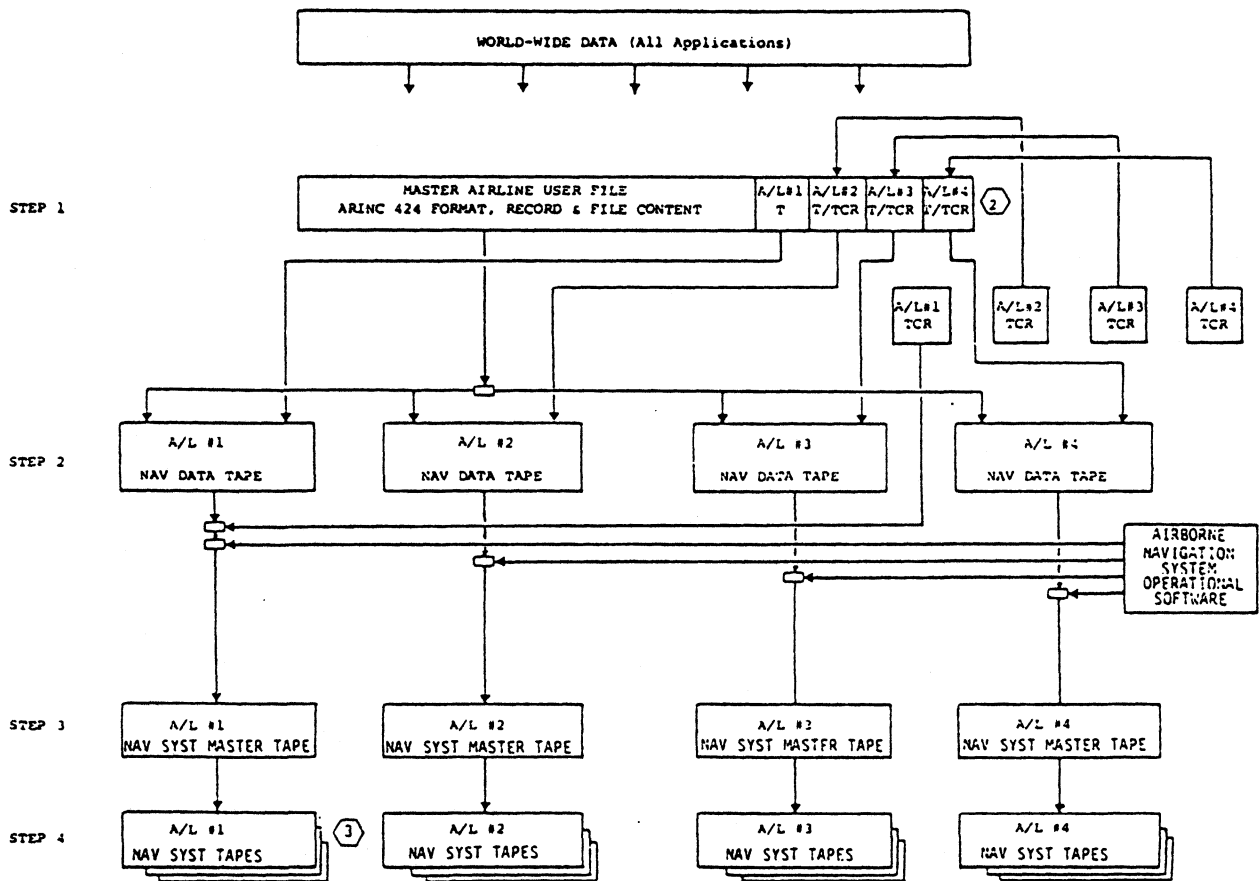

FIGURE 21. Aircraft Electronic IFR Chart Generation  
(from ARINC [1980]).

data on the master airline user file, and to merge it with tailored company route (TCR) data to obtain navigation system tapes ("tapes" implies transportable storage media only) for individual aircraft. Data format

specifications for levels 1 and 2 of the files are set down in Aeronautical Radio Incorporated (ARINC) Specification 424-1, 1980. Data is organized as records, with each record composed of a number of fields. A collection of records of functionally similar data items forms a sub-section, groups of which form sections, the first level database division. Table 6 shows the

<u>Section Code</u>	<u>Section Name</u>	<u>Sub-section Code</u>	<u>Sub-section Name</u>
D	Navaid	Blank B	VHF Navaid NDB Navaid
E	Enroute	A P R	Waypoints Holding patterns Enroute airways
P	Airport	A B C D E F G I	Reference point Airline gates Terminal waypoints SIDs STARs Approach routes Runways ILS/G.S. data
R	Company Routes	Blank	

TABLE 6. Sections and Sub-Sections of the IFR Navigation Database.

primary subdivisions. All records contain 132 characters (bytes) of data, and may be continued onto another record. As an example, Table 7 shows the Airport Reference Point record format. All of the data in the records is coded as character data. For example, the magnetic bearing to a specified waypoint is coded as 4 integers in units of tenths of a degree. Drawing of a line on the cockpit display joining two points is done by the computer which is reading and interpreting the database. All point coordinates are stored as latitude and longitude to the nearest 1/100 of an arcsecond. The data contained in this database is exactly the same as that contained on the paper IFR chart.

As an example of what a cockpit display of this information looks like, Figure 22 has been taken from Burnham [1982]. The diagrams are generated from the database character data and consist primarily of straight lines,

arcs of circles, alphanumerics, and special symbols.

#### 4.7.1 Primary Records

Column	Field Name (Length)	Reference
1	Record Type (1)	5.2
2 thru 4	Customer/Area Code (3)	5.3
5	Section Code (1)	5.4
6	Blank (Spacing) (1)	
7 thru 10	Airport ICAO Identifier (4)	5.6
11 thru 12	ICAO Code (2)	5.14
13	Sub-section Code (1)	5.5
14 thru 21	Blank (Spacing)	
22	Continuation Record No. (1)	5.16
23 thru 27	Speed Limit Altitude (5)	5.73
28 thru 29	Airport Class (2)	5.54
30 thru 32	Blank (Spacing) (3)	
33 thru 41	Airport Reference Pt. Latitude (9)	5.36
42 thru 51	Airport Reference Pt. Longitude (10)	5.37
52 thru 56	Magnetic Variation (5)	5.39
57 thru 61	Airport Elevation (5)	5.55
62 thru 64	Speed Limit (3)	5.72
65 thru 93	Reserved (Expansion) (29)	
94 thru 123	Airport Name (30)	5.71
124 thru 128	File Record No. (5)	5.31
129 thru 132	Cycle Data (4)	5.32

#### 4.7.2 Continuation Records

Column	Field Name (Length)	Reference
1 thru 21	Fields as on Primary Records	
22	Continuation Record No. (1)	5.16
23 thru 92	Notes (70)	5.61
93 thru 123	Reserved (Expansion) (30)	
124 thru 128	File Record No. (5)	5.31
129 thru 132	Cycle Date (4)	5.32

TABLE 7. Airport Reference Point Record Definition.

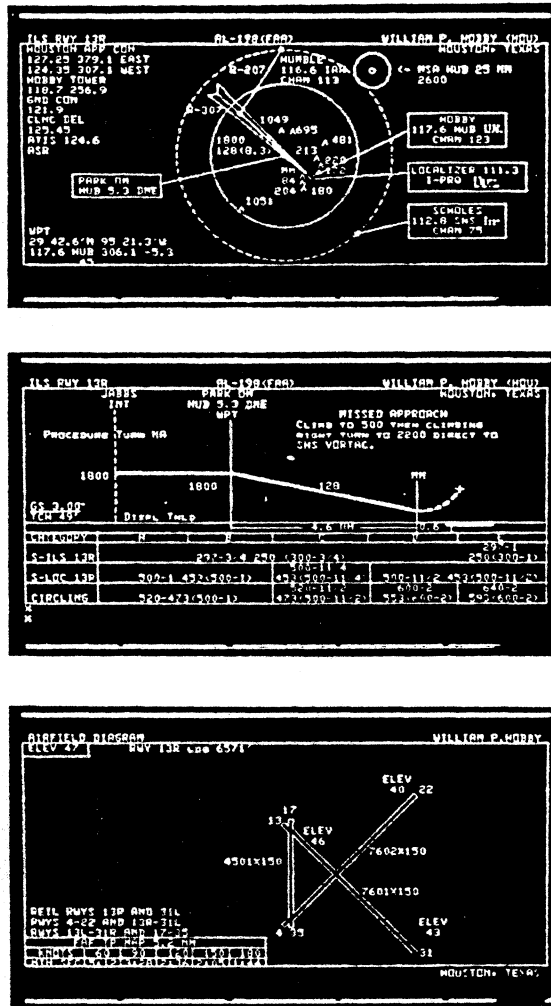

FIGURE 22. Sample Cockpit Displays of Navigation Database Information (from Burnham [1982]).

To carry a similar system into the marine world seems to make sense for the larger (and busier) ports. Schematic displays of vital information such as communication frequencies, channel markers, rough coastlines, minimum depths, and harbour traffic patterns would aid in busy ports, particularly if this information were superimposed on the radar, or if interpreted radar echoes were superimposed on another display containing this data.

The analogy is not complete since there is as yet no specified IFR equivalent in the marine world. However, as it is only a few decades since aviation operated entirely under Visual Flight Rules, it is not unrealistic to anticipate a similar, though slower, evolution in the marine world.