

# **PHOTOGRAMMETRY FOR CIVIL AND FOREST ENGINEERS**

**E. E. DERENYI**

**October 1982**



**LECTURE NOTES  
NO. 55**

# **PHOTOGRAMMETRY FOR CIVIL AND FOREST ENGINEERS**

E. E. Derenyi

Department of Geodesy and Geomatics Engineering  
University of New Brunswick  
P.O. Box 4400  
Fredericton, N.B.  
Canada  
E3B 5A3

October 1982

## PREFACE

In order to make our extensive series of lecture notes more readily available, we have scanned the old master copies and produced electronic versions in Portable Document Format. The quality of the images varies depending on the quality of the originals. The images have not been converted to searchable text.

## PREFACE

These notes provide an overview on photogrammetry without going into technical details. Some simple operations, that civil and forest engineers can perform themselves, are discussed at some length.

An attempt is made to answer three questions about photogrammetry which will occur to a civil or forest engineer:

- What can it do?
- How accurately?
- What is involved?

With the knowledge gained, civil and forest engineers should be able to utilize photogrammetry to their advantage and should be able to communicate more readily with specialists in this field.

## 1. INTRODUCTION

Photogrammetry is the science of obtaining reliable measurements by means of photography, for the purpose of determining the position, size, shape of the photographed object. The aim of photogrammetry is analogous to that of field survey operations, however, the measuring techniques are different. A surveyor must be in physical contact with the features he is measuring or at least with their surroundings. He must perform all the measurements necessary for the completion of the project in an "on-line" mode, meaning while he is physically present at the scene. A photogrammetrist on the other hand operates in an "off-line" mode, he may be thousands of miles away from the scene when most of the measurements are performed. He practices surveying by remote sensing. Figure 1-1 draws a parallel between field surveying and photogrammetry.

Photogrammetry offers several advantages over field surveying techniques, such as:

1. Field work itself requires only a short time, an important factor especially when the surveyors' interference with industrial production must be minimized.
2. Difficulties encountered in surveying inaccessible features are largely eliminated.
3. The actual measuring process consist of the evaluation of the photographs, and can be performed when and where convenient.
4. Photographs serve as a data storage, much richer in content than any surveyor's note book. Therefore it is sufficient to make the final selection of points and features to be measured at the time of the evaluation of the photographs rather than in the field.

Additional measurements and check measurements can be made at any time, even after the scene photographed has changed.

5. Photography is capable of recording a situation as it exists at a particular moment of time. Therefore, it is particularly suitable for monitoring rapid changes.
6. Data collection by photogrammetric means lends itself very well to digital data collection, storage, retrieval and display techniques.

However, there are certain disadvantages as well:

1. Equipment is more expensive and a much larger initial capital investment is necessary.
2. It is uneconomical to employ photogrammetry for small survey projects.
3. For aerial photogrammetry specialised staff and equipment is needed (aircraft, pilot navigator, etc.).
4. Data acquisition in the field (taking of the photos) requires favourable conditions and must be accomplished during the appropriate time of the year.
5. While the field survey approach is completely self sufficient, photogrammetry needs a certain amount of ground control established by field survey means.

All survey projects should be pre-analysed and the most suitable and economical method be selected for the execution.

Photogrammetry can be classified into branches in various ways:

(a) According to the data acquisition system used:

- Terrestrial
- Aerial
- Space

(b) According to the evaluation method employed:

- Analytical
- Semi-analytical
- Analogue

(c) According to data handling:

- Single image
- Double image (stereo)

(d) According to the application:

- Topographic
- Non-topographic

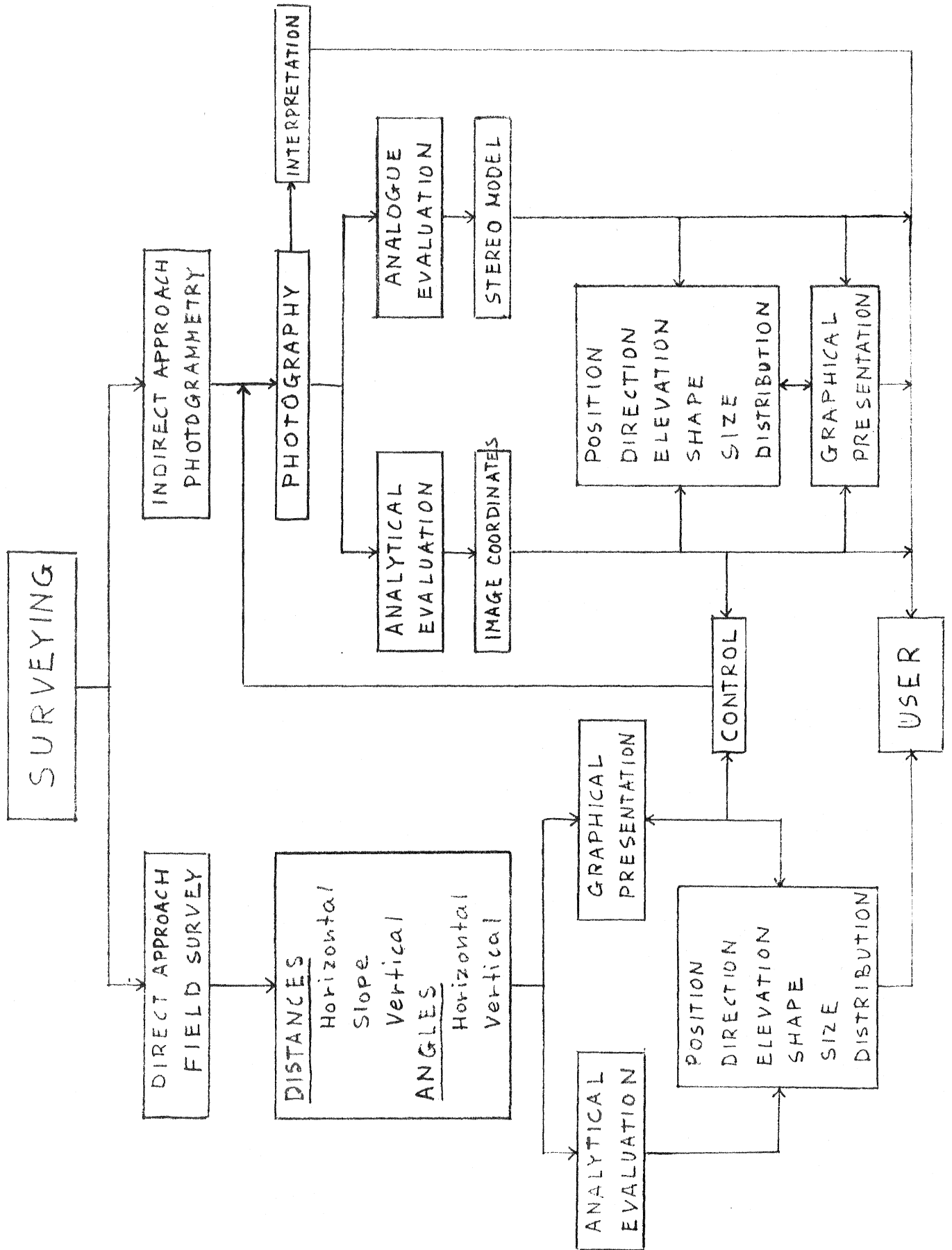

Figure 1-1.



## 2. BASIC PRINCIPLES

### 2.1 The Projection

The most important difference between a map and a photograph is that the map is an orthographic projection while the photograph is a central projection or central perspective (Figure 2-1).

Orthographic projection means that the object is projected onto a plane in a certain uniform scale by rays perpendicular to that plane. The plane in question is usually parallel to a predetermined reference or datum plane.

In case of a central projection all rays pass through a common point called the projection or perspective centre. Central projections are independent of datum planes. They may be horizontal, vertical or tilted.

Consequently, a central projection (photograph) has the same geometric characteristics as a map only if the object is a plane (two dimensional) and if the image plane and the plane of the object are parallel to each other. If the object is three dimensional then height (relief) displacements occur (Figure 2-2). If the image plane and the object plane are not parallel then tilt displacements occur. In both cases the scale of the image will not be uniform but variable. The main task of photogrammetry is to produce maps from photographs or in other words to transform the central projection into an orthographic projection.

The geometry of the central projection inside the camera is defined by the interior orientation elements. Interior orientation establishes the relationship between the interior projection or perspective centre and the image plane (Figure 2-3).

- Interior projection centre is the optical centre of the lens from where rays diverge toward the image plane.

- Exterior projection centre is the optical centre of the lens to where rays on the object side converge.

The interior orientation elements are (Figure 2-3):

- Principal point, which is the foot of the perpendicular from the interior projection centre to the image plane.
- Principal distance, which is the distance from the interior projection centre to the principal point.

The location of the principal point can be established by the intersection of lines connecting opposite fiducial marks. Camera fiducial marks are index marks rigidly connected to the focal plane frame either at the mid point along the side, or in the corners. The images of these marks appear on the photographs (Figure 2.4). Lines joining opposite fiducials also provide a rectangular coordinate system, referred to as image or photo coordinate system, for defining the position of image points. The positive x axis usually points in the direction of the base.

When a camera is focused to infinity, then the value of the principal distance is practically equal to the focal length of the camera lens.

The principal distance ( $f$ ) and the image format size govern the angle of view ( $\alpha$ ) of the camera. Most aerial survey cameras have an image format size of 230 mm x 230 mm, which gives a diagonal of 325 mm long.

The four principal distances used for mapping cameras and the corresponding angles of view are (Figure 2-5):

$f = 305$ mm	$\alpha = 55^\circ$ , Narrow angle
210 mm	$75^\circ$ , Normal angle
152 mm	$90^\circ$ , Wide angle
90 mm	$120^\circ$ , Super-wide angle

The wide angle camera is the one most commonly used. The others are used for special purposes e.g., narrow and normal angles for urban areas;

super-wide angle for mapping large areas at small scale (Figure 2-6).

The relationship between the image plane and the datum plane of the object is established by the exterior orientation. The elements of exterior orientation are (Figure 2-7):

- Location  $(X_o, Y_o, Z_o)$  of the exterior projection centre with respect to the object space coordinate system.
- Direction  $(\omega, \phi, \kappa)$  of the optical axis of the camera with respect to the object space coordinate system.

The direction of the optical axis is usually defined by three components:

- $\omega$  is the rotation around the X-axis;
- $\phi$  is the rotation angle around the Y-axis;
- $\kappa$  is the rotation angle around the Z-axis.

## 2.2 Scale of a Photograph

Scale of a photograph can be determined as the ratio

$$\frac{\text{distance on the photograph}}{\text{distance in object space}} \quad \text{or}$$

$$\frac{\text{principal distance}}{\text{distance from camera to object point}}$$

For aerial photographs the latter becomes

$$\text{Scale} = \frac{f}{H - h},$$

where  $H$  is the flying height above a datum, usually sea level;  $h$  is the height of a terrain point above datum (Figure 2-8).

With the exception of flat terrain,  $h$  is variable, hence the scale will also be variable. When  $h$  is taken as the average height of the

terrain,  $(H-h)$  becomes the average flying height above terrain and the average scale of the photograph is obtained.

Tilt of the photograph will further modify the value of scale and contributes to the fact that scale is not constant over the whole photograph.

### 2.3 Relief Displacement

Relief displacement is the shift in the position of an image point on the photograph caused by the elevation of the object above or below a selected datum. The displacement occurs radially outward from the principal point for objects situated above the datum and inward for objects below the datum (Figure 2-9). The magnitude of relief displacement is given by the following equation (Figure 2-10):

$$d = \frac{r h}{H} ,$$

where  $d$  is the relief displacement;  $h$  is the height of the object with respect to the selected datum;  $r$  is the radial distance on the photograph measured from the principal point to the displaced image and  $H$  is the flying height above the datum.

The relief displacement equation can be rearranged to calculate vertical heights of objects, whereby

$$h = \frac{d H}{r} .$$

This equation is useful for determining the height of objects above ground. The answer is only approximate because of the effect of tilt and because the exact value of  $H$  is usually not known.

## 2.4 Tilt Displacement

Tilt displacement occurs if the image plane is not parallel to the datum plane of the object; in other words if the camera axis is not perpendicular to the datum plane (Figure 2-11). Tilt displacements are inward or outward from the centre of the photograph depending on which side of the tilt axis is the point located (Figure 2-12). Tilt displacements occur even on photos taken over flat ground.

Mapping photography is normally taken with the optical axis of the camera in a vertical orientation. Due to the angular oscillation of the aircraft, however, small amount of tilt inevitably occur. Such tilt is less than  $1^{\circ}$  in most cases and seldom exceeds  $3^{\circ}$ .

- Truly vertical photograph is the one taken with the optical axis of the camera exactly vertical;
- Vertical photograph is the one taken with the optical axis of the camera tilted unintentionally by up to  $3^{\circ}$ .

Sometimes aerial photographs are taken with the optical axis of the camera intentionally inclined at an angle to the vertical. These photos are called oblique photographs. Oblique photos provide a larger ground coverage and better overview of the terrain but are more difficult to analyse numerically (Figure 2-13).

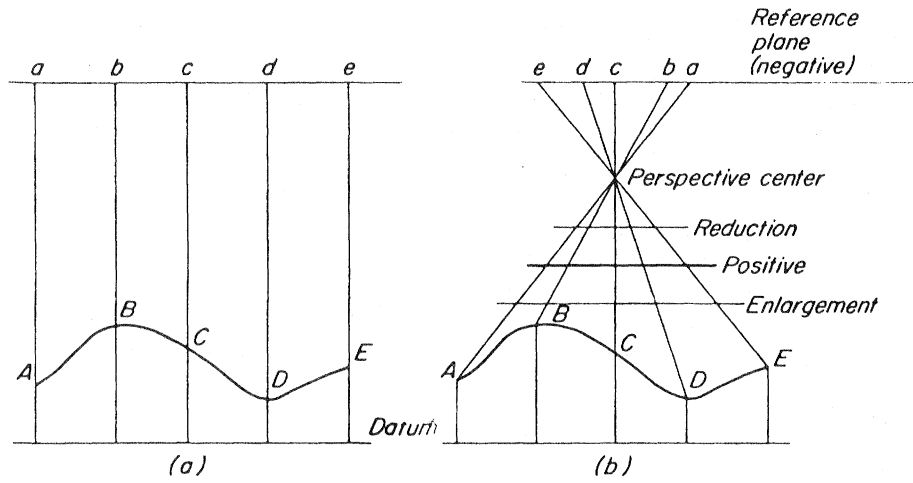

Figure 2-1. Orthographic vs perspective projection.

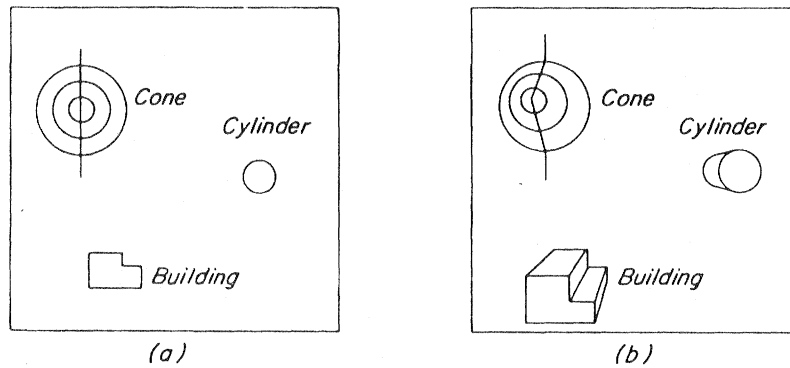

Figure 2-2. Idealized objects in orthographic and perspective projection.

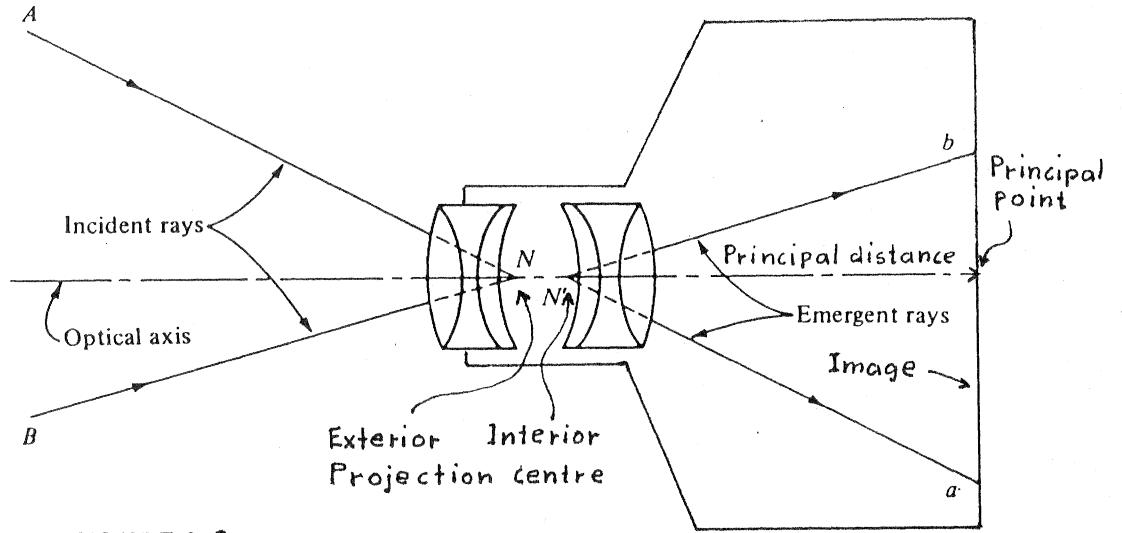

FIGURE 2-3.

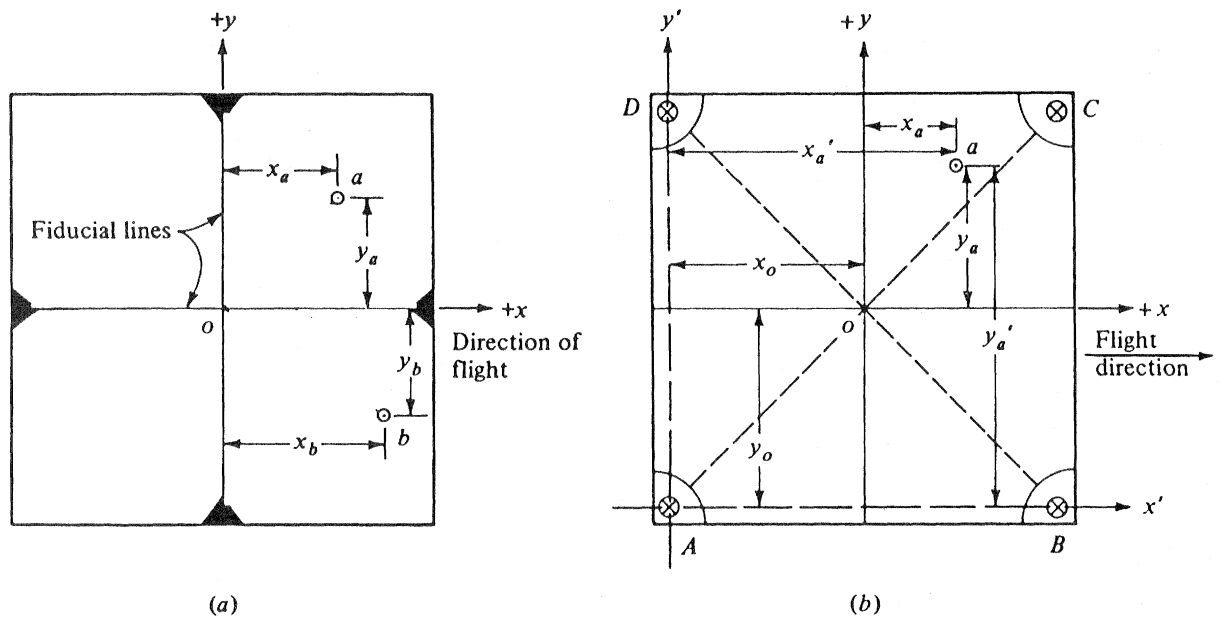

FIGURE 2-4.

Photographic coordinate system. (a) Side fiducials; (b) corner fiducials.

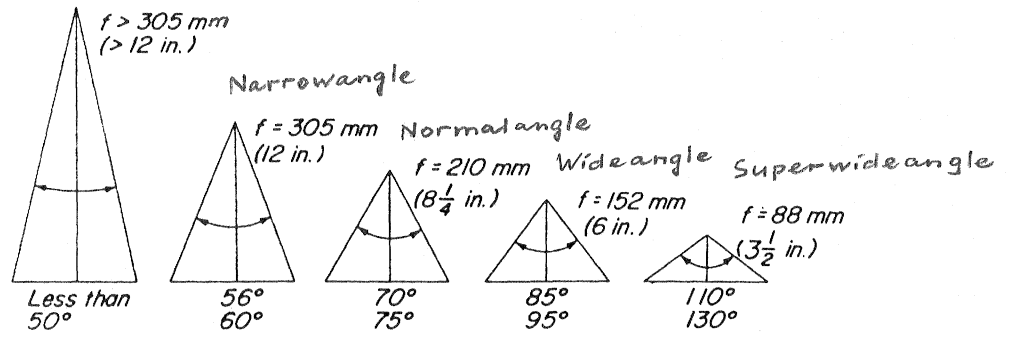

Figure 2-5. Relation between field angle and focal length.

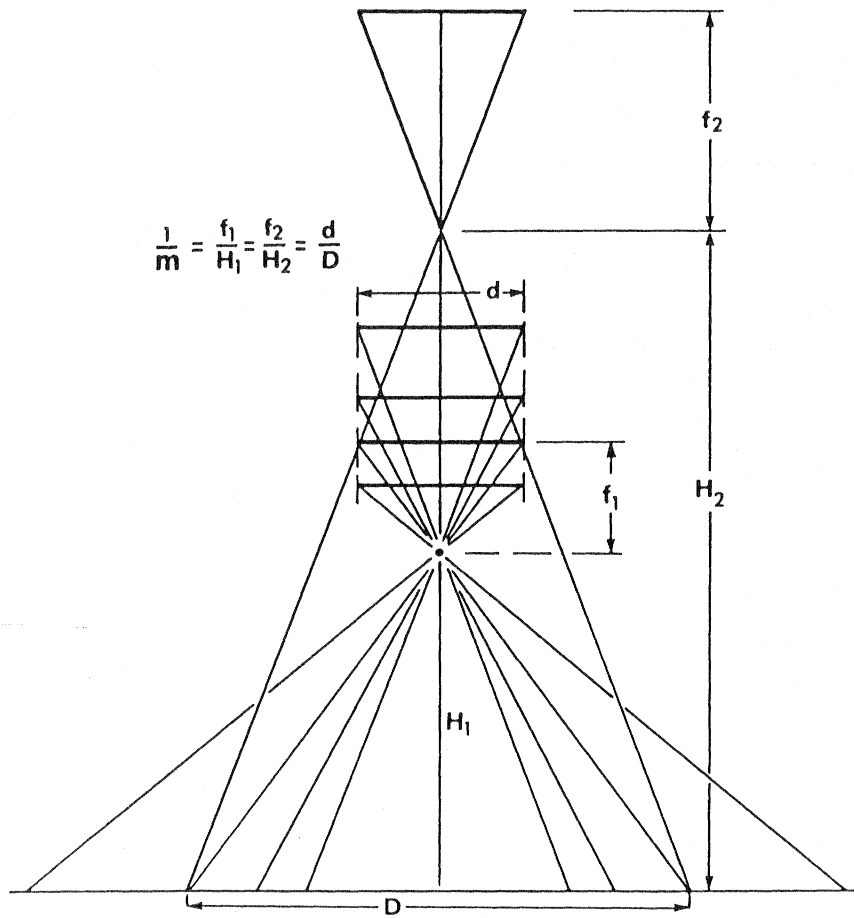

Figure 2-6. Angle of camera's field of view and the resulting ground coverage.



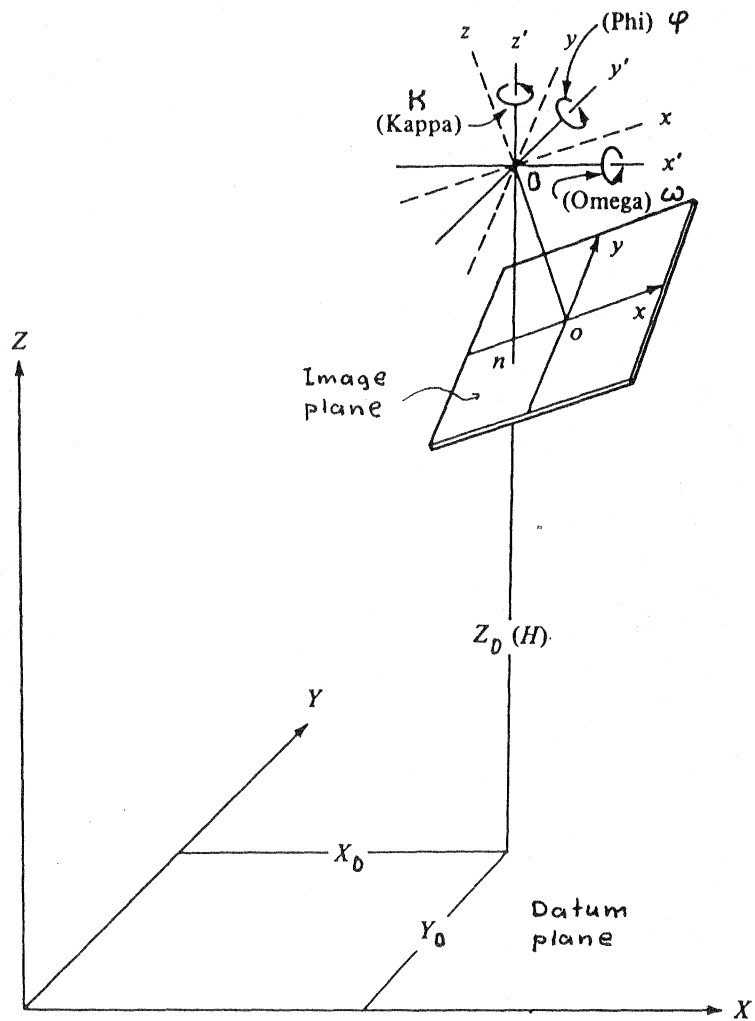

FIGURE 2-7.  
Orientation of a tilted photo in the omega-phi-kappa system.  
Exterior orientation.

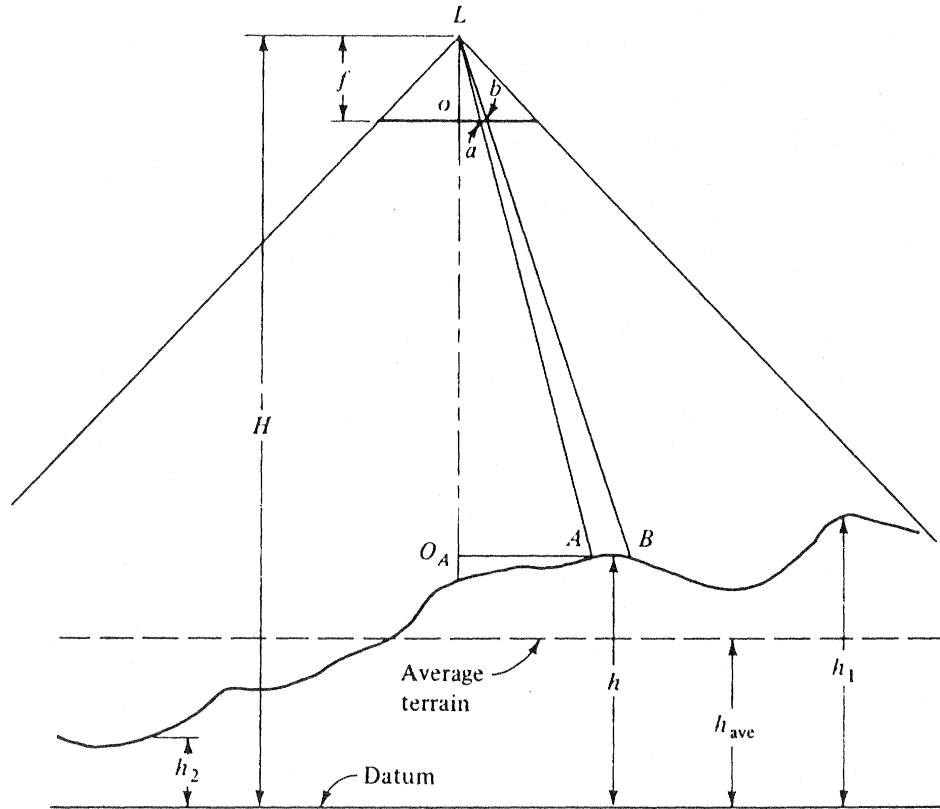

FIGURE 2-8.  
Scale of a vertical photograph over variable terrain.

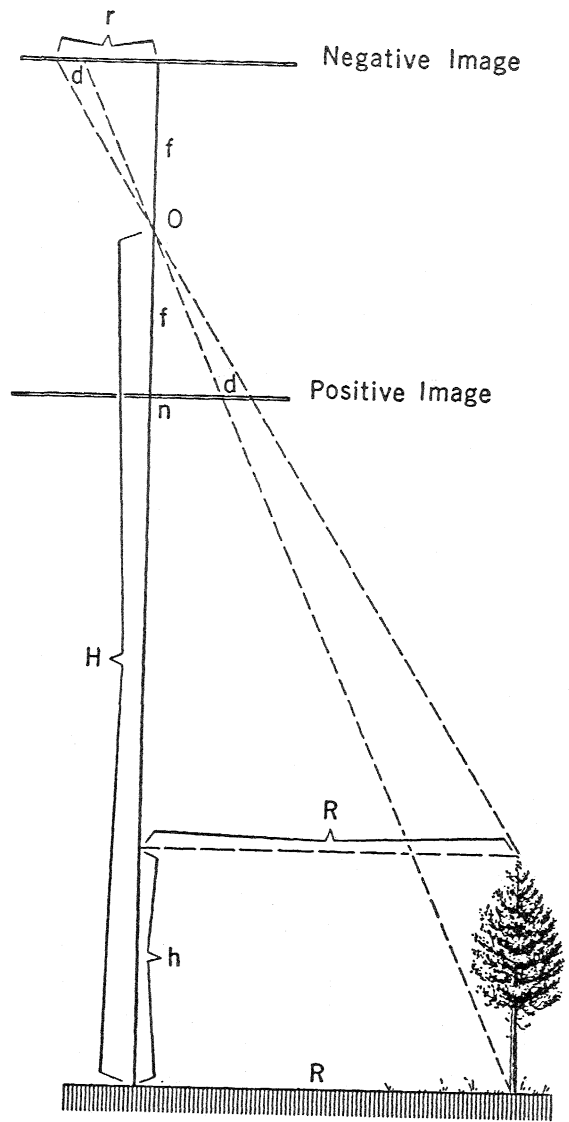

Figure 2-10, Displacement in single aerial photograph due to elevation.

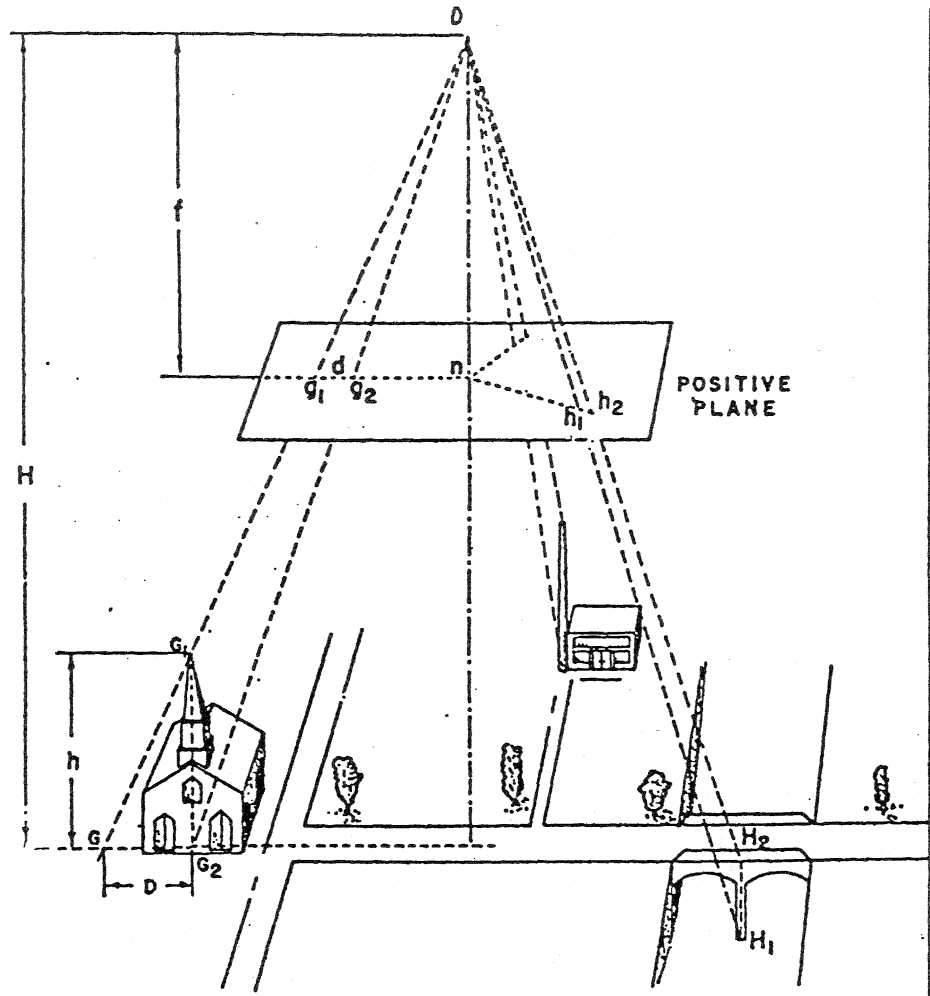

Figure 2-9.

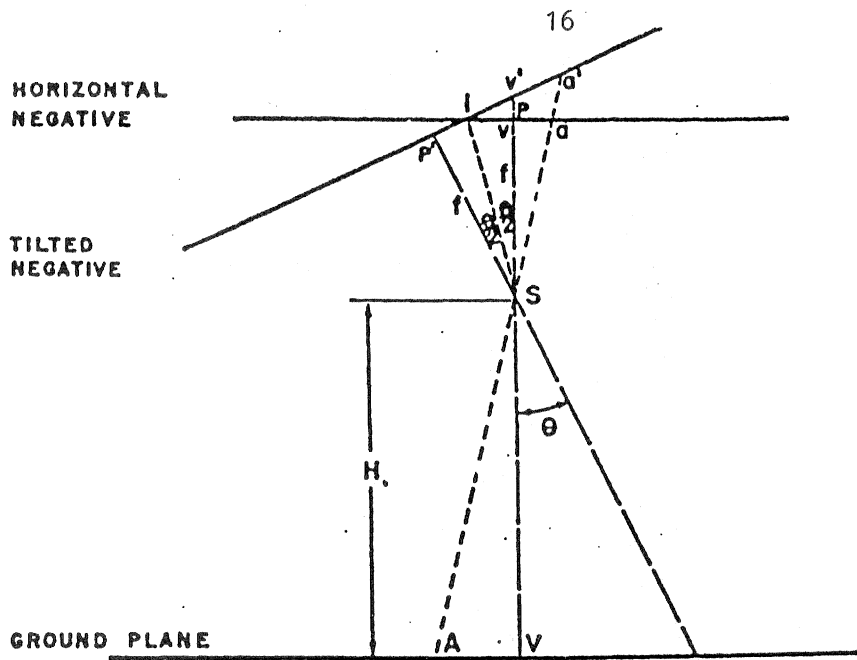

FIGURE 2-11.  
 DIAGRAM TO ILLUSTRATE TILT IN A PHOTOGRAPH

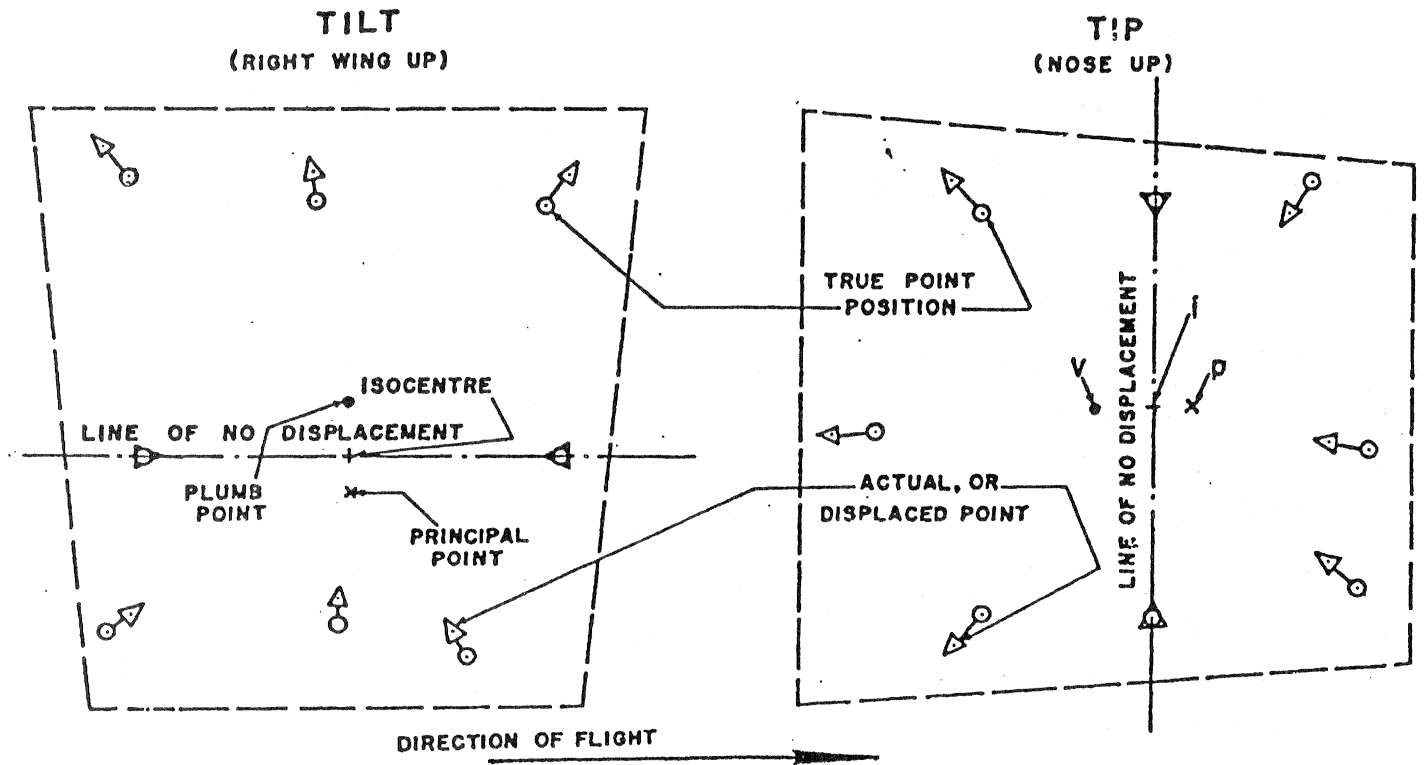

FIGURE 2-12.  
 DISPLACEMENT DUE TO TILT AND TIP  
 IN A PHOTOGRAPH  
 (POSITIVE PLANE)

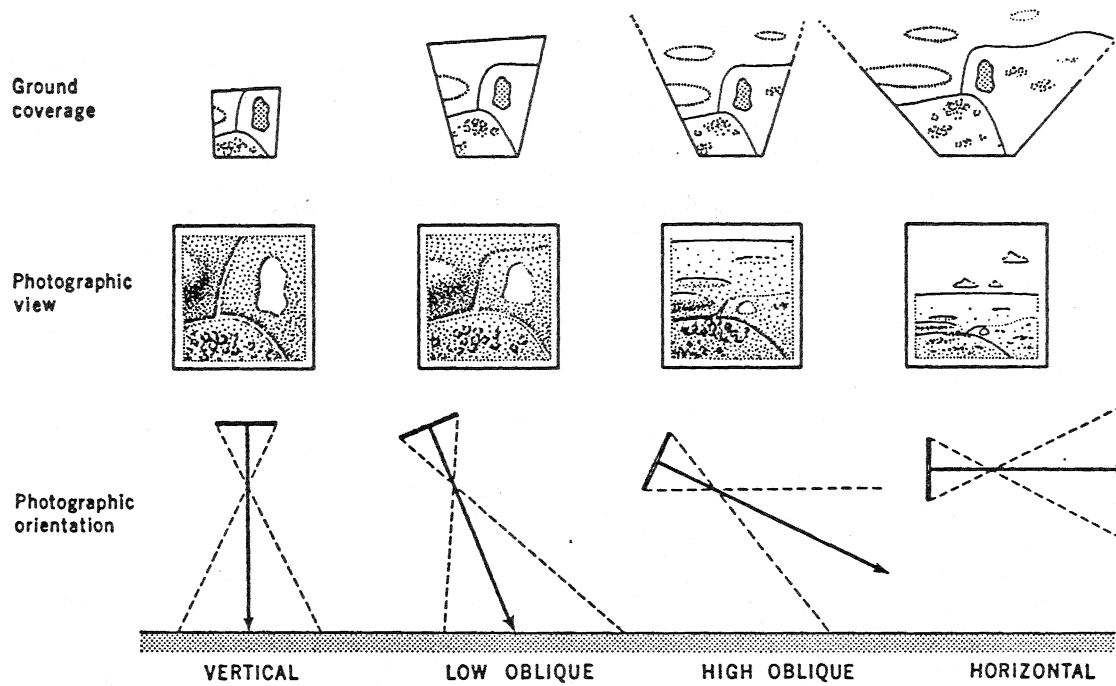

Figure 2-13 Characteristics of vertical and oblique photographs.

### 3. SINGLE IMAGE PHOTOGRAMMETRY

A photograph does not have the same geometric qualities as a map because of relief and tilt displacement. Thus a single photograph can only be regarded as a map substitute and may be used as such when the inherent errors can be neglected. On the other hand, photographs often show a more up-to-date record of the terrain than maps and are invaluable aids especially in the field of planning.

There are certain methods by which the inherent distortions of a photograph can be reduced or eliminated.

#### 3.1 Rectification

Rectification is the process of transforming a tilted photograph into an equivalent truly vertical photo. A scale change can also be introduced. Instruments used for this process are called rectifiers. A rectified photo is free of tilt displacement but still contains image displacements due to relief. It remains a central projection.

Rectifiers operate on the principle of projection printing. The main components are: the illumination system, the negative holder, the projection lens and the easel or projection table (Figure 3-1). Rectification is performed in the following way:

Four control points are plotted at the scale desired for the rectified photo. Next the plot is placed on the easel and by manipulating the various controls of the instrument the projected images of the control points are made to coincide with the plotted points. The control sheet is then replaced by photographic paper and exposed.

The effect of tilt can also be reduced by the use of simple "reflection instruments". These instruments operate on the "camera Lucida" principle. The viewing system contains a semi-transparent mirror or prism whereby the photograph and a map or control sheet can be viewed simultaneously (Figure 3-2). With the help of various adjustment facilities such as tilting the photo holders, changing the viewing distance, shifting and rotating the map sheet, photo points can be matched up with the corresponding map points or plotted control points. Planimetric details can then be traced from the photo onto the map or a drawing sheet. Instruments based on this principle are the vertical sketchmaster, rectoplanograph, Zoom Transfer Scope, etc.

Such instruments can be used for updating existing maps or to transfer interpreted details from photograph to a map.

### 3.2 Differential Rectification

In the differential rectification process the rectified photo is exposed sequentially in small area elements and during this process the displacement due to relief is also eliminated (Figure 3-3). The instrument used for this purpose is the orthophotoscope and the product is called orthophoto. The orthophoto is an orthogonal projection with the appearance of a photograph (Figure 3-4).

### 3.3 Photo Maps and Mosaics

Two or more aerial photographs can be assembled to form a single continuous picture of an area. Such assembly is called aerial mosaic (Figure 3-5). Photos assembled into a map sheet format and cartographically enhanced form a photo map (Figure 3-6).

The geometric characteristics of the assembly depends on the geometric characteristics of the individual photographs and on the method used for the assembly. One can distinguish between:

- Uncontrolled mosaics which are prepared by simply matching the image details of adjacent photographs.
- Semicontrolled mosaics when some ground control points are available to reduce the propagation of errors in joining the photos and/or the mosaic is scaled.
- Controlled mosaics are prepared from rectified photos of uniform scale and are assembled onto a network of horizontal control points.
- Rectified photo map is a controlled mosaic arranged in a map sheet format and annotated.
- Orthophoto map consists of orthophotos joined together to form an annotated map sheet.

Note that orthophotos and orthophoto maps have the same geometric characteristics as a line map (orthogonal projection) but contain all the information that appears on the original aerial photo.

Mosaics and photomaps have distinct advantages over line drawn maps. They are invaluable in land-use planning and in planning for large engineering projects. A line map is an edited representation of the terrain; only certain features are transferred from the photograph. Photomaps show the study area comprehensively and critical features which would affect the project such as drainage patterns, geologic features, land-use, vegetation cover can be more accurately assessed. These products are also useful to inventory natural resources. Laypersons can relate much easier to photomaps than to line maps.



A disadvantage of photomaps is that topographic information and annotations are more difficult to add and may saturate the content. Some people also object to the fact that it is difficult to make notations or design drawings on them. It is also difficult to update photomaps.

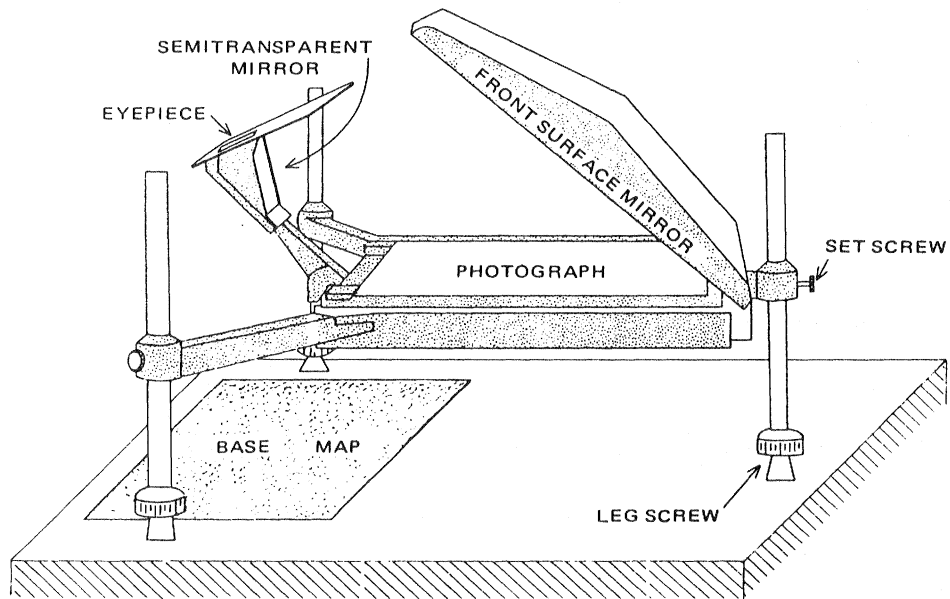
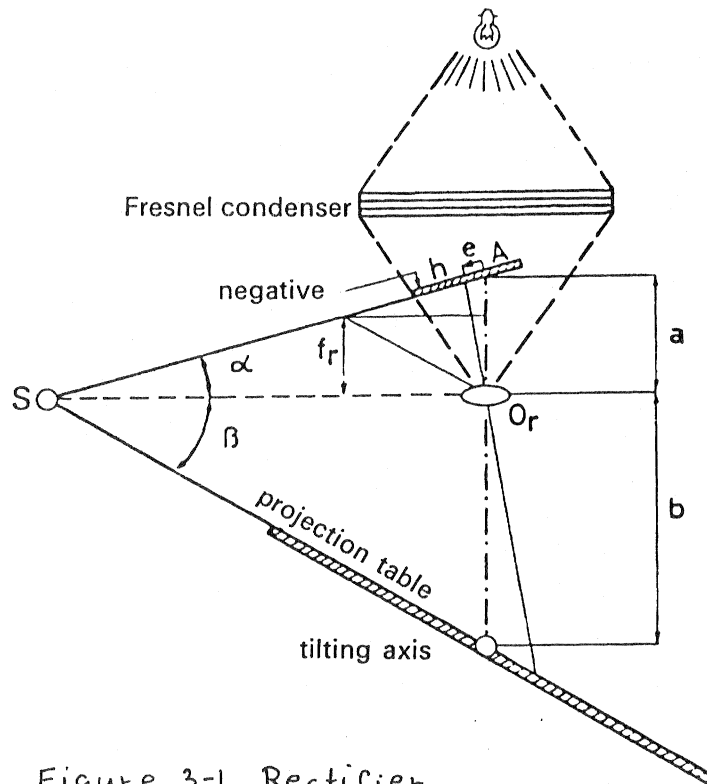

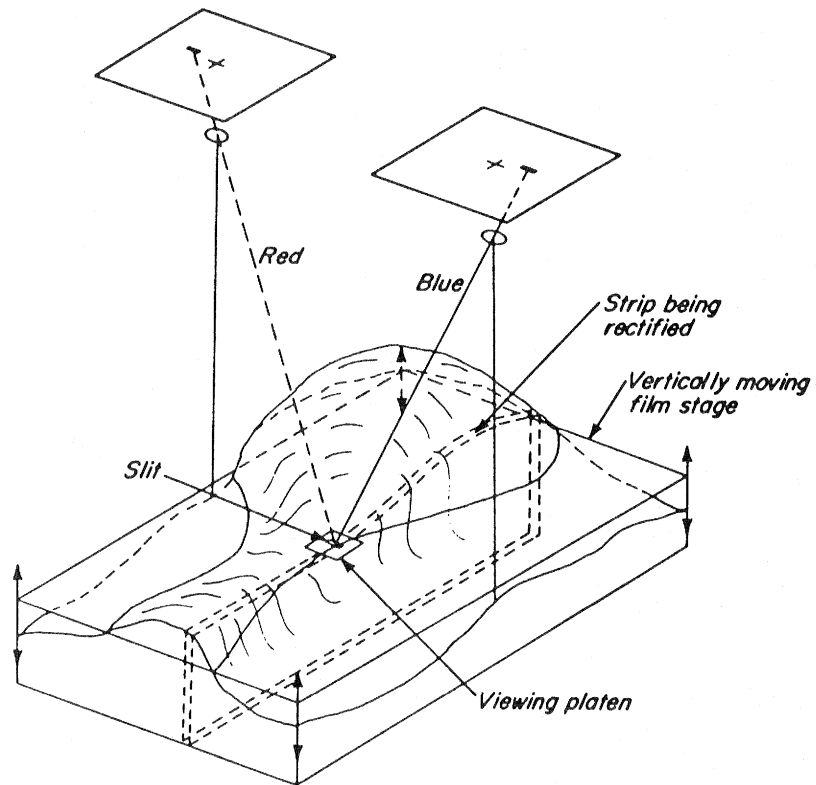

Fixed line element rectification.

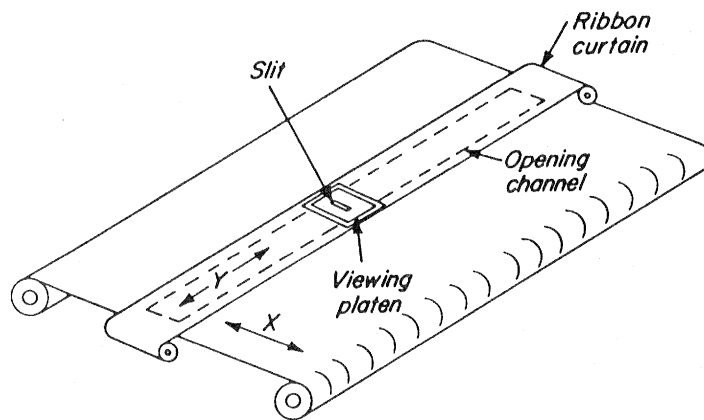

Curtain used to cover film exposure in line element rectification.

Figure 3-3 Differential rectification

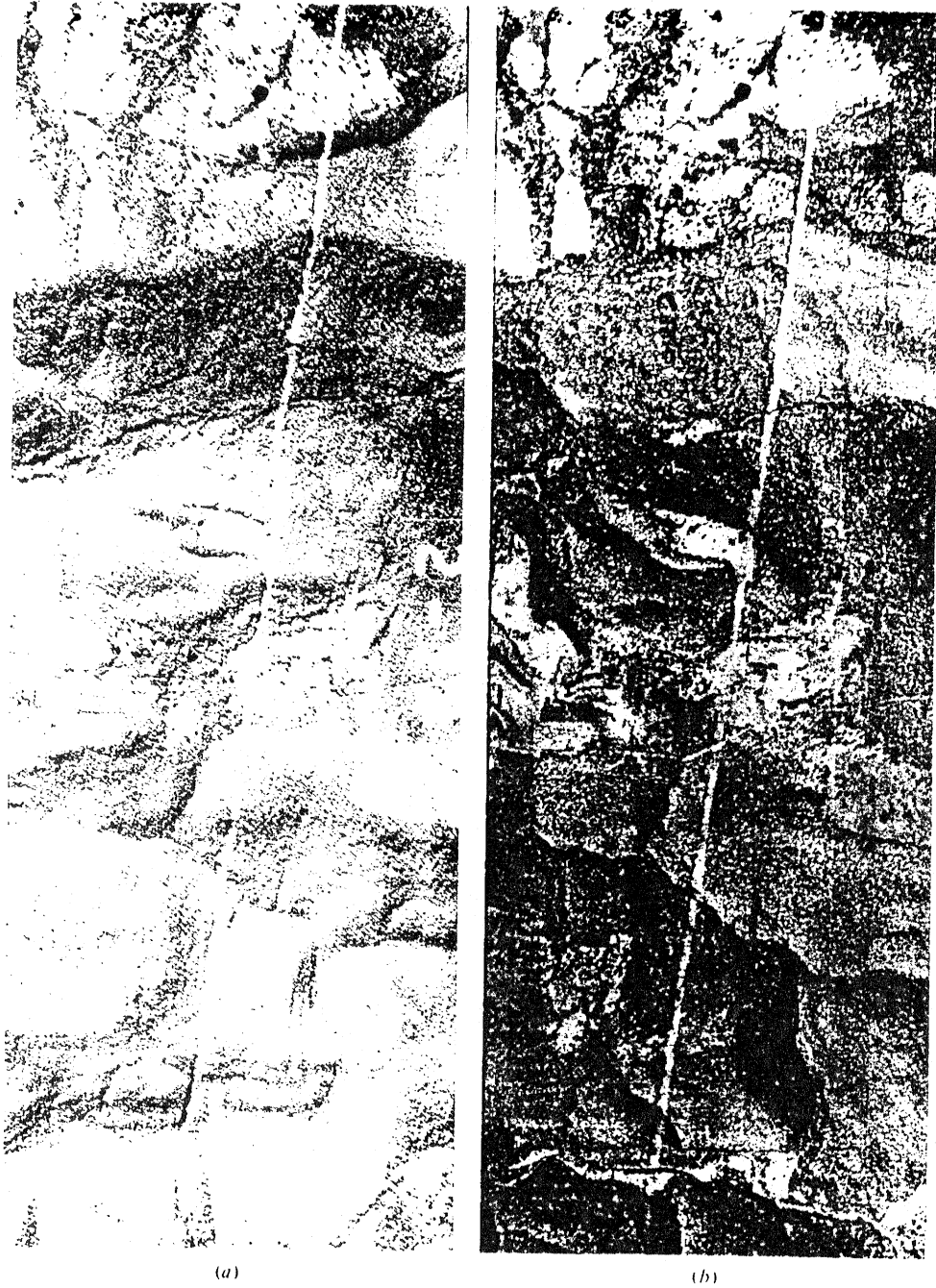

FIGURE 3-4.

(a) Portion of a perspective photo taken in Oklahoma. (Note the apparent crookedness of the power line caused by relief displacement.) (b) Orthophoto of same portion of perspective photo shown in (a). (Note straightness of the power line after relief displacement is eliminated.) (Courtesy U.S. Geological Survey)



*Robinson-Standard Aerial Surveys, Inc.*

Figure 3-5. Index mosaic. Orono and Old Town, Maine.



FIGURE 3-6.

A portion of an orthophotomosaic with elevation contours superimposed.  
(Courtesy USDA Soil Conservation Service)

## 4. STEREO PHOTOGRAMMETRY

### 4.1 Stereoscopic Viewing

From a single photograph one can only determine the relative position of points which lie in the same plane and therefore have a common scale. However, by viewing two photographs of the same object, and aided by stereoscopic vision, it becomes possible to determine all three dimensions.

Stereoscopic vision is the ability to perceive objects in all three dimensions. It is only possible by using both eyes simultaneously (binocular vision). It is true that one can judge distance with one eye (monocular vision), but this is done by comparing distances and is based on experience.

While viewing an object with both eyes, each eye sees this object from a slightly different angle and transmits a slightly different impulse to the brain, where a three-dimensional view is formed. This is natural or direct stereo vision.

When the eyes focus on a certain object, the optical axes of the two eyes converge on that object intersecting at an angle called the parallactic angle, ( $\phi$  in Figure 4-1). A distance parallel to the base, subtended by the parallactic angle is called the parallax ( $p$  in Figure 4-1). The magnitude of the parallactic angle and of the parallax bears an inverse relationship to the distance between an object viewed and the observer. The closer the object is to the observer the larger the parallactic angle and the parallax becomes.

Indirect stereoscopic vision occurs when photographs of an object taken from two different stations are viewed (Figures 4-1 and 4-2). The conditions for such stereoscopic vision are the following:

1. Both photography must be viewed simultaneously.
2. Each eye must view only one of the photographs.
3. The photographs must be aligned so that the extension of viewing rays associated with corresponding image points will intersect in space.

There are no problems with satisfying the first condition. Condition 2 is, however, difficult to satisfy since the two photos must be viewed with nearly parallel eye axes and, at the same time, the eyes must focus at a short distance. Fortunately, there are several instrumental aids available, such as:

- pocket stereoscope,
- mirror stereoscope (Figure 4-3),
- anaglyph viewing system (Figure 4-4),
- polonization filters,
- stereo-image alternator (Figure 4-5).

To satisfy condition 3, photographs must be arranged in the following way for viewing under a stereoscope (Figure 4-6):

1. Locate the principal point of each photograph.
2. Mutually transfer the principal points onto the two photos to establish the conjugate principal points.
3. Separate the two photographs at a distance which corresponds to the base of the stereoscope.
4. Rotate the photographs around their respective principal points until the lines joining the two pairs of principal points fall along a continuous line representing the flight line axis. The base of the stereoscope should be parallel to this line during viewing.



Photographs must be viewed in the same sequence as they were taken. If the left-hand and right-hand photos are interchanged, then an inverted view, called pseudoscopic view, will occur. Thus, depressions appear as ridges and peaks as depressions. For the same reason, photos should be viewed with shadows pointing towards or to the right of the observer.

For photogrammetric work aerial photographs are usually taken with 60% forward overlap between subsequent exposures. This assures a continuous stereoscopic coverage and allows the transfer of data from one stereomodel to the next. If more than one flight line is needed to cover the area of interest, a 20% to 30% side lap is maintained between strips (Figure 4-7).

#### 4.2 Parallax Measurement

Parallaxes of points in a stereopair may be measured either monoscopically or stereoscopically.

The simplest monoscopic method is to measure the  $x$  and  $x'$  coordinates of corresponding points on the left and right photographs respectively (Figure 4-8). Parallax is then computed as

$$p = x - x' .$$

Another monoscopic method is to measure the distance  $D$  between the principal point of the two photographs and the distance  $d$  between corresponding image points (Figure 4-8). The parallax becomes

$$p = D - d .$$

The stereoscopic method of parallax measurement requires the use of a floating mark or measuring mark. It consists of two identical marks (dot or cross) which are superimposed on the photographs. These marks, when viewed stereoscopically, will fuse into one single mark which appears

floating in space. If the separation between the marks is changed, the parallax of the marks will also change and the fused mark will appear to move up or down (Figure 4-9).

A simple device available for the stereoscopic measurement of parallaxes is the parallax bar. It consists of a metal bar to which two transparent platens with the identical marks engraved are fastened. The right hand mark may be moved with respect to the left mark by turning a micrometer screw and the fused floating mark can be set on a point whose parallax is desired (Figure 4-10).

For determining elevation differences between points or heights of objects it is sufficient to know the value of the parallax difference. This is simply the difference between readings from the micrometer when the floating mark is set on the two points.

$$\Delta p = p_1 - p_2 = r_1 - r_2$$

where  $r_1$  and  $r_2$  are readings on the micrometer (parallax bar).

The elevation difference is computed from the following equation (Figure 4-11):

$$\Delta h = \frac{\Delta p H}{b + \Delta p},$$

where  $\Delta h$  is the elevation difference between two points whose parallax difference is  $\Delta p$ ;  $H$  is the average flying height and  $b$  is the photo base. The value of  $b$  can be obtained by measuring the distance between the principal and the conjugate principal points.

The accuracy of elevation differences determined with a parallax bar is about 0.1% to 0.5% of the flying height. This accuracy is far below that what can be attained with precision photogrammetric instruments.

Nevertheless, this method can be used successfully for getting quick estimates for the height of structures, rock faces, trees, etc., for preliminary planning. Reasons for the low accuracy are the effect of tilt, uncertainty in the value of H and measuring errors.

#### 4.3 Stereoscopic Plotting Instruments

Stereoscopic plotting instruments (commonly called stereoplotters or simply plotters), are instruments designed to provide analogue solution for object point positions from their corresponding image positions on overlapping pairs of photographs. The basic concept underlying the design of these instruments is as follows (Figure 4-12):

The aerial camera is represented by a pair of projection systems (optical or mechanical) into which transparent positive images, called diapositives are placed. The interior orientation of the projection system must correspond to the interior orientation of the camera, so that the congruency of the projective rays is maintained. By two processes called relative orientation and absolute orientation, the same exterior orientation is established for both projection systems as the aerial cameras had at the time of exposure. The position and elevation on the ground (X,Y,Z coordinates) of at least three points must be known for this purpose. These points, called ground control points, must be positively identifiable on the photographs.

By the orientation process a stereomodel is created which is an exact replica, at a known scale, of the terrain photographed. Furthermore, this model is referenced in position and elevation to the ground (survey) coordinate system.

A viewing system, based on the principle described in Section 4.1 makes this model visible to an operator. A floating mark, measuring scales and a drafting mechanism enables the determination of X, Y, and Z ground coordinates of points and the tracing of planimetric details and contour lines (Figures 4-13, 4-14).

#### 4.4 Aerial Triangulation

It was stated in the previous section that several ground control points are needed to orient a stereomodel. The amount of field work required for obtaining this data can be reduced considerably by aerial triangulation. This procedure involves joining stereomodels together photogrammetrically to form a strip or block of model, which can then be oriented to the ground as a unit. Ground control, measured by field survey, is only required at five to ten model intervals. Ground coordinates of intermediate, additional points can be determined from photogrammetric measurements (Figure 4-15).

#### 4.5 Analytical Methods

The term analytical is used to denote procedures carried out by computation rather than by instrumental (analogue) methods. All photogrammetric procedures can be performed in this way. The only measurements required are the coordinates on the photographs of the points of interest. This can be done in a mono- or stereo-comparator with high accuracy, usually to 1 or 2  $\mu\text{m}$ . The use of a stereo-comparator aids the identification of points. Photo coordinate from two photographs are then used to compute the relative and absolute orientation parameters and the ground coordinates of all measured points.

The main advantage of analytical methods is that they are more accurate than analogue methods and faster in terms of instrument time. Therefore, analytical methods are particularly suitable for the determination of ground coordinates of individual points in aerial triangulation, cadastral surveying, deformation measurements, etc. For mapping, however, analogue methods are more economical to use.

Semi-analytical methods are also in use whereby a stereoscopic model is set up in a stereoplotter by relative orientation and then model coordinates are measured. Absolute orientation and the determination of ground coordinates are done by computation.

#### 4.6 Analytical Stereoplotters

An analytical stereoplotter is basically a stereocomparator with an on-line digital computer and a plotting table attachment. Photo coordinates are measured as in the analytical method discussed in the previous section. The measurements are automatically picked up by encoders and are entered into the computer. Various constants such as principal distance, scale, coordinates of ground control points are also stored in the computer. Here, the orientation is performed numerically and a mathematical stereomodel is formed. Ground coordinates can then be obtained in real time for any point where photo coordinates are measured or a graphical output (map) can be produced at any scale on the plotting table. The floating mark and the plotting pencil can be driven by the computer in any direction via servo motors. Thus, certain operations, like measurement of profiles or cross sections, can be performed in a semi-automated mode.

#### 4.7 Digital Methods

The term digital is used in photogrammetry to denote that information is collected and stored in a digital rather than a graphical form. In surveying terms this means, that the terrain is represented by a dense raster of X, Y, Z coordinates. Each point represents the planimetric position and elevation of a small surface element. Such a data set is called digital terrain model (DTM) or digital elevation model (DEM) (Figure 4-16). Contour lines can be represented digitally by giving the X and Y coordinates of the lines in small increments. Planimetric features (road, buildings) or natural and legal boundaries can be defined by the X, Y coordinates of their break points.

Photogrammetry is very suitable for collecting terrain information in this form. With the help of encoders attached to the movements of stereoplotters X, Y, Z coordinates can be automatically picked up along the path of the floating mark in the stereo model and stored on magnetic tape or disk. After editing the data is stored in digital data banks.

Digital data can easily be manipulated to obtain information such as distances, areas, volumes, feature counts. It can be sorted into feature classes, aggregated, merged or overlaid with information from various sources.

A graphical presentation of digital information can be produced on automated plotting tables which operate under computer control (automated cartography) or a quick look can be obtained on a graphic terminal.

#### 4.8 Terrestrial and Close-Range Photogrammetry

Terrestrial photogrammetry deals with photographs taken with a camera located on the surface of the earth. The term "close-range

photogrammetry" has been adopted for the case when object distances are up to about 100 metres. Unlike aerial photography, with terrestrial photography the cameras are usually accessible and stationary, so that the position and elevation of the exposure station and the angular orientation of the camera (exterior orientation) can be determined.

The two types of cameras used here are the phototheodolite and the stereometric camera.

A phototheodolite is the combination of a camera and a theodolite. It is generally mounted on a tripod and can be centered over a station mark. The theodolite part is used to determine the direction of the optical axis of the camera and for performing field survey operations as required.

A stereometric camera consists of two identical metric cameras mounted rigidly at the end of a fixed base, with parallel optical axes. The shutter of both cameras is released simultaneously.

The determination of ground coordinates is simple from terrestrial photographs because the exterior orientation is known. Based on Figure 4-17, the X, Y and Z coordinates of point N are

$$Y = \frac{Bf}{p}, \quad X = \frac{Bx}{p}, \quad Z = \frac{Bz}{p}$$

where B is the base; f is the principal distance; x, z are the image coordinates measured on the photographs and p is the parallax. The origin of the coordinate system is at the projection centre of the left camera, the Y axis points in the direction of the optical axis of the left camera which is perpendicular to the base and the X axis points in the direction of the base.

In addition to analytical methods, stereoscopic plotting instruments may also be used to determine the positions of object points from terrestrial photographs.



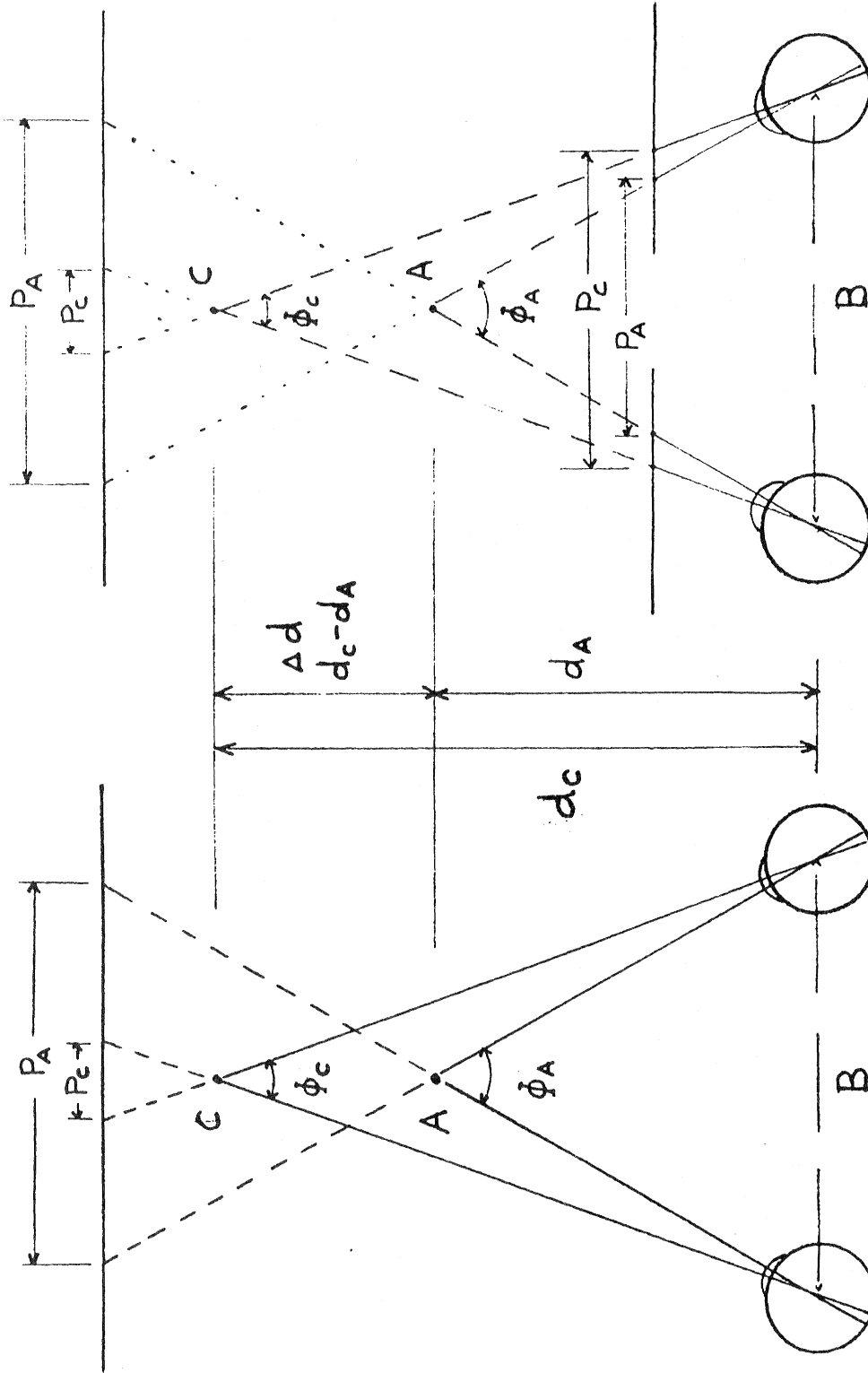

Direct Indirect  
Figure 4-1. Stereoscopic Vision

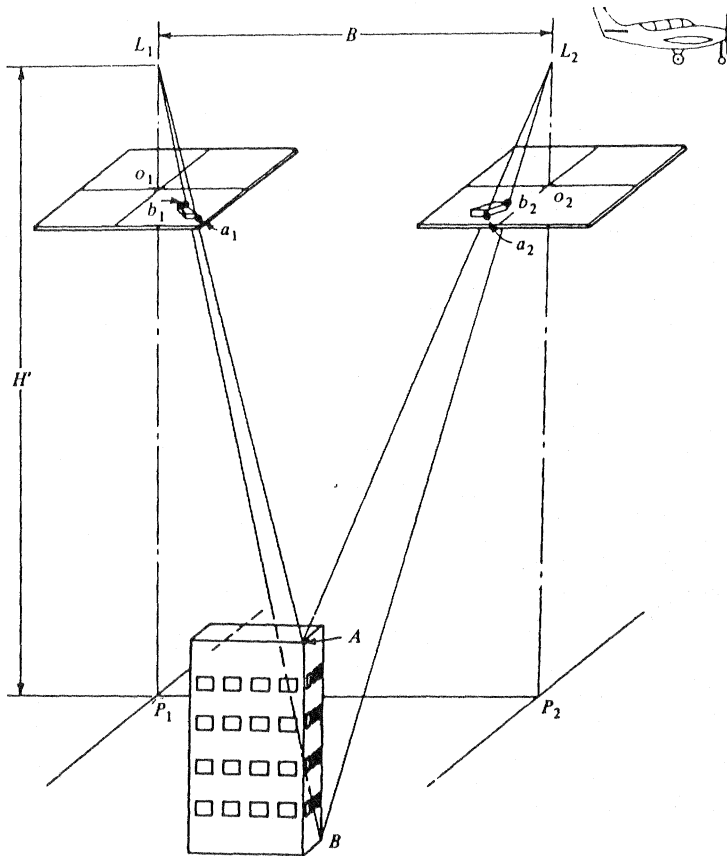

FIGURE 4-2 a  
Photographs from two exposure stations with building in common overlap area.

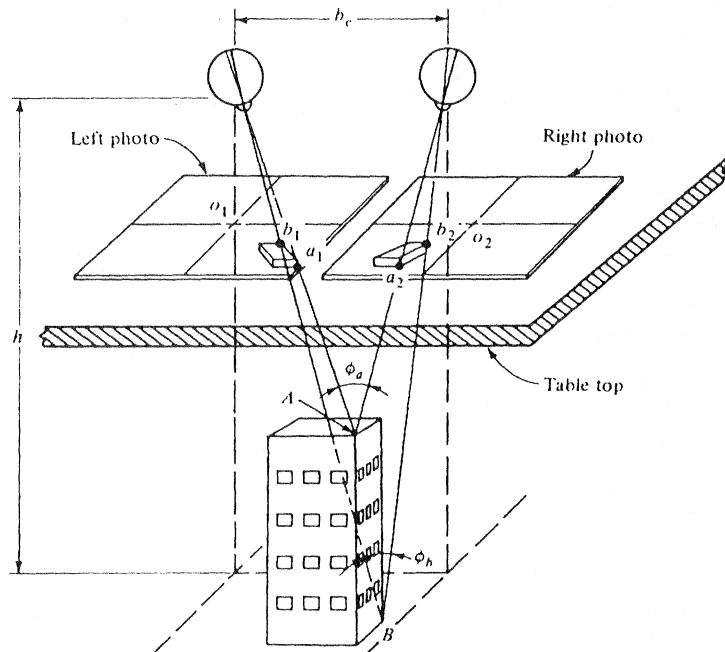

FIGURE 4-2 b  
Viewing the building stereoscopically.

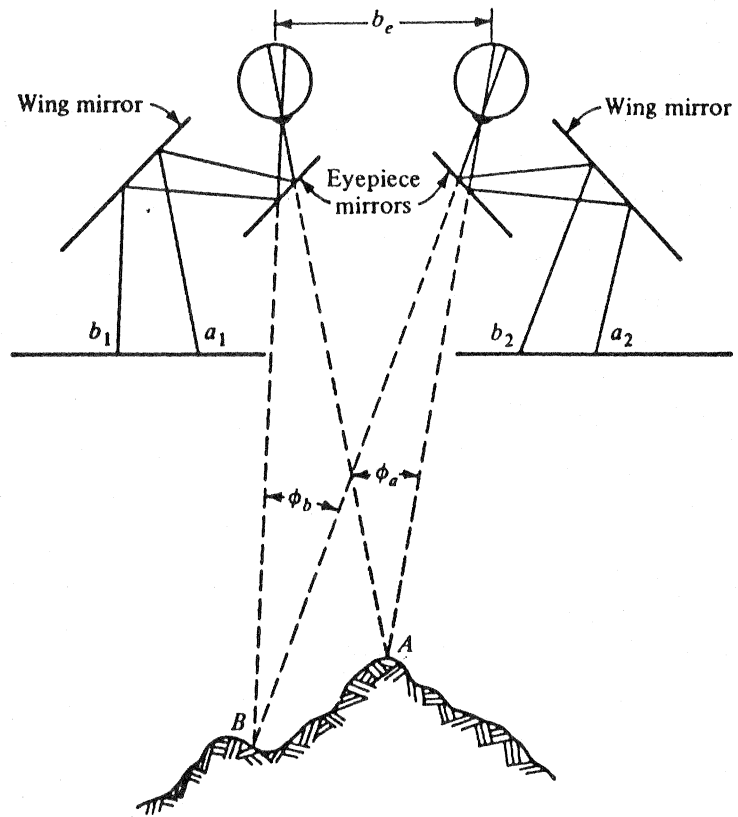

FIGURE 4-3.  
Operating principle of the mirror stereoscope.

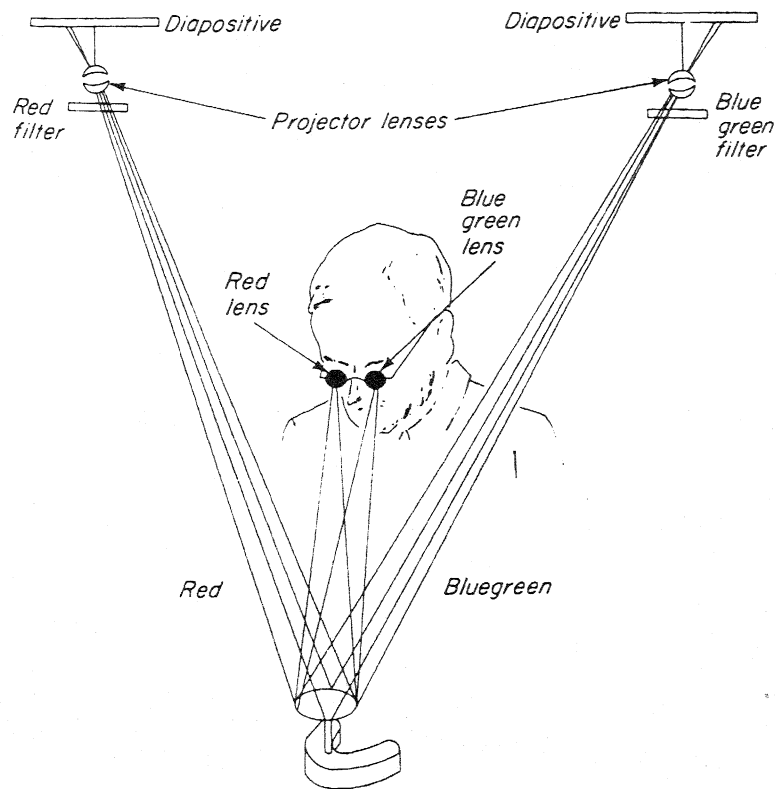

Figure 4-4. Anaglyphic viewing.

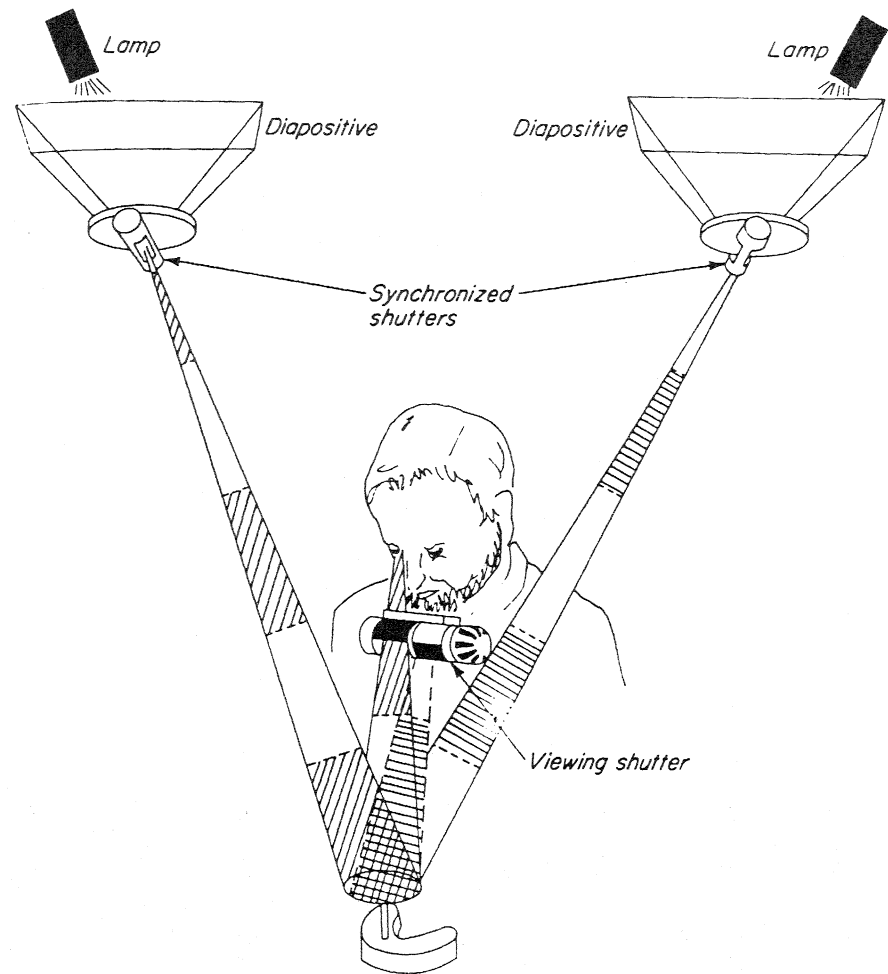
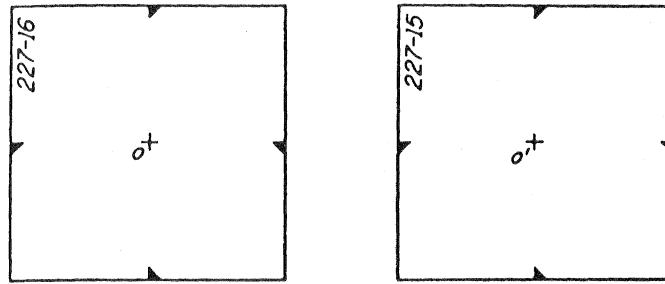
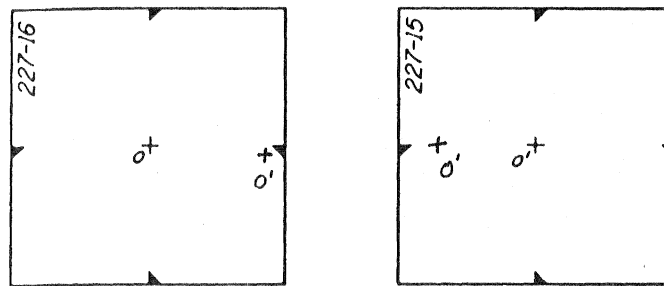

Figure 4-5. Principle of stereo image alternator (SIA).



(a)



(b)

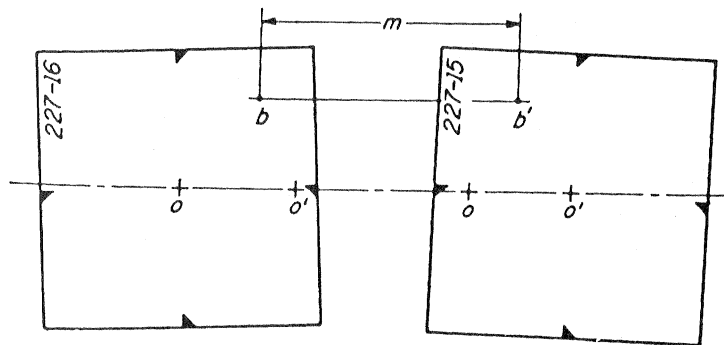

(c)

Figure 4-6. Orienting photographs for viewing under stereoscope.

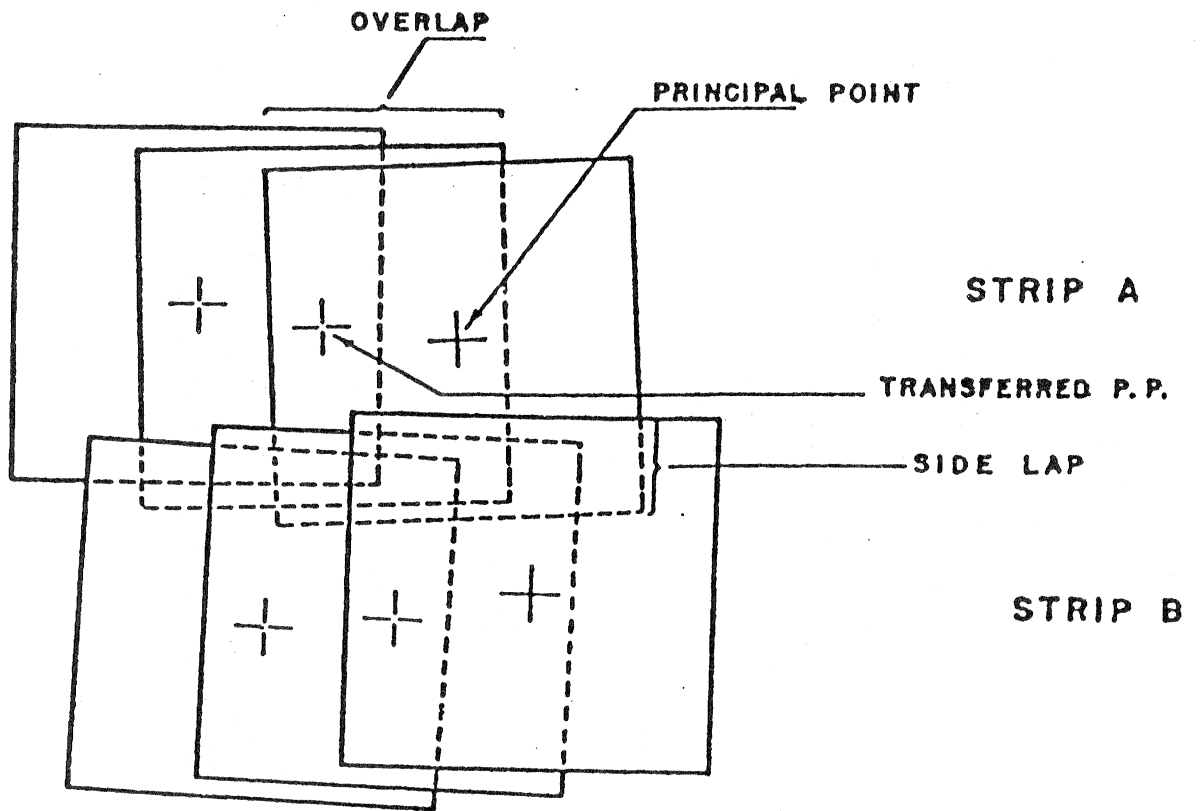
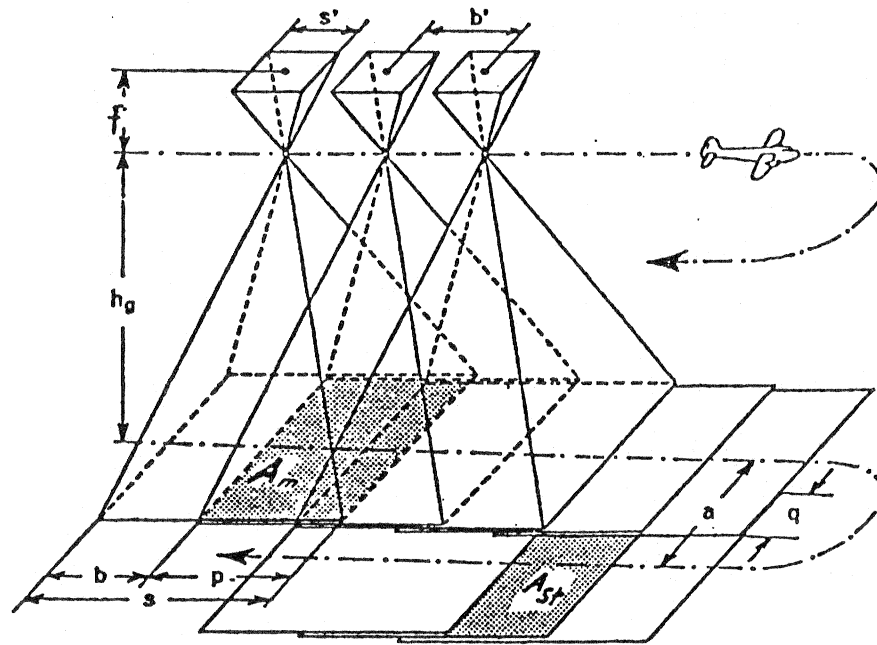

FIGURE 4-7. OVERLAP AND SIDE LAP OF AERIAL PHOTOGRAPHS

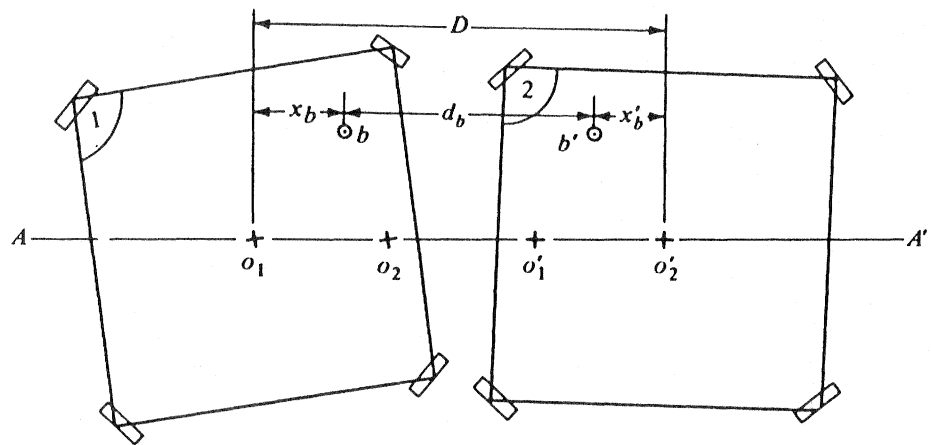

FIGURE 4-8.  
Parallax measurement using a simple scale.

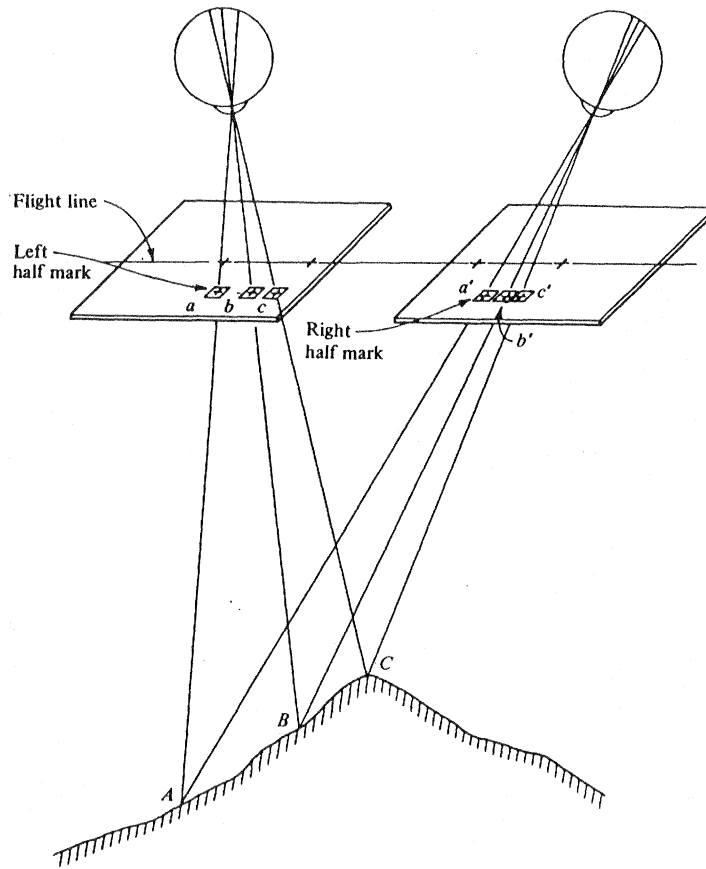

FIGURE 4-9.  
The principle of the floating mark.

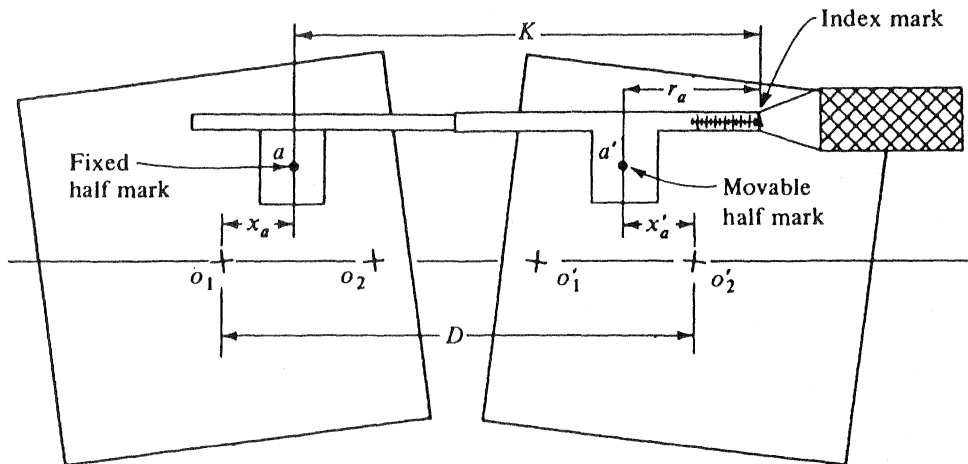

FIGURE 4-10.  
Schematic diagram of the parallax bar.



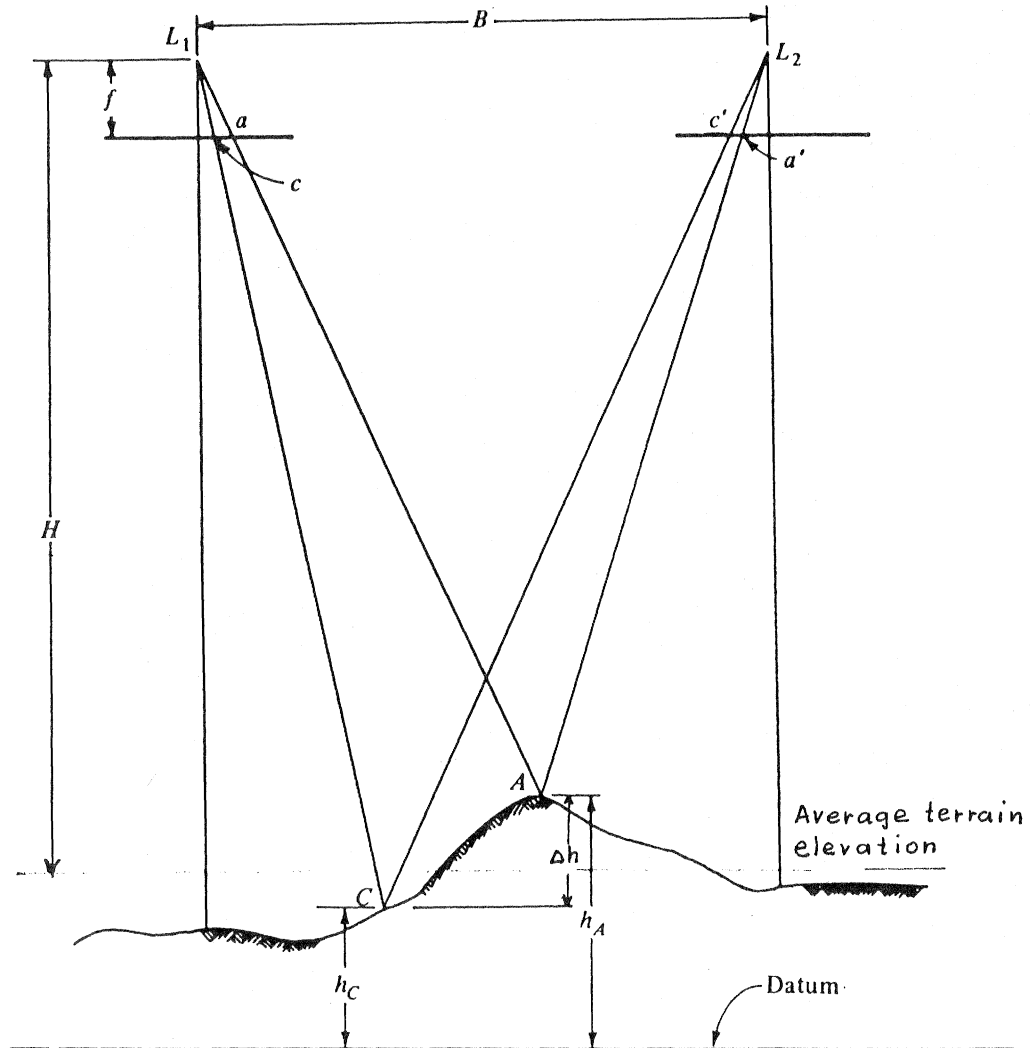
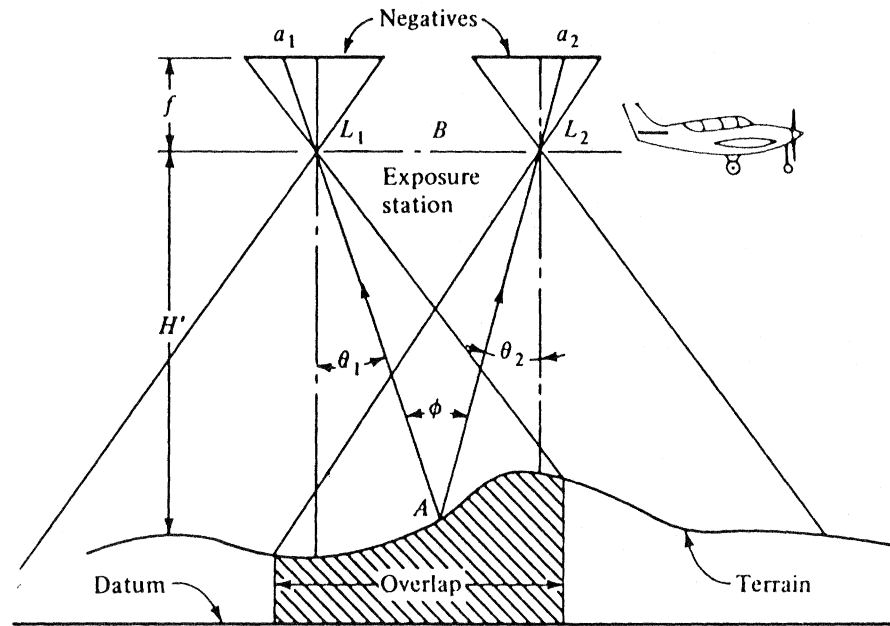
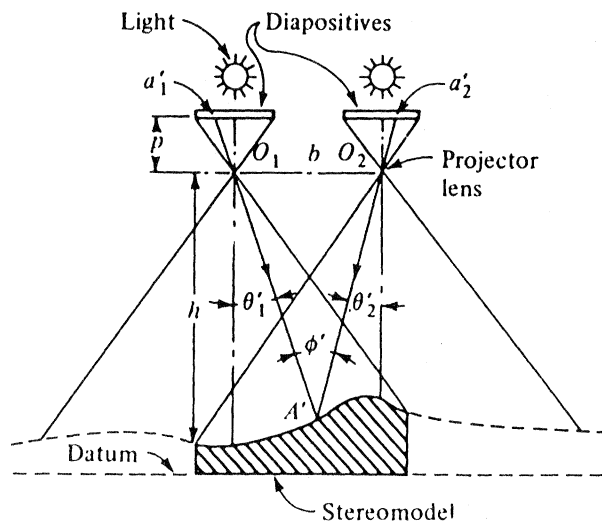

FIGURE 4-11.  
Elevations by parallax differences.



(a)



(b)

FIGURE 4-12.

Basic concept of stereoscopic plotting instrument design. (a) Aerial photography; (b) stereoscopic plotting instrument.

MULTIPLEX PLOTTER PROCEDURES

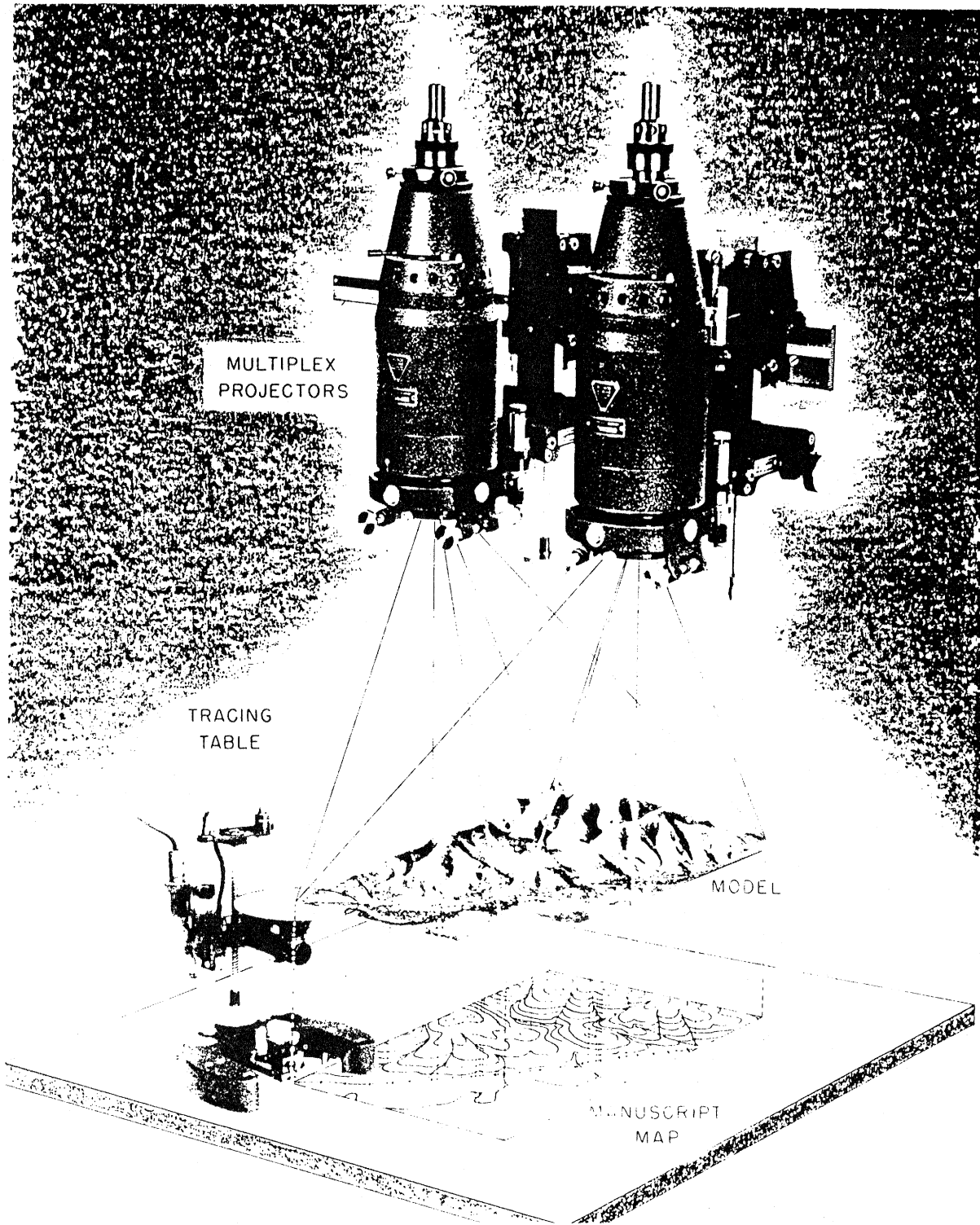

Figure 4-13. Principle of the multiplex.

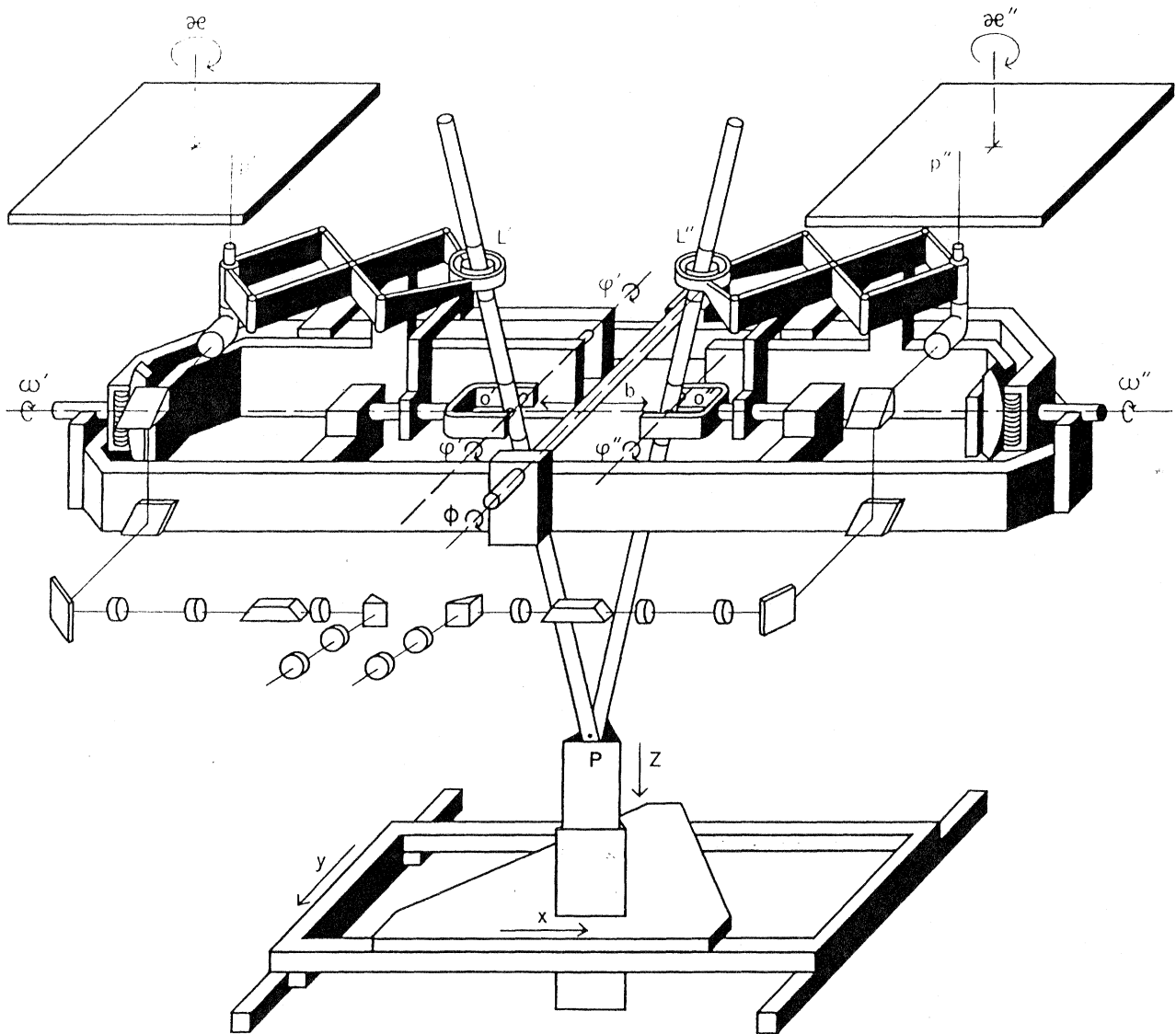
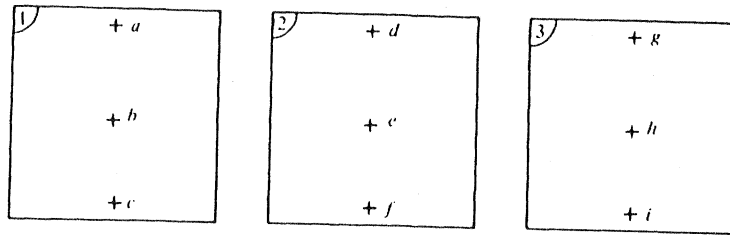
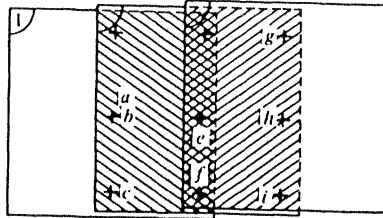

Figure 4-14

*Functional diagram of the Wild A8 Autograph*



(a)



(b)

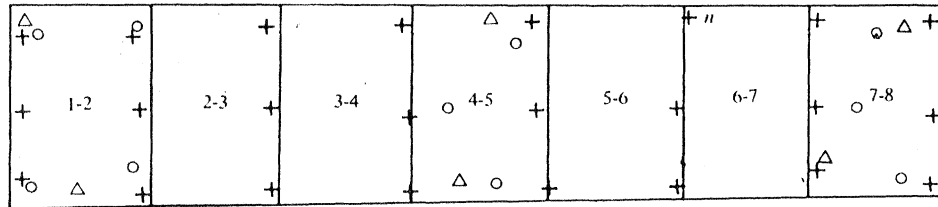

- △ Horizontal control point
- Vertical control point
- ⊕ Pass point

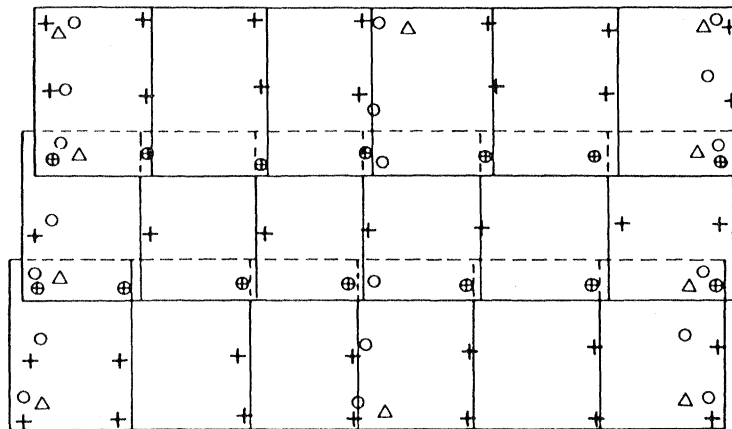

- △ Horizontal control points
- Vertical control points
- ⊕ Pass points
- ⊗ Tie points

FIGURE 4-15

Block of photos prepared for analytical control extension showing horizontal and vertical ground control points, pass points, and tie points.

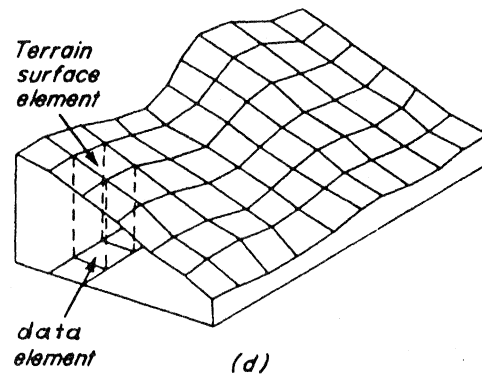
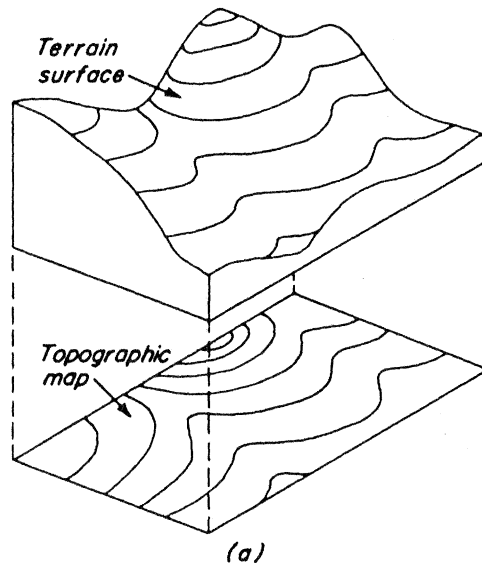
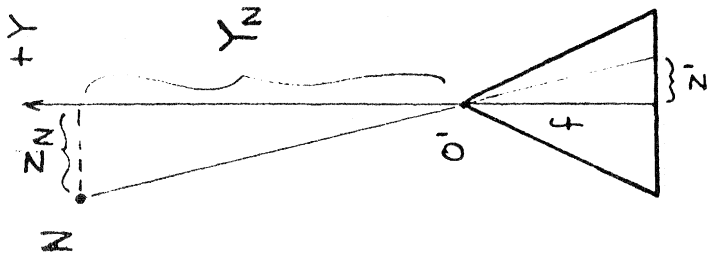

Figure 4-16. Digital terrain model



$$Y = \frac{B}{P} f$$

$$X = \frac{Y}{f} X' = \frac{B}{P} X'$$

$$Z = \frac{Y}{f} Z' = \frac{B}{P} Z'$$

$$Z = \frac{Y}{f} Z'' = \frac{B}{P} Z''$$

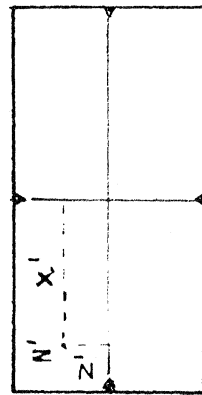
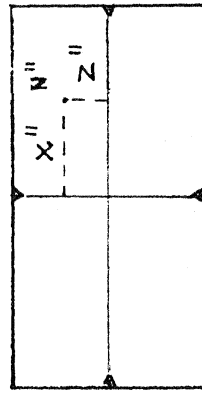
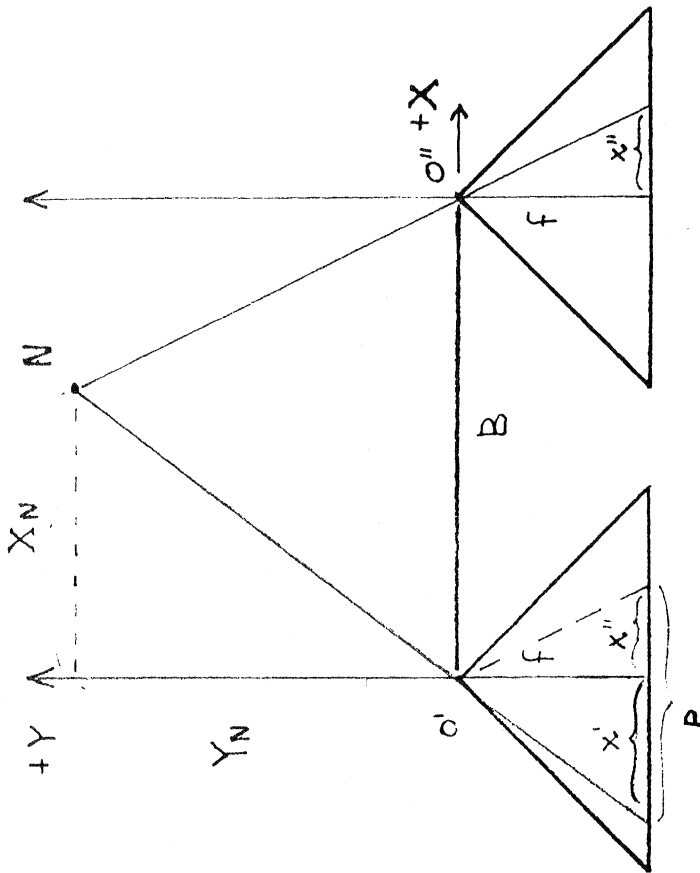

$$X' - X'' = p \quad X\text{-parallax}$$

Figure 4-17. Terrestrial Photogrammetry

Normal Case

or

## 5. PROJECT PLANNING

### 5.1 Photogrammetric Accuracy

There are three essential parts to any photogrammetric project:

- Acquisition of the data (photography),
- Ground control,
- Evolution of the data (measurements).

The quality of each element governs the quality of the end product.

Photographs for photogrammetric work must be taken with a metric camera using dimensionally stable film. The term metric camera means that it was manufactured specifically for photogrammetric use. It has fiducial marks built into the focal plane, the lens system has low distortion and it is completely calibrated to determine interior orientation. The photographs must be taken as laid down in the flight plan and must meet the requirements outlined in a set of standards and specifications.

The photographs are related to the ground by control points. The number and distribution of these points must be adequate for the project in question. Cost of establishing ground control may be, at time, quite high; taking shortcuts and being frugal with ground control to save cost, however, can easily lead to unsatisfactory outcome of the project. Existing control points must be thoroughly checked to assure their suitability.

Generally speaking the accuracy of photogrammetric measurements depends on the type of instruments used. Other factors include errors in the setting up of the stereomodel, the quality of the photography, the type of features measured, the skill of the operator. When maps are compiled, errors in the cartographic production process must also be considered.

Photogrammetric instruments can be classified as follows:



Table 5-1

Type	Reads to	Enlarges	C-factor
Comparator	0.001 - 0.005 mm	---	---
Analytical	0.001 - 0.005 mm	no limit	1500 - 2000
Precise	0.01 - 0.02 mm	8x	1200 - 1800
Topographic	0.02 - 0.05 mm	4x	800 - 1200
Approximate	0.05 - 0.1 mm	2x	100 - 800
Direct meas.	0.2 - 0.5 mm	1x	--

Enlarging means a change of scale from photograph to map manuscript.

The actual measuring accuracy is lower than the values listed in Table 5-1, sometimes by a factor of two, because of the other influences mentioned earlier. These accuracy figures can easily be translated to values on the ground if the scale at the photograph is known. Furthermore, these figures are valid for point-by-point measurements. For measurements in stream mode (plotting, contouring) a lower accuracy is expected. The map accuracy standards, discussed in section 5.3 give good indications of what to expect.

## 5.2 Flight Planning

The project boundary, the scale of the photography, forward overlap and side lap in percent, the type of camera to be used and special requirements if any must be specified for every photogrammetric project.

It was mentioned in the previous section that accuracy, as defined on the ground, is interrelated with the scale of the photograph and the type of measuring instrument used. The latter also controls the maximum range of scale change from photograph to map.

A good estimate for the required photo scale can be obtained from the empirical formula

$$S_p = K\sqrt{S_m},$$

where  $S_p$  is the scale factor of the photograph;  $S_m$  is the scale factor of the map and  $K$  is a constant ranging from 150 to 300. The lower value is for very large scale mapping, i.e., 1:500 and the high value is for small scales, i.e., 1:50 000 or 1:100 000.

Another empirical formula defines the relationship between contour interval and flying height. Whereby

$$C = \frac{H}{\Delta h},$$

where  $H$  is the flying height above terrain;  $\Delta h$  is the contour interval and  $C$  is a constant referred to as C-factor. It ranges in value from 100 to 2000 depending on the instrument used (see Table 5-1). Knowing the flying height, the photo scale can be computed.

The project boundaries and the flight lines are shown on a flight map with other pertinent information and passed on to the navigator and/or the pilot.

### 5.3 Standards and Specification

All engineering projects must be carried out according to specifications and must meet certain standards. Surveying projects are no exception. As an example the standards and specifications of an actual mapping project at a scale of 1:2000 is given at the end of this chapter. The exhibits referred to are omitted.

The sub-section headings indicate items on which the agency or company executing the mapping project must be informed. Details under these headings express the requirements of the client. The standards are set under the heading Map Accuracy. The statements made here are widely used in Canada and indicate the accuracy of good quality maps in general.

Detailed specifications of this type must be prepared for all phases of a photogrammetric project, such as for the establishment of ground control, aerial photography, aerial triangulation.

#### Words of Caution

- Do not borrow or adopt the specifications of others, unless you are certain that they completely satisfy your needs.
- Do not attempt to prepare photogrammetric standards and specifications unless you are an expert in photogrammetry.
- Be clear about the information and standards required for the engineering project for which the survey is needed.
- Be specific if you state tolerances for surveying and mapping data such as position, elevation, distance, direction. Never say "as accurately as possible".

Remember over-design means unnecessary expense, under-design may mean disaster.

- CONTACT AND EXPERT to discuss your requirements.
- make sure that upon completion of a surveying and mapping project, all the data and/or products generated inspected by an independent expert.

#### 5.4 Classification of Maps

Maps can be classified in various ways:

- (a) According to the way the terrain is depicted:
  - Planimetric maps, which only shows the position of features;
  - Topographic maps, which shows contours and spot heights.
- (b) According to cartographic properties:
  - Line drawn maps;
  - Photo maps.
- (c) According to colour:
  - Monochrome (black and white);
  - Multicolour.
- (d) According to the production method employed:
  - Original compilation, which is produced from data acquired specifically for making the map in question.
  - Derived maps, which are made from existing maps by enlargement or reduction and/or adding and/or deleting information.
- (e) According to the use and purpose:
  - Basic maps, which are made for multipurpose use by a central mapping agency. These maps usually provide a systematic coverage of an administrative unit, e.g., country, province, municipality.
  - Project maps, which are prepared in support of a project, e.g., highway construction, exploration and mining.
  - Thematic maps, which are made to display a specific type of information, e.g., geology, forestry, soils, population distribution.
- (f) According to scale:
  - Small scale, 1:100 000 and smaller;
  - Medium scale, from 1:10 000 to 1:100 000;
  - Large scale, larger than 1:10 000.

The succession of map principal scales used for basic mapping in Canada is:

1:1 000 000  
1: 500 000  
1: 250 000  
1: 125 000  
1: 50 000  
1: 25 000  
1: 20 000  
1: 10 000  
1: 5 000  
1: 2 000  
1: 1 000  
1: 500

Scales from 1:25 000 to 1:1 000 000 belong to Canada's National Topographic System (NTS) and are produced by the Surveys and Mapping Branch, Energy, Mines and Resources Canada. These are multicolour topographic maps. The sheet lines are geographic latitudes and longitudes. The sheet numbering system is shown in Figures 5-1 and 5-2.

The 1:1 000 000 scale maps are produced as part of a world-wide project supervised by the United Nations.

The 1:500 000 scale maps are produced as base maps for aeronautical charts and cannot be accurately called topographic maps.

The 1:250 000 scale series is the largest scale at which all of Canada has been mapped topographically. The contour interval is 100 feet in flat and hilly areas and 500 feet in mountainous regions.

The 1:125 000 scale series was intended to cover those areas of Canada of interest to tourists, but production at this scale has now been suspended. The contour interval is 50 feet and the topography is enhanced by hill shading.

The 1:50 000 scale series is nearly complete for the entire country. Contour interval on the old editions is 50 feet or 100 feet depending on the topography. On the maps produced during the last ten years the contour intervals are 10 m or 20 m. Currently, there is a changeover in production from manual to digital techniques.

The 1:25 000 scale series covers only densely settled areas or specific sites of intense industrial activity. The contour interval is 10 feet. Production at this scale has been suspended.

Copies of all NTS sheets and further information about Canadian maps can be obtained from:

Map Distribution Office  
Energy, Mines and Resources Canada  
615 Booth Street  
Ottawa, Ontario

NTS maps covering New Brunswick can also be obtained from:

Lands Branch  
Department of Natural Resources  
Centennial Building - Room 576  
P.O. Box 6000  
Fredericton, N.B.  
E3B 5H1  
Telephone: (506) 453-2764

Aerial photographs, grant plans, fishing guides, crown land surveys covering the province are also available at this office.

Basic maps at scales from 1:5 000 to 1:20 000 are considered provincial series. The only systematic coverage available of New Brunswick is the 1:10 000 scale orthophoto map series with 5 m contours. It is produced by the Maritime Land Registration and Information Services (MLRIS). The production of a new 1:10 000 scale map series for the Maritimes will start in 1984 using digital techniques. These will be line maps with 5 m contours.

Basic maps at scales larger than 1:5 000 are considered urban maps. In New Brunswick all population centres are mapped at scales 1:1 000 or 1:2 000 with 1 m or 2 m contours.

Property boundary overlays are also available for the Maritime and the urban map series. All provincial maps can be obtained from the Lands Branch, DNR or from Regional Offices located in larger centres.

Please note that aerial photographs covering any part of Canada are available from:

National Air Photo Library

615 Booth Street

Ottawa, Ontario

K1A 0E4

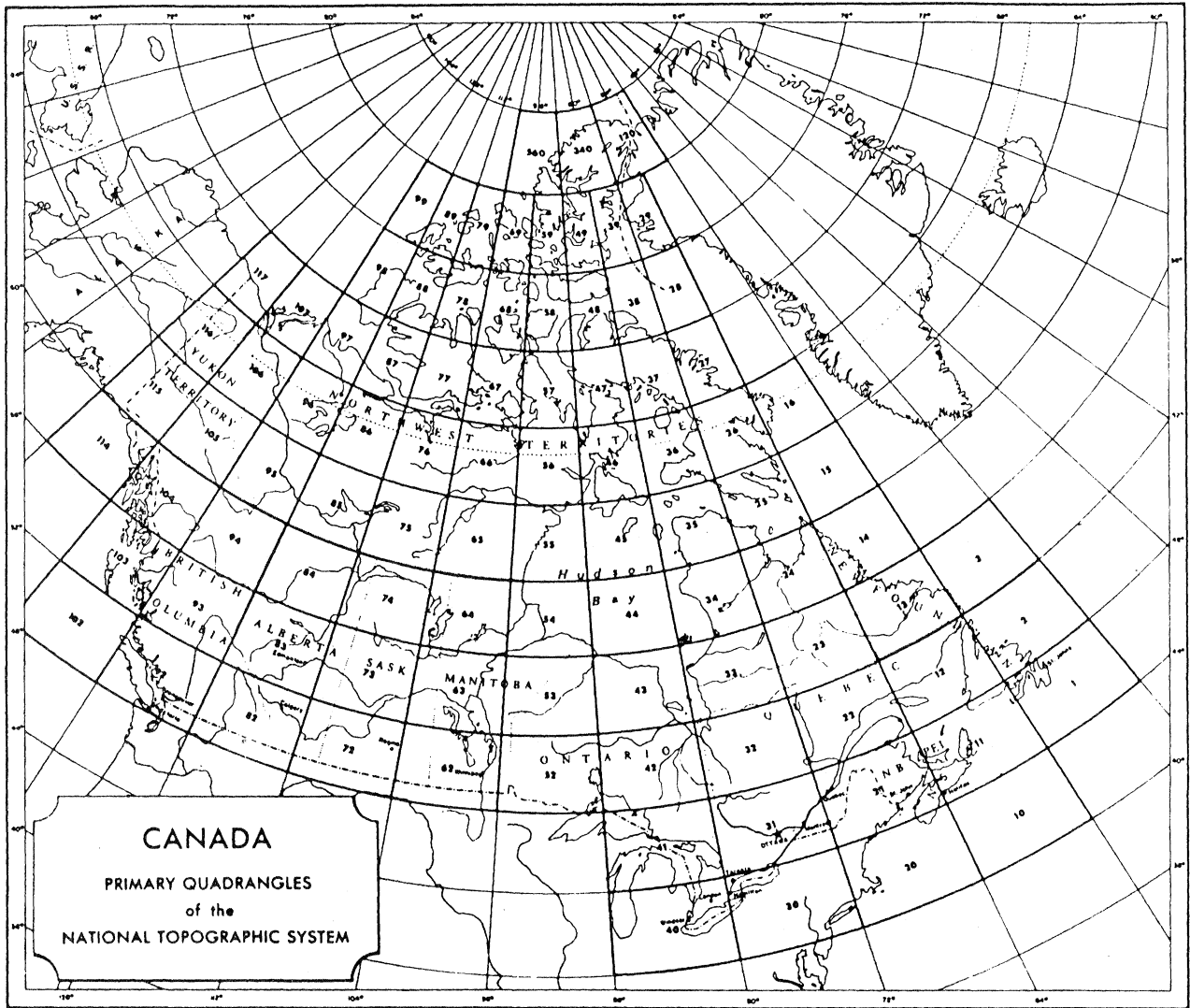

FIGURE 5-1. The primary quadrangles shown here are numbered and divided as shown in Figure 5-2.

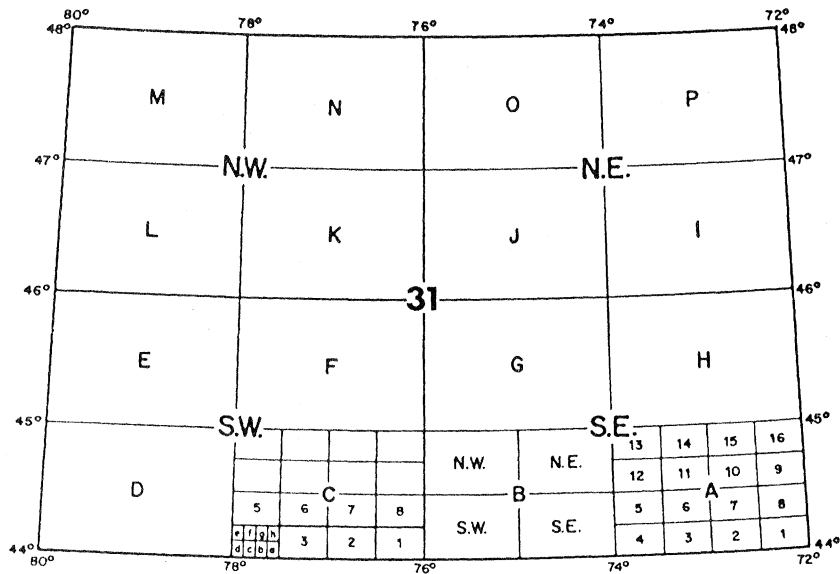

FIGURE 5-2.

The national Topographic System of Canada includes the following scales: 1:1,000,000, 1:500,000, 1:250,000, 1:125,000, 1:50,000 and 1:25,000. Canada is covered by primary quadrangles 4° north to south and 8° east to west (16° east to west, north of 80° north latitude).

Examples of the sheet numbering system are as follows:

- 31** A sheet of the 1:1,000,000 series, (the whole of the quadrangle illustrated on the left).
- 31 SW** A sheet of the 1:500,000 series, (one quarter of the quadrangle).
- 31 G** A sheet of the 1:250,000 series, (one sixteenth of the quadrangle).
- 31 B/NE** A sheet of the 1:125,000 series, (one quarter of a 1:250,000 sheet).
- 31 A/8** A sheet of the 1:50,000 series, (one sixteenth of a 1:250,000 sheet).
- 31 C/4a** A sheet of the 1:25,000 series, (one eighth of a 1:50,000 sheet).



SPECIFICATIONS  
FOR  
BASIC MAPPING  
IN THE  
PROVINCE OF ONTARIO

Prepared by  
SURVEYS AND MAPPING BRANCH  
ONTARIO MINISTRY OF NATURAL RESOURCES  
July, 1976

SECTION 3c: 1:2000 SCALE MAPPING3.01 Scope of the Specifications

The specifications hereinafter detailed define the standards which are to apply to the photogrammetric compilation and to the preparation of the reproduction artwork of topographic maps at a scale of 1:2000.

The specifications are based on the "Canadian Association of Aerial Surveyors, General Specifications for Topographic Mapping at the Scale of One Inch Equals Two Hundred Feet" dated September, 1963 and hereafter referred to as "C.A.A.S. Specifications". Certain items have been added, modified or deleted as deemed appropriate.

3.02 Equipment

The method of compilation and the type of instruments employed shall be at the discretion of the Contractor but must be to a standard which insures the quality and accuracy of the final map as specified hereunder.

3.03 Projection System

All maps shall be compiled using rectangular coordinate values expressed in metres and based on the 6<sup>0</sup> Universal Transverse Mercator system.

3.04 Vertical Datum

The vertical datum to be used in the mapping shall be mean sea-level as established by the Geodetic Survey of Canada and will be shown in metres.

3.05 Language

All information shown on the maps shall be in English.

3.06 Sheet Format

The sheet layout, general format and information shown on the surround shall be in conformity with samples supplied. Note that the sheet neatlines coincide with grid lines with values in integral multiples of 1000 metres and that the grid is displayed in integral values of 100 metres.

3.07 Border Annotation

Grid numbers, graticule ticks of the geographical coordinates at intervals of ten seconds, graticule figures, boundaries and names, shall be shown between neatline and border, as per sample supplied (Exhibit "E"). Full grid numbers will be shown at the four corners. Scale factor and sheet number shall be positioned on the north edge as per sample on Exhibit "E". Sheet index number, scale bar and other information shall be shown and positioned on the south edge as per sample on Exhibit "E". Each sheet index number will be in conformity with the details supplied on Exhibit "F".

3.08 Style and Drafting Requirements

Line gauge and symbology on the final manuscripts shall be in conformity with Exhibit "D" except where modified according to the Contractor's or other sample and previously approved by the Crown. Symbols which were not specified shall be selected by the Contractor and approved by the Crown. The elevation figure shall be positioned to the northeast of the spot height location wherever possible.

### 3.09 Nomenclature

Communities, streets, highways, railways, national and provincial parks, significant water features and islands shall be named. All names shall be shown as used by local administrative authorities. A limited number of additional names may be requested by the Crown.

### 3.10 Map Relief

#### a) Contours

Relief shall be shown by contours at one metre intervals. Whenever the contour lines are spaced 2.5 centimetres or more apart, 0.5 metre machine interpolated contours shall be shown. The term "relief" includes all those features necessary to portray the configuration and difference in height of the land surface included on the map. In addition to the accuracies specified, the contours shall be drawn so as to portray correctly the character of the terrain. The turning points of contours that define drainage channels shall be consistent in depicting the correct alignment of the channel and in reflecting the continuation of the drainage.

Depression contours shall be symbolized.

Every contour shall be drawn with the same line gauge. Index contours shall not be differentiated unless specifically requested by the Crown.

Contour values should read "uphill".

Where the ground is obscured by vegetation to the degree that standard accuracy is not obtainable, contours shall be shown by a broken line.

#### b) Spot Elevations

Spot elevations shall be shown where contours do not adequately express the character of the terrain. In addition they shall be shown:

- on intersections of roads, railways, trails, transmission lines, pipe lines and aerial tramways; where a definite change occurs in the alignment of those features and at intervals of one hundred metres along these features;
- at summits, knobs, depressions, along the rim and bottom of a gorge, gully and rock face;
- at or near major buildings along the rim of open pit mines, quarries and gravel pits and at the lowest point of these features; at the foot and top of log piles, sand piles, mine dumps, embankments and cuttings; and on bridges, large culverts, airport runways and landing strips;
- water levels on all named lakes, large ponds, below bridges, above and below dams.

Where the terrain is largely obscured by vegetation, spot elevations shall be read wherever the ground is visible to the extent that the reading can be obtained with confidence. In general, spot elevations shall be shown at a density equivalent to the sample on Exhibit "E". The Crown may indicate specific points on photographic prints where spot elevations are mandatory.

Spot elevations shall be shown to the closest 0.1 metre.

### 3.11 Map Detail

#### a) Buildings

The intention is to show buildings of a permanent or semi-permanent nature only. The following explanations will serve as a guide to assist the Contractor in interpreting the Crown's requirements, and to be used with discretion.

Buildings smaller than 20 square metres (one-car garage) shall be omitted. All other buildings shall be shown to shape and scale as determined by the outline of their roofs. Protrusions and indentations of 2 metres or smaller shall be generalized.

Where two or more building units are joined directly, the built-up area shall be outlined to shape and scale as a single unit and the dividing lines between the units shall be indicated within the outline.

Patios, paved areas, swimming pools, driveways, walkways situated on residential properties shall not be shown. Normally, steps are not shown, however, large sets of steps which are significant for proper representation of the topography, shall be shown.

Buildings under construction shall be shown as existing buildings if the construction advanced far enough that the size and shape can be anticipated, otherwise they should be omitted. Ruins of solid masonry or stone structures shall be outlined and symbolized. Derelicts of wooden frame structures shall be omitted.

#### b) Transportation and Communications

Roads, streets wide enough for vehicular traffic shall be shown to size and shape. The width of the roads will be defined either by the width from curb to curb, or the width of the travelled path. Sidewalks will not be shown.

Railways, overhead tramways, tracks, trails, footpaths transmission lines and above surface pipe lines of significance shall be shown by standard symbols representing the centre line of the alignment. Individual poles, towers or supports of these features shall not be shown. Service lines to individual buildings shall be omitted.

Each line shall be shown separately on cross-country multiple track lines. However, where a large number of these features occurs closely spaced such as in marshalling or switching yards, refinery areas, etc. only the outer two lines shall be shown and the area in between annotated.

#### c) Linear Features

Significant fences, walls, hedges and tree lines that are visible on the photography and in all cases those that appear to indicate a dividing line between adjacent properties shall be shown by a standard symbol. The above features shall not be shown if they appear ornamental in nature or form only a small enclosure. The above features shall also be omitted where they run parallel to roads and there is insufficient room on the map to display them clearly at their correct position. Guard rails, gates will not be shown.

d) Boundaries

International, provincial, territorial district, geographic township, indian reserve, national and provincial park boundaries will be shown. Current municipal or other local authority boundaries will not be shown.

e) Symbology (general)

Extensive diversification in symbology should be avoided in depicting cultural features.

- Enclosed structures such as oil and gas tanks, water towers, silos, etc.; open structures such as radio, radar, microwave and fire towers, etc; other features such as piers, docks, platforms, bridges, dams, etc. shall be outlined if they are large or long enough to be shown to scale. Airports and landing strips shall be outlined.
- Embankments, cuttings, dykes and retaining walls shall be shown by a standard symbol if they are long enough to be shown to size, but too steep to be shown clearly by contours.

f) Annotations

Annotations shall be in conformity with Exhibit "D". Annotations, as the composition of structures (wood, cement, etc.), classifications of buildings (post office, silo, greenhouse, etc.) and classification of land parcels (cemetery, park, orchard, etc.) shall be omitted except those specifically requested by the Crown.

g) Water Features

The intention is to show lakes, streams, falls, reservoirs and canals of significance. Streams averaging more than 4 metres wide shall be shown in double lines to size. Where course of a water feature cannot be definitely established, the approximate location shall be shown by a broken line so as to indicate the continuity of drainage. Where water flow direction is not obvious on any map sheet, appropriate flow arrows shall be inserted. Swamps will be portrayed by a standard symbol without outline. Ditches shall not be shown unless they indicate a major drainage feature.

h) Woodland

The intention is to differentiate forested or wooded land from lands cleared for other purposes and from naturally unforested land. Individual trees, clumps of trees, trees along hedgerows, bushes, etc. will not be outlined.

i) Mining and Geology

Mine shafts shall be shown to scale. Prominent rock outcrops; rock faces, open pit mines, quarries, gravel pits, mine dumps, sand piles, log piles, etc. that are of significance, shall be delineated and symbolized if they are too steep to be shown clearly by contours.

j) Control Points

All horizontal ground control falling within the mapping limits shall be plotted, numbered and symbolized, but the numbering shall be omitted from the reproduction artwork. All vertical ground control points shall be

plotted and the elevation shown to the closest 0.02 metre, numbered and symbolized but the point numbering shall be omitted from the reproduction artwork. All photogrammetric pass points falling within the mapping limits shall be plotted in their true position and symbolized.

### 3.12 Map Accuracy

- a) All basic information concerning the datum of the manuscript such as horizontal control points, projection and grid information, shall be located within 0.1 mm of its true position.
- b) Ninety percent of all well defined features with the exception of those unavoidably displaced by symbolization, shall be located within 0.5 mm of their true positions.
- c) Ninety percent of all contours shall be accurate within one half of the contour interval.
- d) Ninety percent of all spot elevations shall be accurate to within one quarter of the contour interval.
- e) Accuracies indicated under b) and c) relate to ground not sufficiently obscured by vegetation cover to cause significant error. In checking elevations taken from the manuscript, any vertical error may be decreased by assuming a horizontal displacement within the permissible tolerance.

### 3.13 Final Product

The Contractor shall scribe on separate punch registered foils the planimetry, contours and vegetation cover. Final product will consist of 0.007 inches of stable base clear film positives, emulsion down, suitable for lithographic reproduction.

### 3.14 Inspection

The compilation manuscript and reproduction artwork of the first two map sheets will be examined by the Crown to reassure the Contractor and to avoid misunderstanding.

### 3.15 Measurement for Payment

Measurement for payment will be on a "per map sheet" basis except that extra names and annotations shall be on a per diem basis. Sheets will be priced in four categories: centre core, urban, fringe and rural with the categories marked by the Contractor in advance on an index sheet. Broken sheets and sheets in a mixed category will be priced in proportion to ground area covered. Additional non-standard items shall be billed at a rate to be agreed prior to their execution.

## 6. APPLICATIONS OF PHOTOGRAMMETRY

Topographic mapping is the most common application of photogrammetry. Nearly all map compilation is now performed photogrammetrically. Besides map compilation, much of the ground control needed for photogrammetric work is also acquired by photogrammetric means.

Photogrammetry is a valuable tool in locating property corners and defining property boundaries.

Photogrammetry may be applied to many measuring problems in civil and other engineering and in non-engineering fields such as architecture, archeology, hydrology, medicine. Notable examples are:

- Measuring cross-sections and profiles for earthwork computations and for determining quantities in mining exploitation;
- Monitoring deformations and movements of large engineering structures such as dams, bridges, tall buildings;
- Monitoring surface subsidence in areas of underground excavation;
- Recording traffic and industrial accidents;
- Laboratory study of conditions of failure in structural elements;
- Mapping of flow patterns in hydraulic test flumes;
- Obtaining permanent records of historic sites and structures; Recording the conditions of these prior to reconstruction;
- Measuring the shape and size of models and prototypes in automobile, ship and aircraft industry;
- X-ray photogrammetry;
- Detection and measurement of deformities of the human body.

## GENERAL REFERENCES

- Moffitt, F.H. and E.M. Mikhail, 1980. Photogrammetry. Harper and Row, Inc.
- Wolf, P.R. 1983. Elements of Photogrammetry 2nd Edition. McGraw-Hill, Inc.
- Slama, C.C. (editor), 1980. Manual of Photogrammetry; 4<sup>th</sup> edition.  
American Society of Photogrammetry.



APPENDIX A

LABORATORY PROJECTS

Introduction to Photogrammetry

1. Familiarize yourself with aerial photographs. Look for the fiducial marks and examine the auxiliary information recorded along edge. Study the effect of relief displacement.
2. With the help of the flying height and the principal distance recorded on the edge determine the scale of the photographs, showing part of downtown Fredericton.
3. With the help of the control points (list attached) marked on a sample photo determine the scale of the other photos. What was the flying height if  $f = 152.3$  mm?
4. Determine the height of two buildings from the relief displacement.  
Procedure:
  - Establish the fiducial centre;
  - Measure the radial distance to the top of the building and the relief displacement;
  - Compute the height using the equation given in the notes.
5. Practice stereo viewing on the stereograms provided. Test your stereovision with a pocket stereoscope. A test pattern and answer sheet will be provided.
6. Arrange the two overlapping aerial photographs for stereo viewing under the mirror stereoscopes. Measure the x-parallax of the two buildings you have used in Item 4, with the parallax bar, compute the height of these buildings. Detailed instructions are attached.
7. Compare and analyze your results obtained for the height of the buildings using the two methods.
8. Prepare a short report. Outline the procedures followed, list the measurements made and results obtained and state your experiences.

All photographs and maps must be handed in at the end of the lab. Do not mark up the photos and maps in ink, use only soft pencil.

Coordinates of Control Points in Metres

Point	Easting (X)	Northing (Y)
1	92 526.828	459 810.146
2	92 903.046	461 304.635
3	94 330.516	460 700.107

### Height Determination Using the Parallax Bar

#### A. Orientation of the Photographs

- a) Place both photos in front of you, arranged in the proper sequence. The areas of common overlap must be side-by-side.
- b) Locate and mark the principal point in both photos (use the intersection of the lines joining opposite fiducial marks).
- c) Mutually transfer the principal points to form the conjugate principal points. (In the right photo, locate the feature which marks the principal point of the left picture, and mark it. Similarly, mark the principal point of the right photo in the left.) The line connecting the principal and the conjugate principal points is the photo base.
- d) Extend the line, connecting the principal and conjugate principal points, to the margins.
- e) Align the marks made on the margins with a straight edge. The centre of the two photographs should be about 250 mm apart. Secure the photographs to the table.
- f) Place the mirror stereoscope over the photograph.

#### B. Initial Setting of the Parallax Bar

Set the micrometer to a low reading (such as 5.0 mm) and place the parallax bar on the photographs parallel to the base. Loosen the thumbscrew of left measuring mark. Find the lowest terrain point, and place the right measuring mark over it in the right photo. With the right mark stationary, move the left mark over to the conjugate point in the left photo. Seen through the mirror stereoscope, the two marks should fuse into a single mark apparently floating in space above the terrain (floating mark). If two marks are seen, one above the other, one end of the parallax bar must be moved towards or away from the observer to align them properly. If they are seen side-by-side, slowly push the left mark towards the right until the floating marks fuse. Tighten the thumbscrew. The setting is retained throughout the measurements.

The floating mark is raised off the ground by turning the micrometer screw in the sense of increasing reading, and lowered by turning it in the opposite direction. Always set the floating mark on the ground by lowering it from above until it appears to touch the ground. If the mark appears to split, then it moved below the surface.

C. Parallax Measurements and Computation of Height Differences

The difference in height between the top and bottom of a building is computed from the equation:

$$\Delta h = \frac{\Delta p H}{b + \Delta p}$$

where: H is the average flying height,  $\Delta p$  is the difference in parallax measured at the top and bottom of the building and b is the photo base.

" $\Delta p$ " is determined by taking the difference in readings made on the parallax bar when the floating mark was set on the top and at the base of the building. Make at least 5 readings for each and take the average.

"b" is obtained by measuring the distance between the principal point and the conjugate principal point on both photographs and forming the mean.

Demonstration of PhotogrammetricInstruments

The following instruments will be demonstrated:

- Wild A10 Autograph (precision stereoplotter),
- Kern PG2 precision stereoplotter,
- OMI/PDP analytical plotter AP-2C,
- Zeiss PSK stereocomparator,
- Wild P30 phototheodolite,
- Wild C12 stereometric camera.

In addition, photogrammetric map production will be reviewed, based on the display panels in Room E-16.

Outline the principle of operation of each instrument in a short report.

Production of a Photomosaic  
and  
Reproduction of a Photomosaic

Purpose: The student should become familiar with the basic steps involved in producing a very simple photomosaic and with its reproduction in 2 different ways. This includes:

1. The assembly of a photomosaic,
2. To control the scale of the photomosaic,
3. The preparation for reproduction in a repro-camera and vacuum frame,
4. The ozalid copying (not printing!) process,
5. Offset printing demonstration,
6. (Lab 7) The use of the mosaic for flight planning and toward the design and location of a highway and as a preparation for a large scale topographic mapping project (Lab 8).

Note: The student ought to know the differences between:

- a - uncontrolled mosaic
- b - semi-controlled mosaic
- c - fully-controlled mosaic
- d - orthophoto mosaic

a-, b-, and c- can be made into map substitutes through cartographic enhancement (grid, names, certain lines, buildings, etc. delineated, symbols added). In spite of the cartographic enhancement these mosaics remain map substitutes since the photographs used are neither free of height displacement nor are they rectified - contrary to orthophotos. An orthophoto mosaic becomes a orthophoto map or a "photomap" through cartographic enhancement.

During this exercise we prepare an "uncontrolled" mosaic and transform it into one that is "Semi-controlled". This is done by determining an "average" scale for the uncontrolled mosaic and by comparing distances between identifiable points with identical points on a map (e.g. NTS 1:50,000, 1:25,000 or LRIS 1:4,800 (1" = 400')). Compare this with Figs. 1 and 2.

Time available: 1 Lab Period (Mosaic Assembly & Halfhour Photography)  
1 Lab Offset Printing

Fig. 1

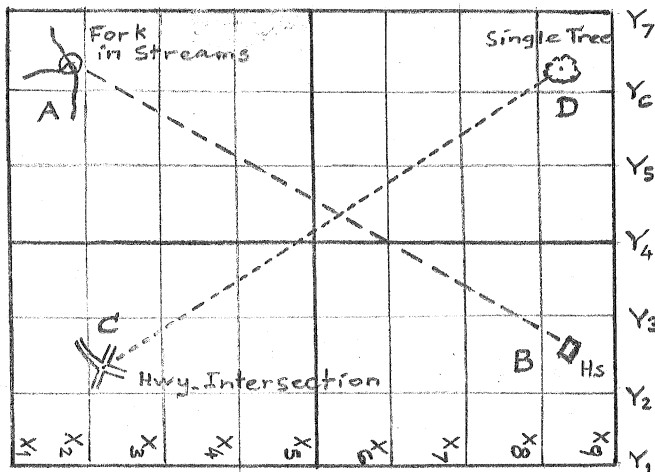

1:50 000 Map, UTM Grid  
 1:25 000 Map, UTM Grid  
 1:4 800 LRIS Maps, Stereographic  
 Grid (Plane x, y coords)

Fig. 2

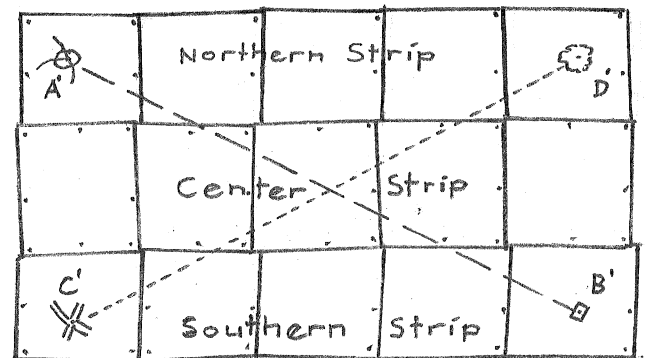

Uncontrolled Mosaic at  
 Photoscale

Scale Distances  $\overline{A'B'}$  and  $\overline{C'D'}$ .  
 Determine "mean scale"  
 (For scale determination see  
 lecture notes).

Steps involved in exercise:

1. Assemble photographs on styrofoam sheet into a mosaic.
2. Identify 4 points A', B', C' and D' and scale distances  $\overline{A'B'}$  and  $\overline{C'D'}$ . These points must be identifiable on the mosaic and on a map.
3. Scale the xy coordinates of pts. A, B, C and D on an available map and determine distances  $\overline{AB}$  and  $\overline{CD}$ .
4. Determine the "scale" (average of  $\overline{AB}$  and  $\overline{CD}$ ) of the uncontrolled mosaic.
5. To photograph the mosaic to a required scale determine the camera percentage setting.
6. Attach a suitable "Title" in a corner of the photomosaic.
7. Halftone photograph the mosaic at the required percentage setting - obtain a negative i.e. a halftone negative.
8. Contact - print the negative on:
  - a - photographic film - obtain positive - used to make Ozalid print.
  - b - offset printing plate - used in offset press to make print.
9. Make Ozalid print.
10. Demonstration at UNB Graphic Services: Offset - plate production and printing.



Material required by each group:

1. One Styrofoam sheet, 2 ft. x 4 ft.,
2. One set of aerial photographs consisting of 3 strips:
 

Strip 1:	No. 76-518 - Photos 183-191	=	9 Photos
Strip 2:	No. 76-518 - Photos 38-47	=	10 Photos
Strip 3:	No. 76-517 - Photos 248-256	=	9 Photos

TOTAL      28 Photos.

Note!! After assembly and use of the mosaic give back to the instructor 28 undamaged photos in order of strip and photo No. Groups who fail to do so will be required to replace damaged or lost photos. (Photos can be obtained at Dept. of Nat. Resources, 5th Floor, Centennial Bldg., Fredericton; Price per print \$2.).

3. A set of pins (1/2 inch in length),
4. One sheet Agfa-Gevaert lithographic negative film (Rip - Copyline Projection Film - Clear), 61 x 76 cm (24" x 30"),
5. One sheet Agfa-Gevaert lithographic negative film (P1. pm Copyline Projection Film - Matt drafting surface - 61 x 76 cm),
6. One halftone screen, 133 lines/inch (worth \$600. - handle with greatest care; touch only at the edges),
7. Chemicals: Kodak Developer Parts A and B, Kodak Stop Bath, Kodak Fixer,
8. Ozalid Paper,
9. A set of 1" = 400' (1:4800) topographic maps.

Instruments required: (handle all instruments with the greatest care - let the lab instructor make camera settings and use of vacuum frame).

1. Reproduction camera, Robertson-Comet (overhead), Neg. Size 81 x 81 cm, Nikkor Repro Lens f = 600 mm, 8 Quartz Iodine Lamps @ 1000 W,
2. Vacuum Frame with point source light + rheostat,
3. Photographic darkroom + usual darkroom equipment,
4. Ozalid Copying Machine.

Photo-mosaic assembly:

1. Lay-out and pin onto the Styrofoam-sheet the central strip. Use only every 2nd photograph. Place pins - 2 will do temporarily - in such a way that the photos to the North and South can be slipped underneath those of the central strip. Make a "best-fit" between photos along the strip. Push pins in on a slight slant, not perpendicular.
2. Lay-out the southern strip - again only every other photo. Slide photos beneath those of central strip. Remember there is a 30% side-overlap. Make a "best fit" between photos along the strip as well as between those of the adjacent strip. This is not easy at all since mainly, tip and tilt effects are very pronounced, especially in the Mactaquac Dam area. Place pins in such a way that the center strip photos still can be rotated over small angular amounts if this should become necessary to make "best fits" with the northern strip.
3. Lay-out northern strip; proceed as under 2.
4. With all photos in place, that is "best fits" obtained, place more pins to hold photos flat against styrofoam base.

The overall scale control of the "uncontrolled" photo-mosaic

With the above photo-mosaic assembly you have produced an "uncontrolled" photo-mosaic by simply fitting photos together the best way they fit. The next step is to photograph the entire assembly in such a way as to obtain a certain desired average scale. In doing so we produce a "semi-controlled" mosaic from one that is "uncontrolled". How now can we obtain a desired scale, e.g. 1:40 000 as an average for the entire assembly?

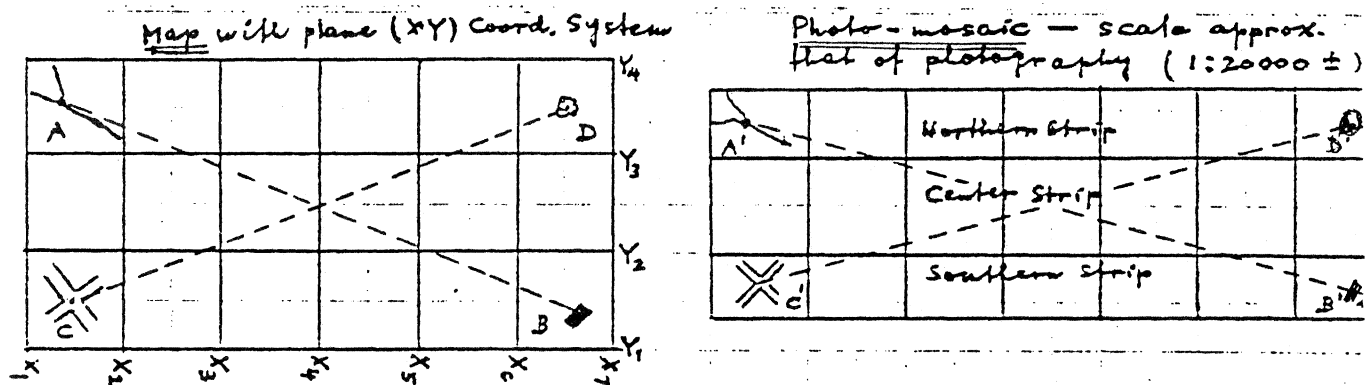

Pt. A = Fork in Stream; B = Bldg., C = Intersection of 2 Rds., D = Cluster of Trees

1. Select 4 "control points", one each in a corner of the mosaic. These 4 control points must be visible on both: the mosaic as well as on a map (maps). Scale the distances between diagonally opposite points A'B' and C'D' on the mosaic. Then scale the corresponding distances AB and CD on a map. Where several map sheets are involved the XY-coordinates of A, B, C and D must be scaled and distances AB and CD calculated.
2. Calculation of camera (percentage) setting for reduction (< 100%) or enlargement (> 100%). Knowing length AB and CD (scaled from map) we now can either:
  - a - calculate the average scale of the assembly, then the camera percentage setting can be computed or
  - b - instead of using the average scale we compute the camera percentage setting with the help of scaled distances.

Example (see your hand-out sheets on Map Scales):

Map scale  $S_M = 1:25000$  ( $S_M = 25\ 000$ ),  $1\ \text{mm} = 25\ \text{m}$

AB (scaled) = 630 mm  $\therefore DN_{AB} = 15\ 750\ \text{m}$

CD (scaled) = 650 mm  $\therefore DN_{CD} = 16\ 250\ \text{m}$

On photo-mosaic these distances were measured as being:

$A'B' = 281\ \text{mm}$ ,  $C'D' = 806\ \text{mm}$

Therefore scale  $S_{M_{A'B'}} = \frac{15\ 750\ \text{m}}{0.781\ \text{m}} = 20\ 166.45$  ( $S_M^* = 1:20\ 166.45$ )

Therefore scale  $S_{M_{C'D'}} = \frac{16250\ \text{m}}{0.806\ \text{m}} = \frac{20\ 161.29}{40\ 327.74 \div 2} = 20\ 161.29$  ( $S_M = 1:20\ 161.29$ )

Average Scale = 20 163.87  
for Photo-Mosaic

Percentage Setting for Camera:

$$\begin{aligned} \text{Percentage No} &= \frac{\text{Intended Size}}{\text{Original Size}} \times 100 \quad \text{or} \\ &= \frac{\text{Intended} \left\{ \begin{array}{l} \text{Photo Mos. Scale} \\ \text{Map Scale} \end{array} \right.}{\text{Original} \left\{ \begin{array}{l} \text{Map Scale} \\ \text{Photo Mos. Scale} \end{array} \right.}} \times 100 \end{aligned}$$

Our intended mosaic is: 1:20000  
Our original mosaic scale is: 1:20 163.87

$$\% \text{ No.} = \frac{\frac{1}{20\ 000}}{\frac{1}{20\ 163.87}} \times 100 = \frac{20\ 163.87}{20\ 000} \times 100 = 1.00819 \times 100$$

% No = 100.82%

A+  
1:20000  
1 mm = 20

OR: Since  $DN_{AB} = 15\ 750\ \text{m}$  and  $DN_{CD} = 16\ 250\ \text{m}$  at 1:25 000, these distances would be 787.5 mm resp. 812.5 mm at 1:20 000. However, we have measured  $DM_{A'B'} = 781\ \text{mm}$  and  $DM_{C'D'} = 806\ \text{mm}$ :

therefore our percentage setting for the camera is

$$\begin{aligned} \% \text{ No} &= \frac{\text{Intended Size}}{\text{Original Size}} \times 100 \quad \% \text{ No}_{A'B'} = \frac{787.5}{781.0} \times 100 = \\ & \quad \% \text{ No}_{C'D'} = \frac{812.5}{806.0} \times 100 = \underline{\hspace{2cm}} \\ & \quad \Sigma = \hspace{10cm} \div 2 \\ & \quad \text{Av. \% No.} = \underline{\hspace{2cm}} \end{aligned}$$